

PARTS LIST

Steering wheel



Control unit



HSW switch



Cable reel cord (marked RXXX)
(May not be used)



Cable reel cord (marked CXXX: with ACC + LKAS)
(May not be used)



Cable reel cord
(marked AXXX: with ACC + LKAS and paddle shift)
(May not be used)



Cable reel



10A Fuse



Relay



2 Self-tapping screws, 4 x 12 mm



2 TORX bolts



Steering wheel bolt



Switch bracket



Body cover A
(May not be used)



Body cover B (with paddle shift)
(May not be used)



Information



Illustration of the Heated Steering Wheel in the Vehicle



QDN1909BA

TOOLS AND SUPPLIES REQUIRED

- Phillips screwdriver
- 10 mm Open end wrench
- 10 mm Hex wrench
- Ratchet
- T-30 TORX bit
- Torque wrench
- Steering wheel puller
- Shop towel
- Masking tape
- HDS/MVCI

The following tool is available through the Honda Tool and Equipment Program. On the iN, click on: Service > Service Bay > Tool and Equipment Program, then enter the number under "Search." Or, call 888-424-6857.

- Trim Tool Set (T/N SOJATP2014)
- Plastic Trim Tool (T/N SILTRIMTL10)

INSTALLATION

Customer Information: The information in this installation instruction is intended for use only by skilled technicians who have the proper tools, equipment, and training to correctly and safely add equipment to your vehicle. These procedures should not be attempted by “do-it-yourselfers.”

NOTE:

- Observe all safety notes and precautions in the Service Manual in addition to those in this Installation Instruction.
 - Be careful not to damage the vehicle.
 - After installing the steering wheel, you must line up the steering wheel spoke angle to the straight ahead position by adjusting the front toe.
1. Turn the steering wheel so the front wheels are in the straight-ahead position.
 2. Wrap a shop towel around the hood latch.

HOOD LATCH (Wrap with a shop towel.)

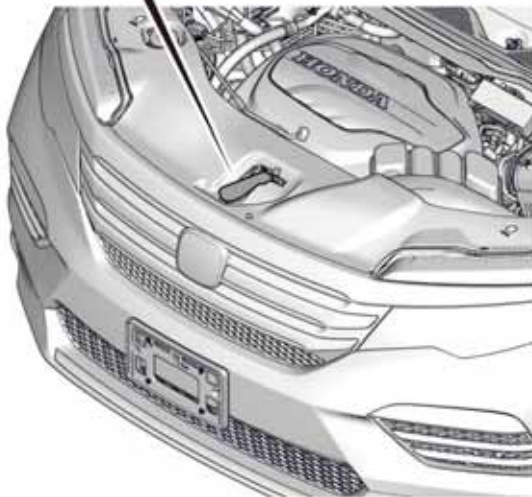
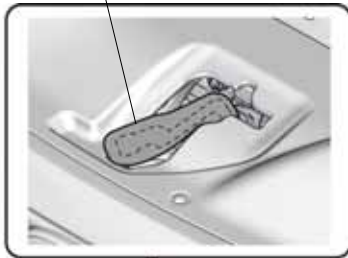

QDN1301AA

- Remove the front bulkhead cover.

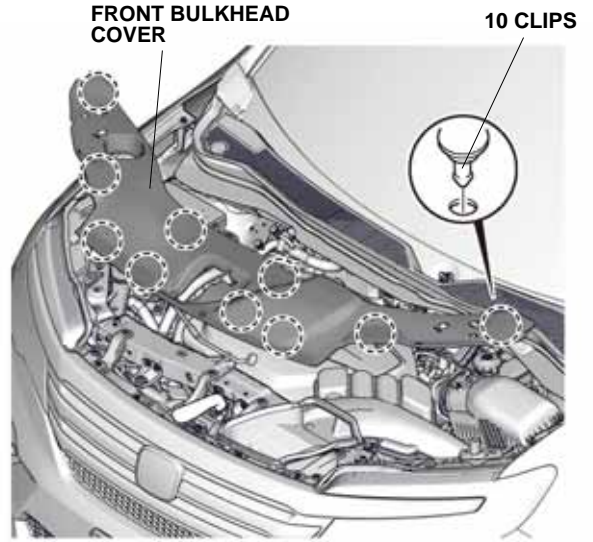

QDN1302AA

- Remove the intake air tube.
- Disconnect the negative cable from the battery, then wait at least 3 minutes before starting work.

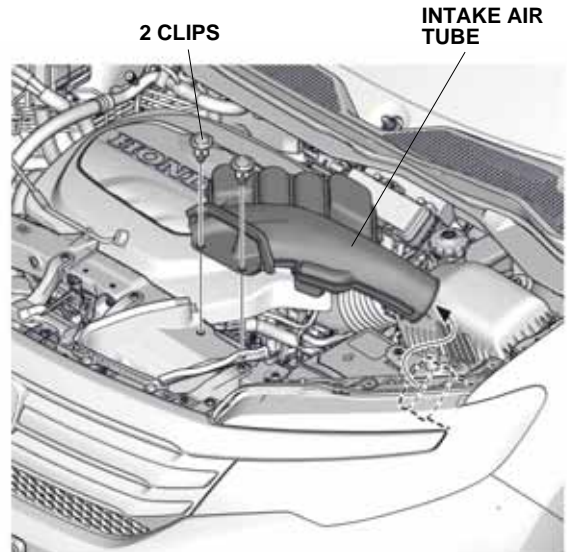

QDN1303AA

3. Pull away the door opening seal, and remove the driver's dashboard side lid.

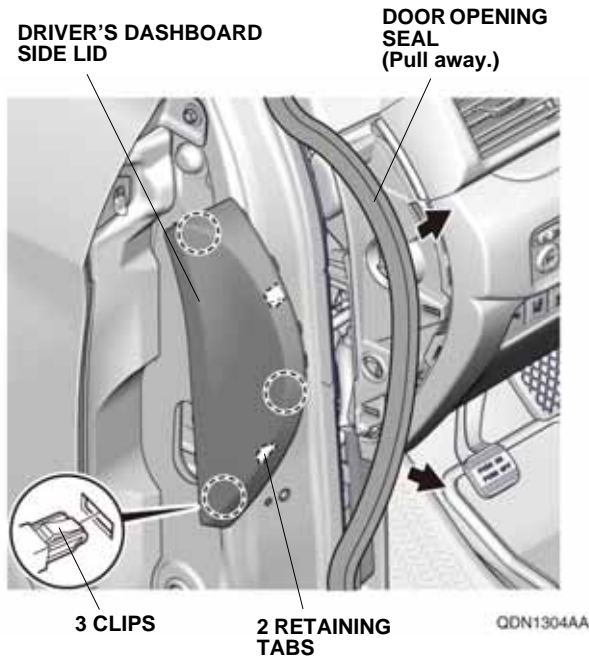

4. Remove the driver's dashboard under cover, unplug the vehicle connectors, and release the vehicle sensor.

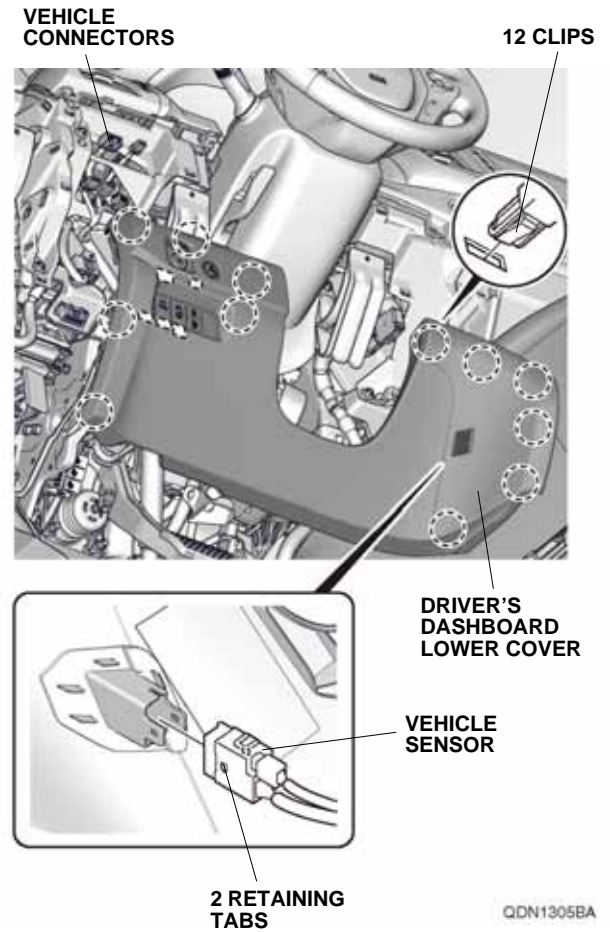

5. Lower the tilt lever, and remove the two TORX bolts.

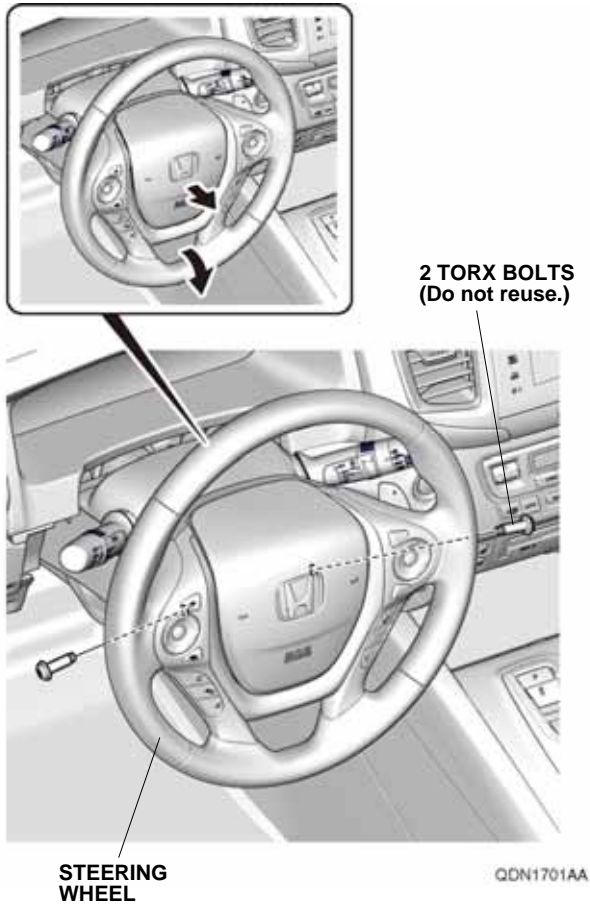

6. Unplug the two vehicle connectors and the vehicle connector.
NOTE: Be careful not to damage the connectors.

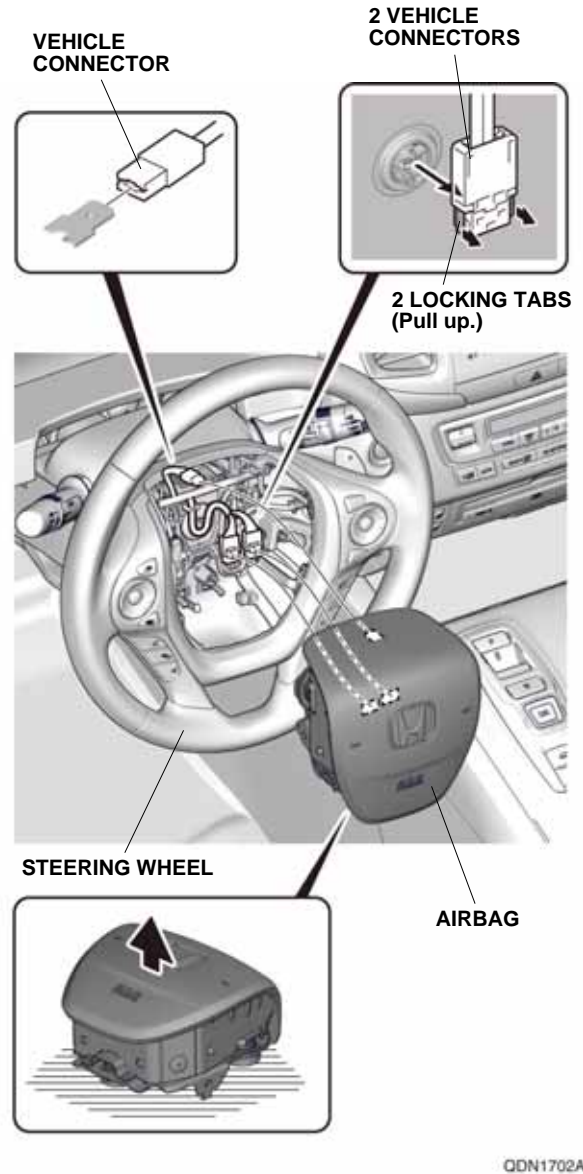

7. Remove the airbag. Do not drop the removed airbag or hit it on an object. Place the removed airbag in a safe place with the pad surface (top) facing upward.

- With the front wheels lined up in the straight forward position, unplug the vehicle connector from the cable reel, and loosen the steering wheel bolt.

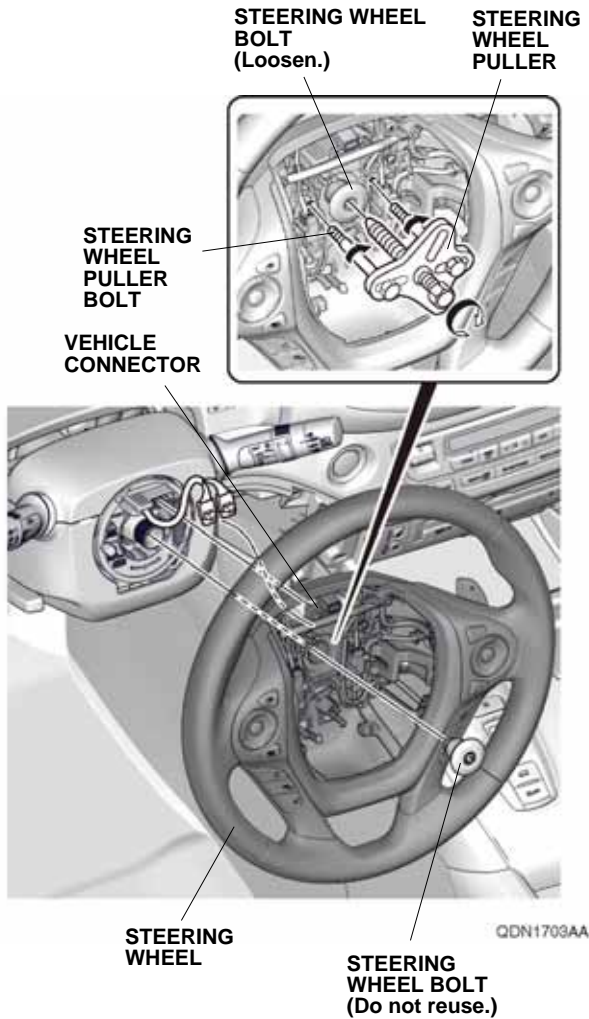

- Using a steering wheel puller, release the steering wheel. Do not thread the steering wheel puller bolts in more than 5 mm (0.20 in.). When removing the steering wheel, take care not to move the front wheels.
- Remove the steering wheel bolt, then remove the steering wheel.

- Attach the masking tape to the upper column cover as shown.

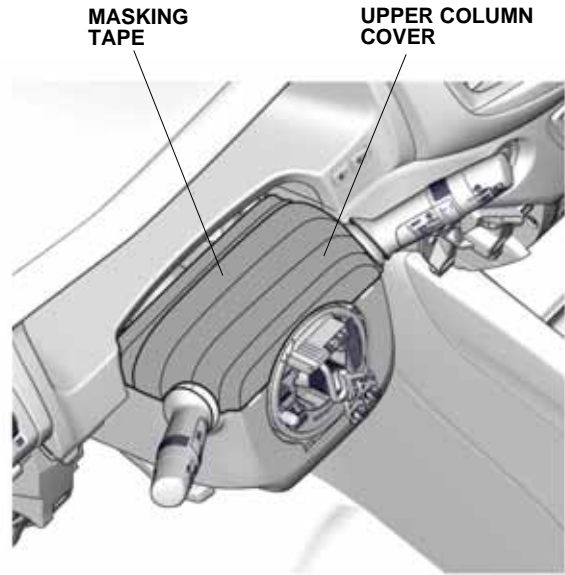

- Using a plastic trim tool, release the two retaining tabs.

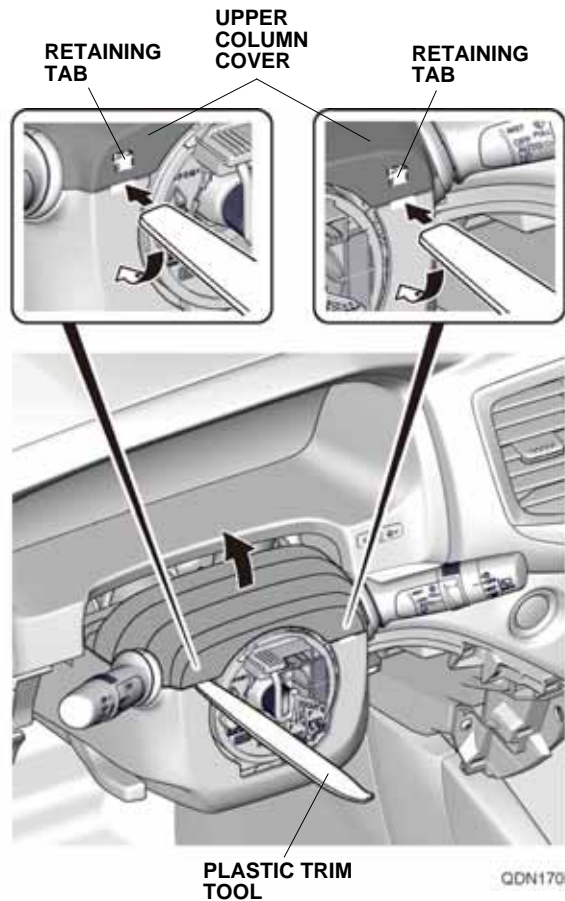

13. Release the upper column cover, and secure it to the dashboard with masking tape.

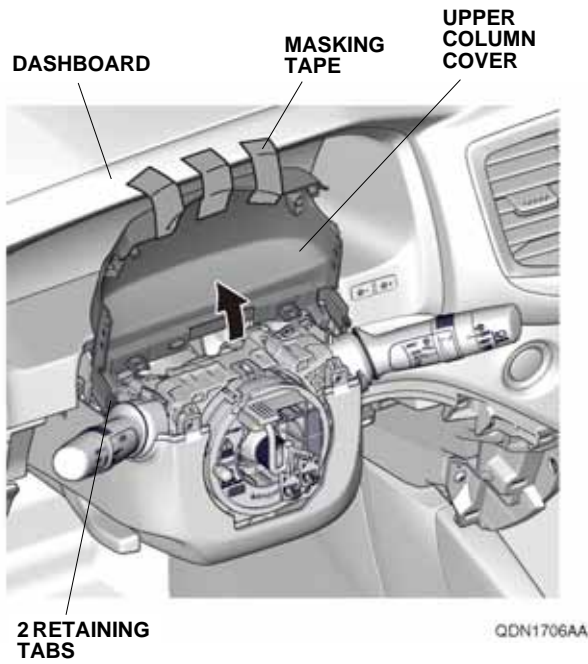

14. Remove two self-tapping screws from the lower column cover.

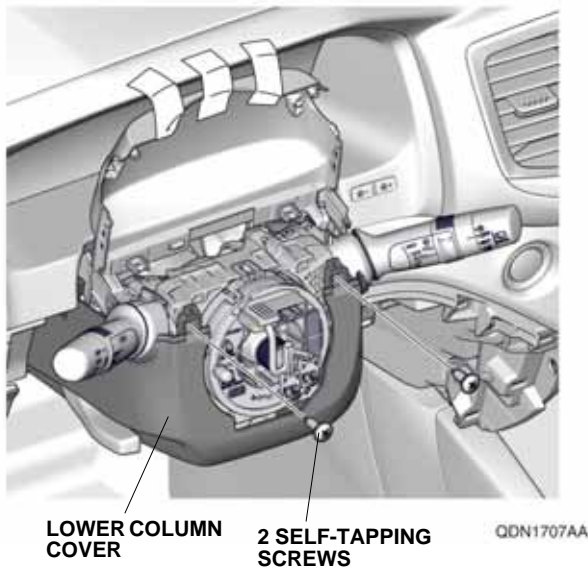

15. Remove the lower column cover.

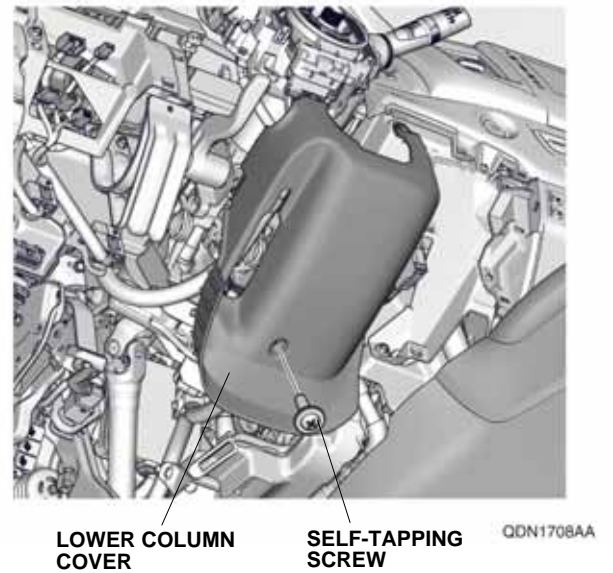

16. Unplug the vehicle connectors from the cable reel.

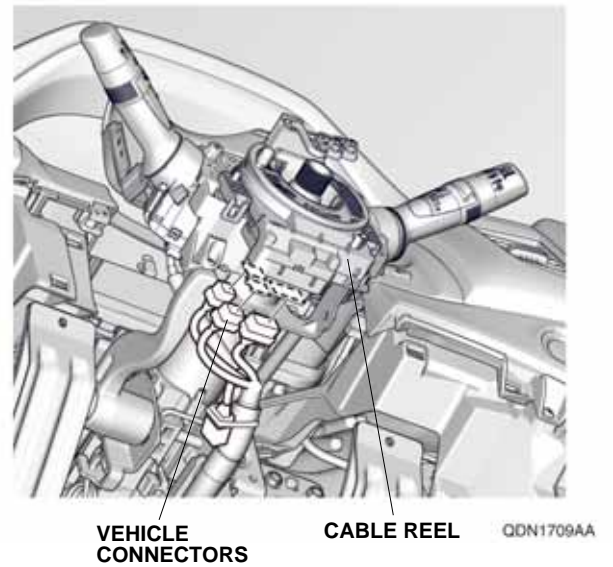

17. To prevent the cable reel from turning, attach masking tape to the cable reel. Remove the cable reel.

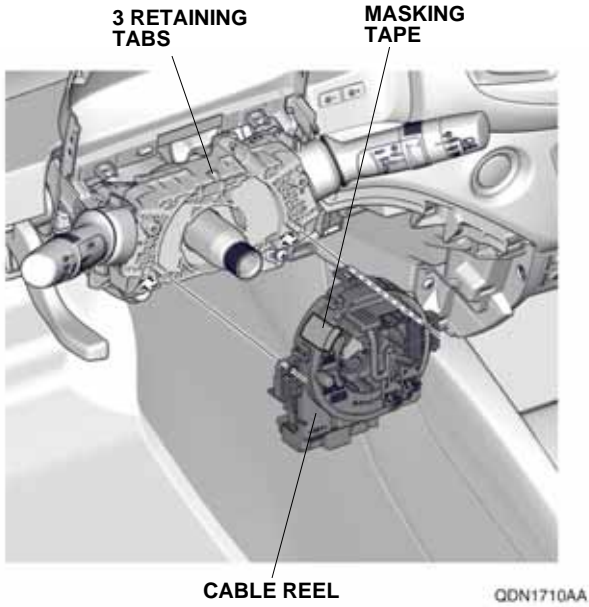

18. Remove the masking tape. Remove the steering angle sensor.

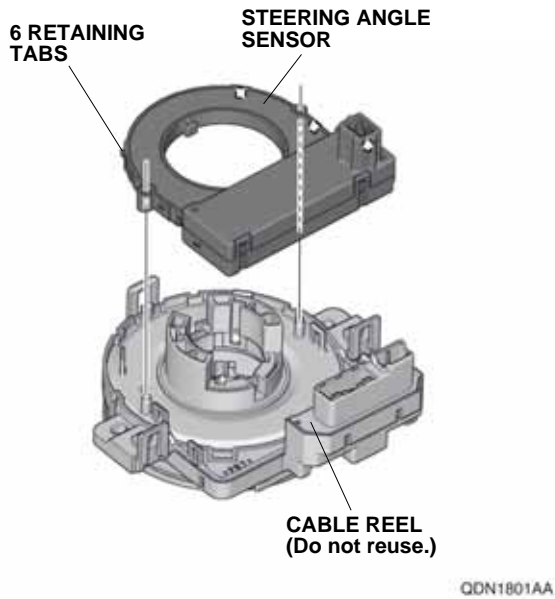

19. Install the steering angle sensor to the new cable reel with six retaining tabs.

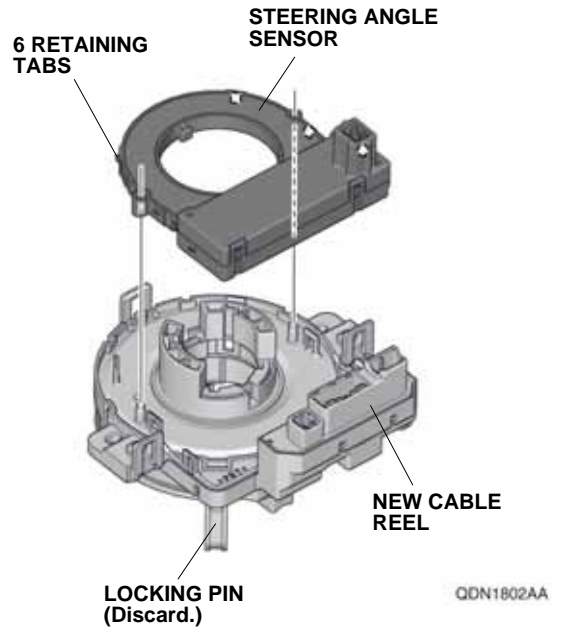

20. Remove the tape from the vehicle 2-pin connector, and remove the dummy connector from the vehicle 2-pin connector.

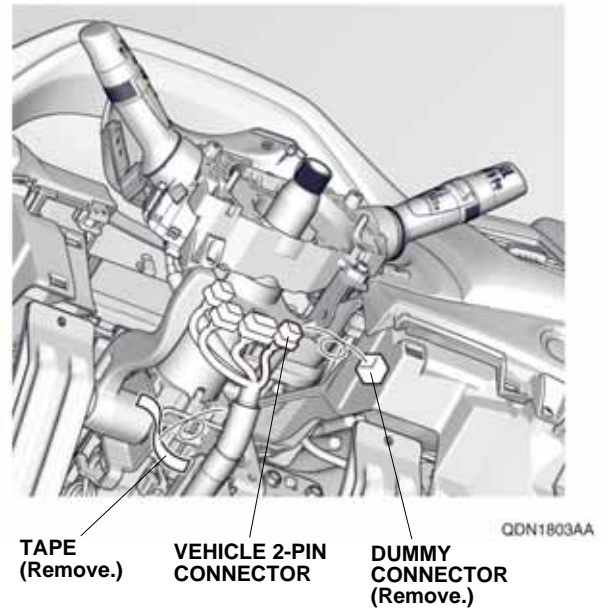

21. Install the new cable reel with three retaining tabs.

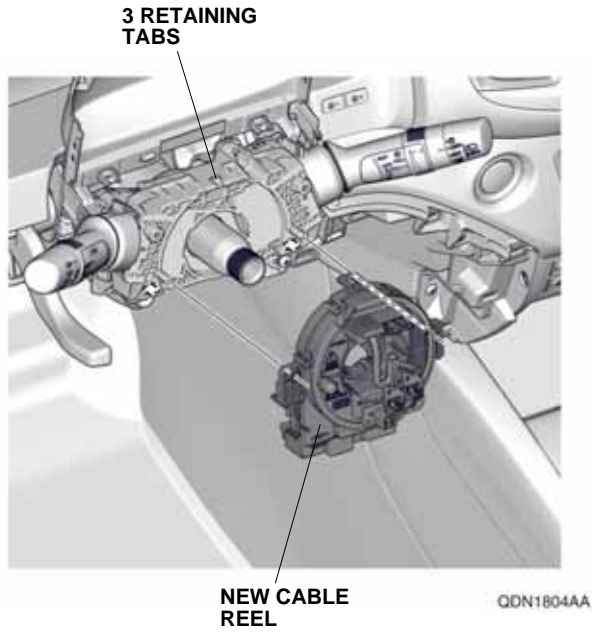

22. Plug the vehicle connectors into the new cable reel.

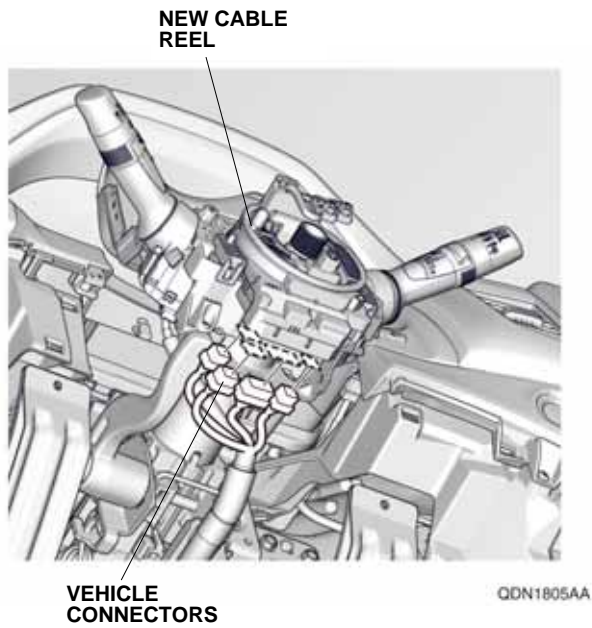

23. Remove the two washer-screws and two self-tapping screws.

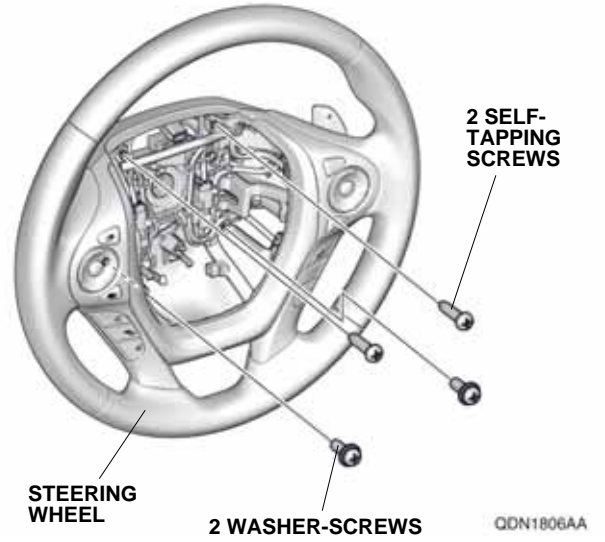

24. Remove the body cover.

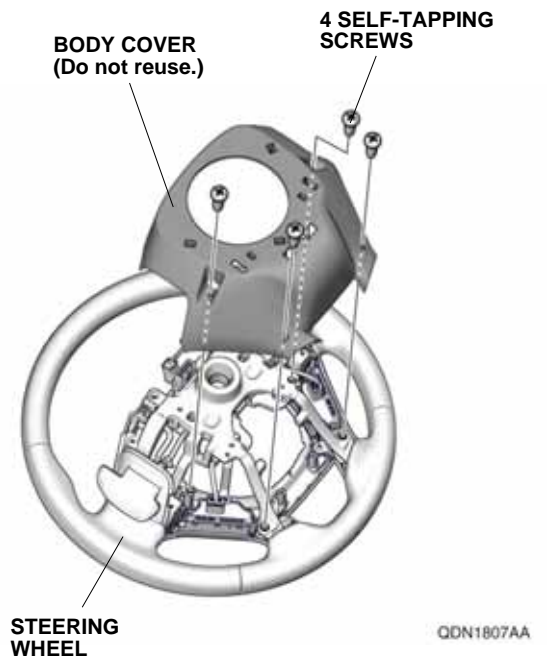

25. Remove the switch assembly, and unplug the vehicle connectors.

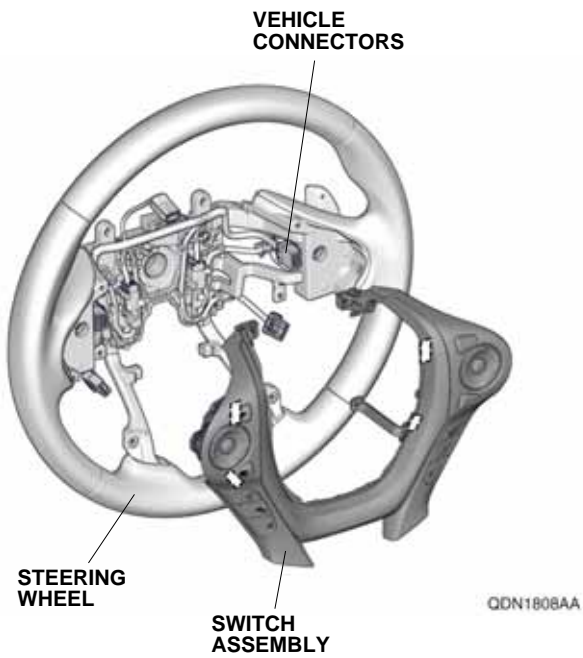

26. If equipped, remove the left and right paddle shifters and unplug the vehicle connectors.

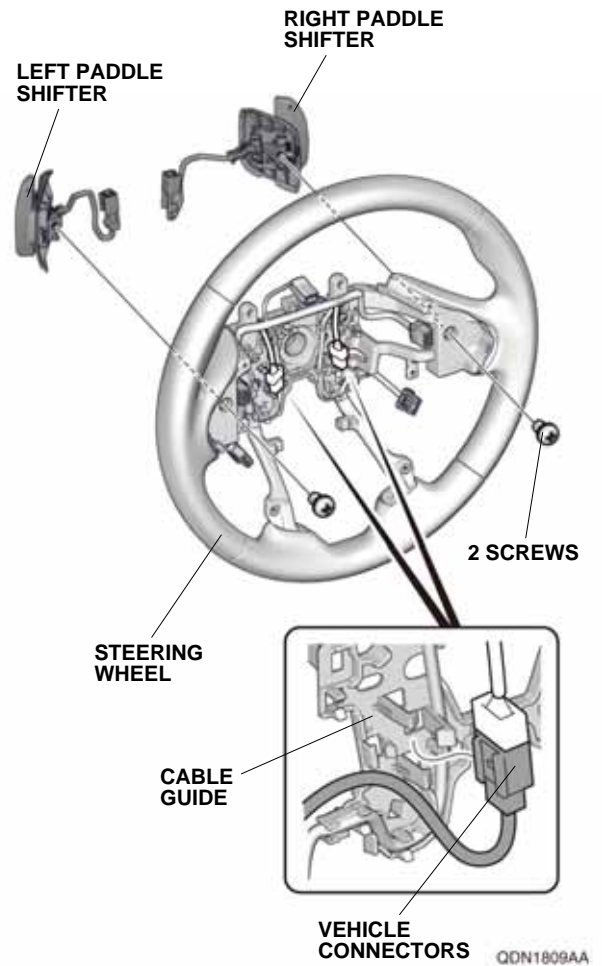

27. Remove the cable reel cord.

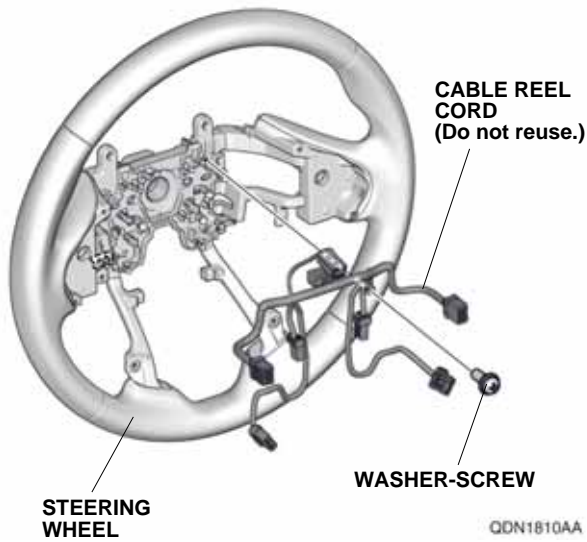

28. Remove the cable guide.

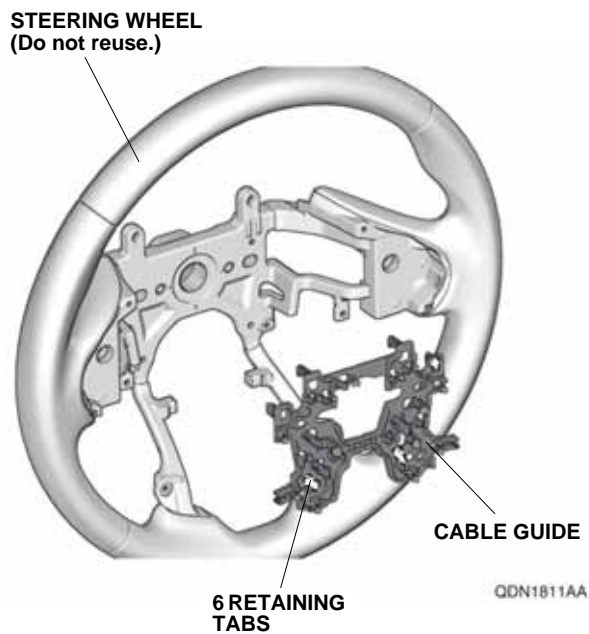

29. Install the cable guide on the new steering wheel with six retaining tabs.

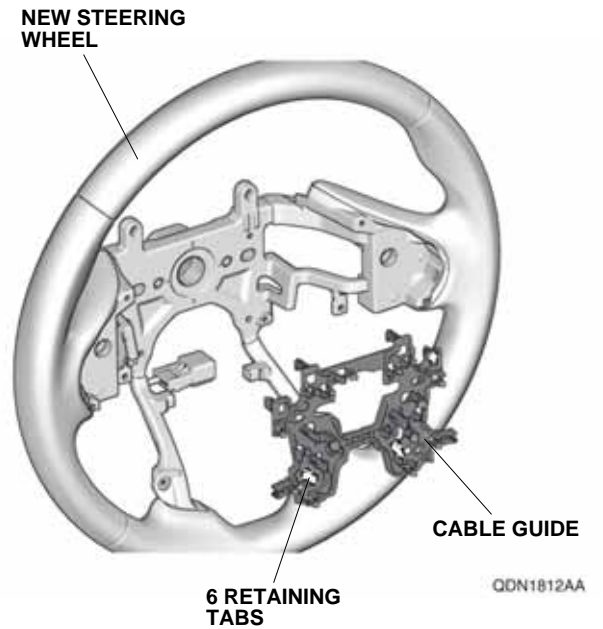

30. Install the new cable reel cord on the cable guide with one washer-screw. Plug the new cable reel cord 4-pin connector into the new steering wheel 4-pin connector, and secure the new cable reel cord to the cable guide.

With Paddle Shifter

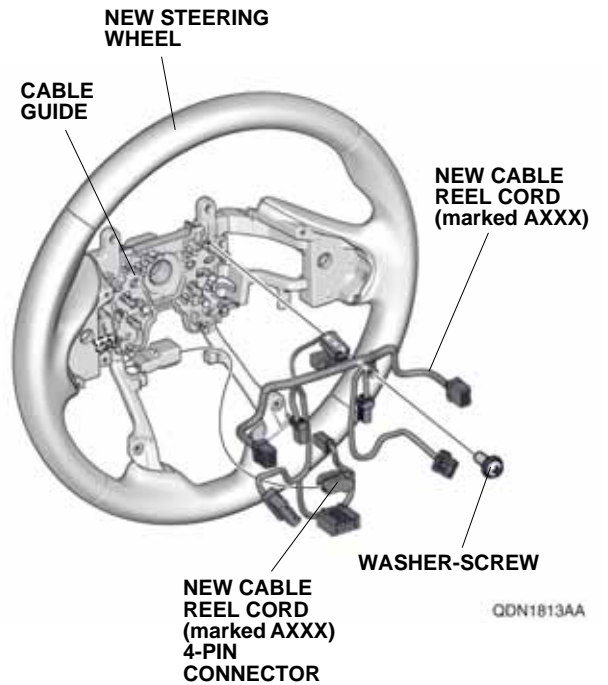

Without Paddle Shifter

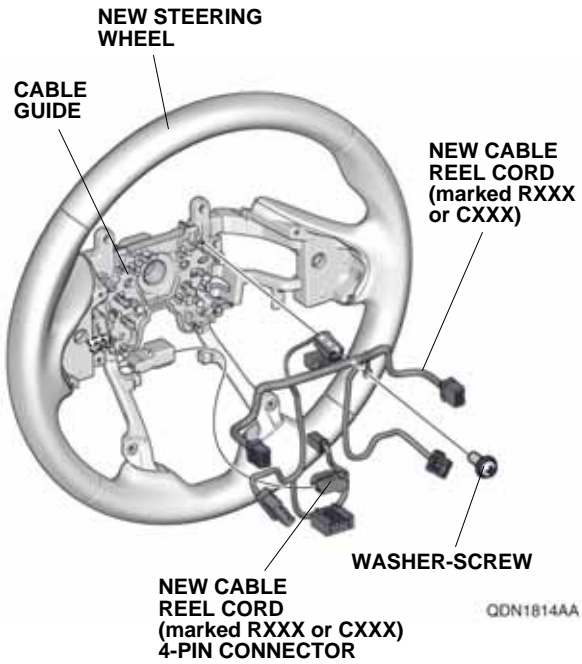

31. If equipped, install the left and right paddle shifters with two screws. Plug the new cable reel cord 4-pin connectors into the paddle shifter connectors, and secure the 4-pin connectors and paddle shifter cords on the cable guide.

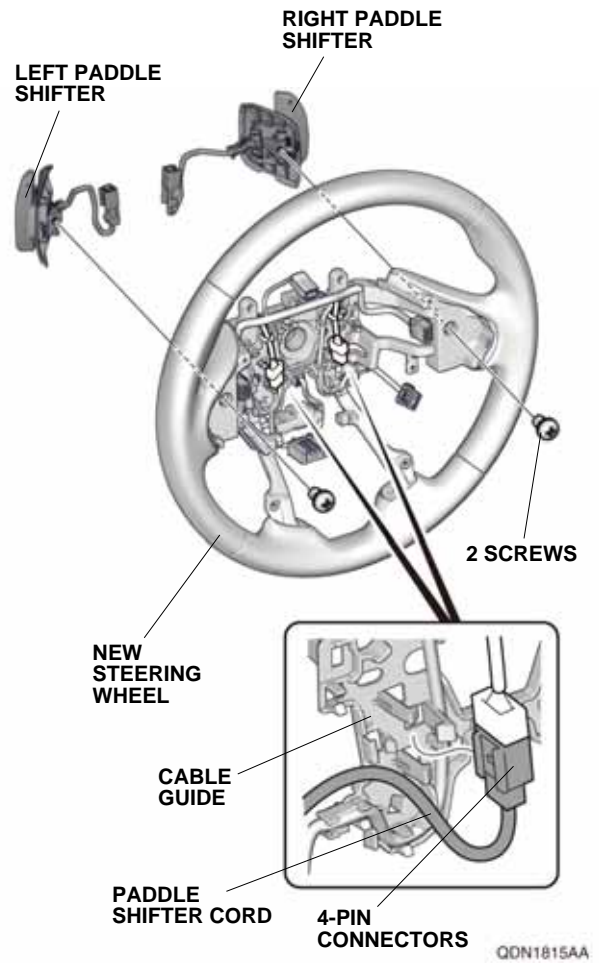

32. Remove the switch bracket and switch.

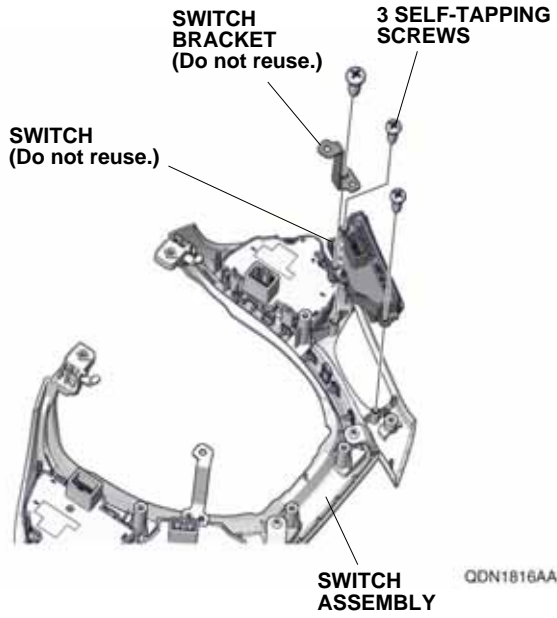

33. Install the new switch bracket and HSW switch on the switch assembly with three self-tapping screws.

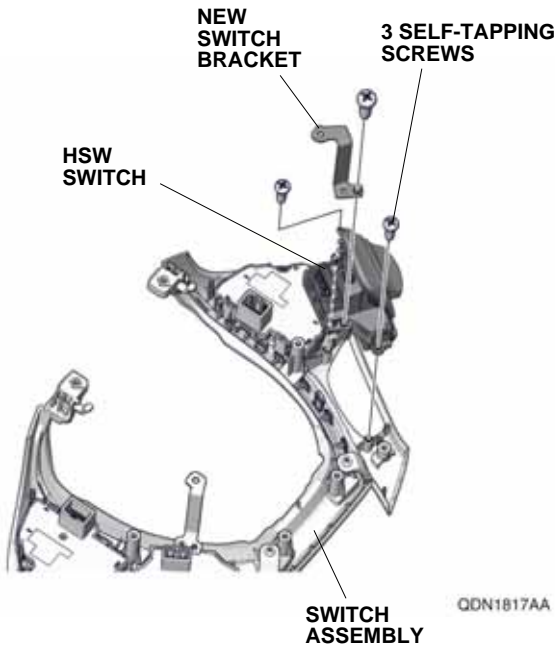

34. Install the control unit on the switch assembly with two 4 x 12 mm self-tapping screws.

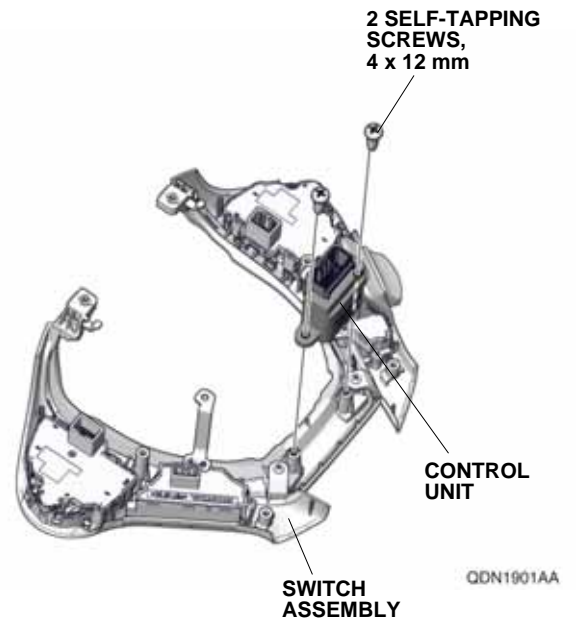

35. Plug the new cable reel cord connectors into the switch assembly, and install the switch assembly on the new steering wheel.

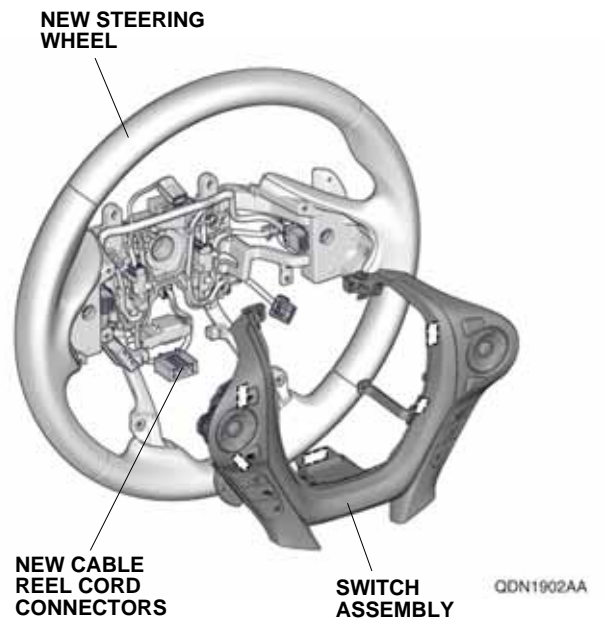

36. Install the new body cover on the new steering wheel with four self-tapping screws.

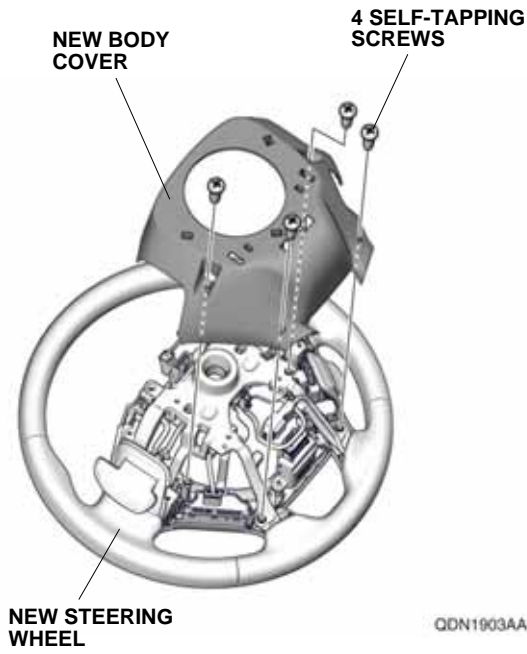

38. Install the two washer-screws and two self-tapping screws.

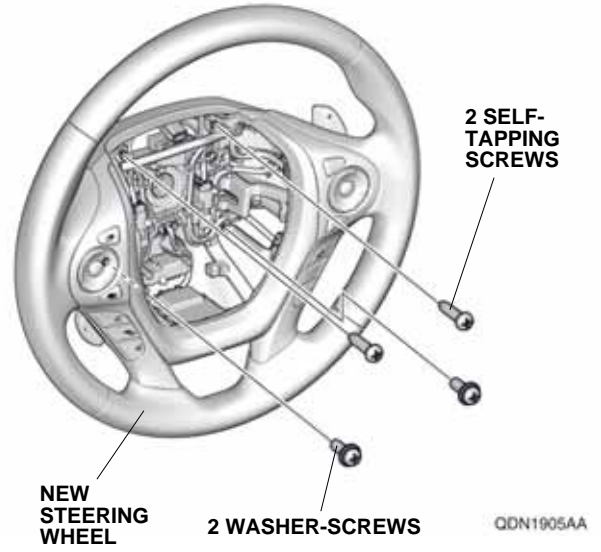

37. Secure the new cable reel cord and 4-pin connectors on the new body cover.

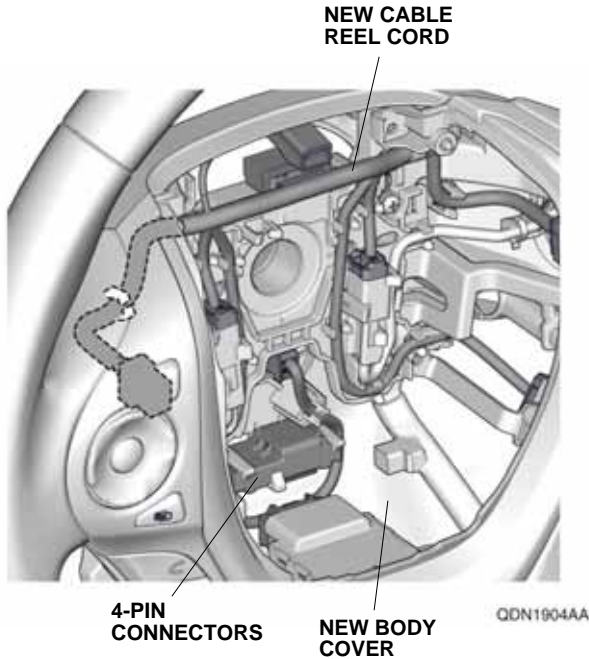

39. Install the lower column cover and upper column cover.

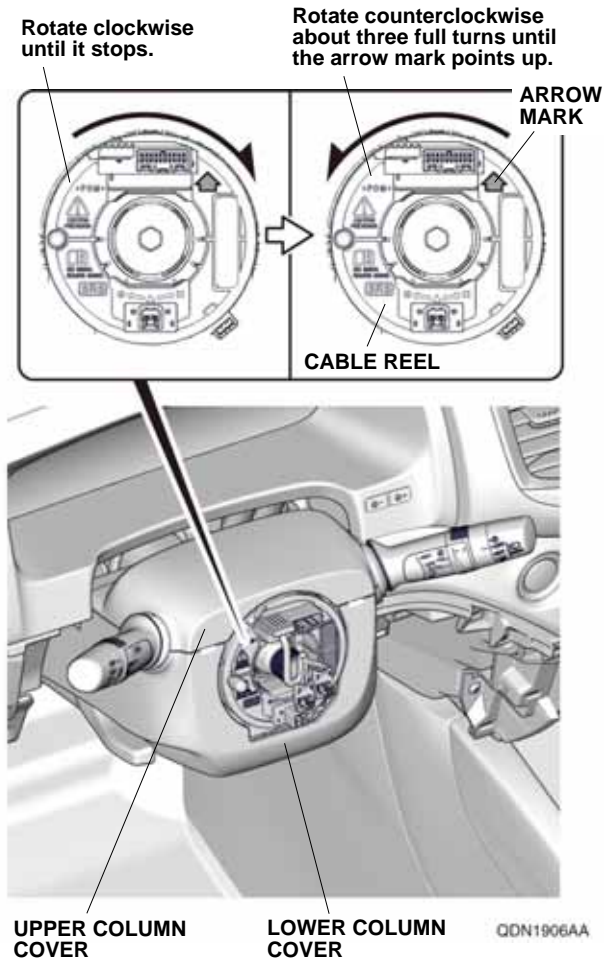

40. Before installing the steering wheel, make sure the front wheels are pointing straight ahead, then center the cable reel. Do this by first rotating the cable reel clockwise until it stops, then rotate it counterclockwise about three full turns. The arrow mark on the cable reel label should point straight up.

41. Install the new steering wheel to the steering column shaft in the straight-ahead position:

- Route the new cable reel 2-pin connectors cord through the opening in the new steering wheel. Route the new cable reel 2-pin connectors cord under the new cable reel cord, and secure it to the cable guide.
- Plug the new cable reel cord 20-pin and 2-pin connectors into the new cable reel.
- Check that the wire harnesses are not pinched.

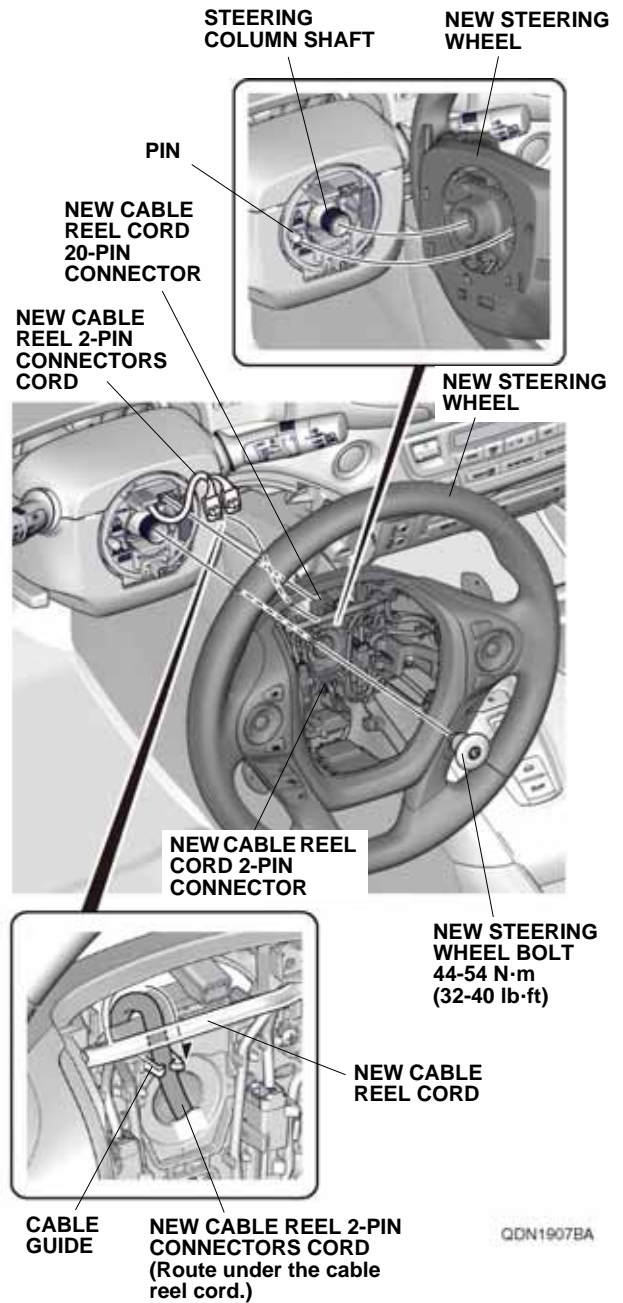

42. Install the new steering wheel bolt. Torque the steering wheel bolt to 44-54 N·m (32-40 lb·ft). Tighten at the specified torque within 5 minutes.
43. Install the airbag on the new steering wheel with two new TORX bolts (plug in the two new cable reel 2-pin connectors and the new cable reel cord 1-pin connector).
 - Alternately tighten the right and left TORX bolts so that the gaps on the right and left sides between the horn pad and the steering wheel are even. Torque the TORX bolts to 6.9-11.8 N·m (5.1-8.7 lb·ft).
 - TORX bolts are coated with non-hardening thread lock sealant, so they cannot be reused. When installing the steering wheel, be sure to replace the TORX bolts with the ones included in this kit.

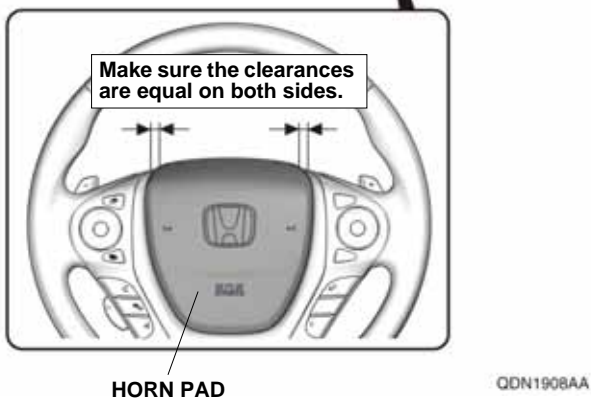
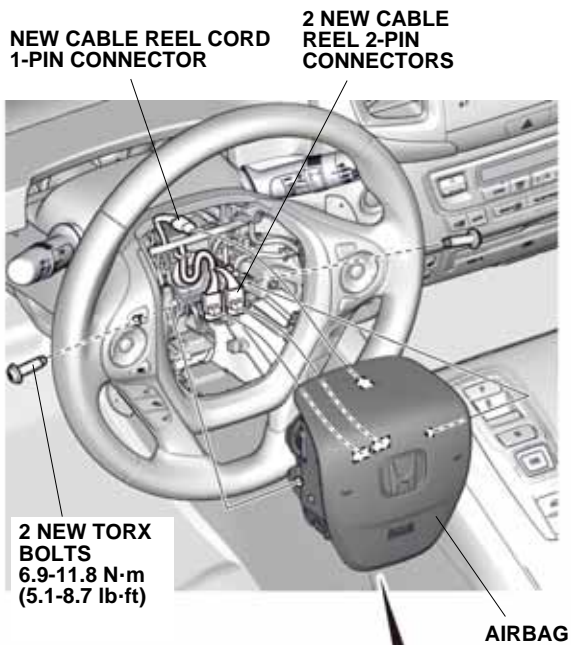

44. Install the relay on the vehicle harness located under the driver's dashboard under cover opening as shown.

NOTE: If a relay is already installed in the vehicle connector, go to step 45.

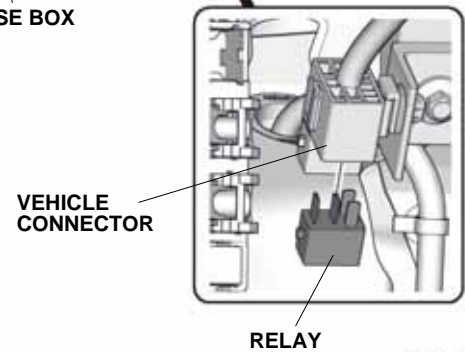
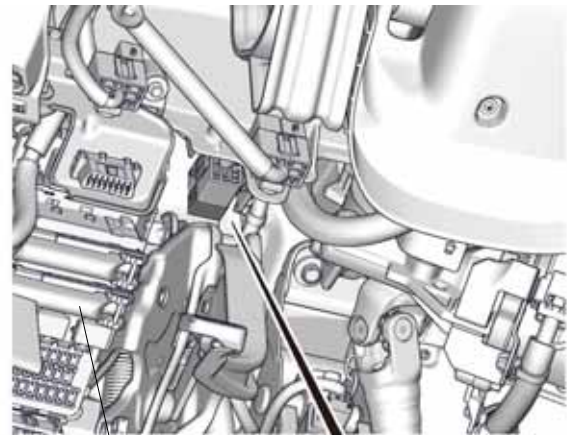

45. Install a 10 amp fuse in the #27 slot of the passenger side under hood fuse box.

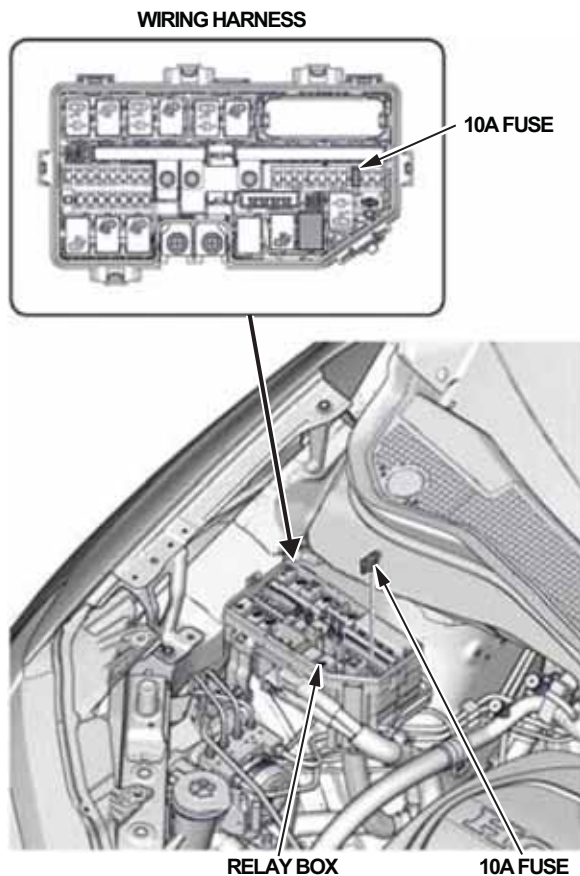

46. Check that all wire harnesses are routed properly and all connectors are plugged in.
47. Install all removed parts except for the front bulkhead cover and the intake air tube.
48. Connect the negative cable to the battery.
49. Install the front bulkhead cover and the intake air tube.
50. Connect the HDS/MVCI, and clear the DTCs.
51. Inspect the following items. If any abnormality is found, perform troubleshooting as described in the Service Manual of the vehicle.
- Press the ENGINE START/STOP BUTTON to the ON mode: the SRS indicator should come on for about 6 seconds and then go off.
 - Make sure the horn and steering wheel switches work properly.
52. Press and hold the audio unit power button for two seconds to restore the audio and navi (if equipped) system functions.
53. Set the clock on vehicles without navigation.
54. If necessary, restore the systems back to normal operation as described in the service information.

55. Make sure the steering wheel is in the straight-ahead position with the front wheels. If the spoke angle of the steering wheel is not in the straight-ahead position with the front wheels, adjust the front toe as described in the service information.
56. Do the VSA sensor neutral position memorization as described in the service information..