



INSTALLATION INSTRUCTIONS

Accessory
19" ALUMINUM WHEEL
 P/N 08W19-TVA-100
 P/N 08W19-TVA-100D

Application
2018 ACCORD

Publications No.
VERSION 1
 Issue Date
OCT 2017

PARTS LIST

Aluminum wheel
 (The illustration may differ from the actual wheel.)



Wheel center cap
 (The illustration may differ from the actual center cap.)



Valve



Wheel cleaning Information
 (This is contained in the kit of 08W19-TVA-100 only. Make sure your customer receives this information.)

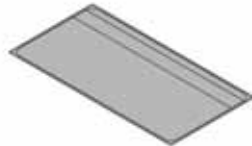

TPMS Information
 (This is for models not equipped with standard 19" wheels. Make sure your customer receives this information.)

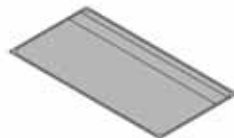

Tire pressure information label A
 (May not be used)

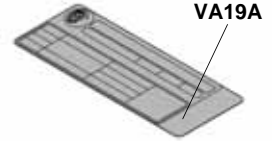

Tire pressure information label B
 (May not be used)

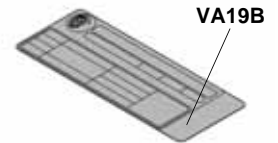

Supplemental information
 (For models not equipped with standard 19" wheels)



TOOLS AND SUPPLIES REQUIRED

Isopropyl alcohol
 Shop towel
 i-HDS

SPECIFICATIONS

Models equipped with standard 17" wheels:

Rim size	19 x 8 1/2J (inset 50)	
Tire size	245/35R19 93Y	
Bolt hole PCD	114.3 (5 holes)	
Tire pressure	Front	38 psi (260 kPa)
	Rear	38 psi (260 kPa)

Models equipped with standard 19" wheels:

Rim size	19 x 8 1/2J (inset 50)	
Tire size	235/40R19 96V	
Bolt hole PCD	114.3 (5 holes)	
Tire pressure	Front	33 psi (225 kPa)
	Rear	33 psi (225 kPa)

INSTALLATION

Customer Information: The information in this installation instruction is intended for use only by skilled technicians who have the proper tools, equipment, and training to correctly and safely add equipment to your vehicle. These procedures should not be attempted by "do-it-yourselfers."

NOTE:

- The illustrations of the aluminum wheels are shown for reference purposes only.
- Install the correct size tire.
- Use a tire changer to install and remove the tires as described in the operation manual furnished with the tire changer. Do not use a tire lever to install and remove the tires as it may cause damage to the tire and aluminum wheel.
- The wheel nut torque is 80 lb·ft (108 N·m).
- This kit should be installed only if the ambient air temperature is 60°F (15°C) or above.
- To allow the tire and loading information label adhesive to cure, do not wash the vehicle for 24 hours. Make sure your customer is aware of this.

Models equipped with standard 19" wheels:

Discard the TPMS information, tire pressure information label, and supplemental information in this kit.

- If the kit includes wheel cleaning information make sure your customer receives it.

Perform steps 1 through 17 for models not equipped with standard 19" wheels.

1. Open the driver's door. Using isopropyl alcohol on a shop towel, thoroughly clean the area where the tire pressure information label will attach. Remove the adhesive backing from the tire pressure information label, and attach it over the standard tire pressure information label as shown.
NOTE: Confirm the spare tire size, and appropriate label.

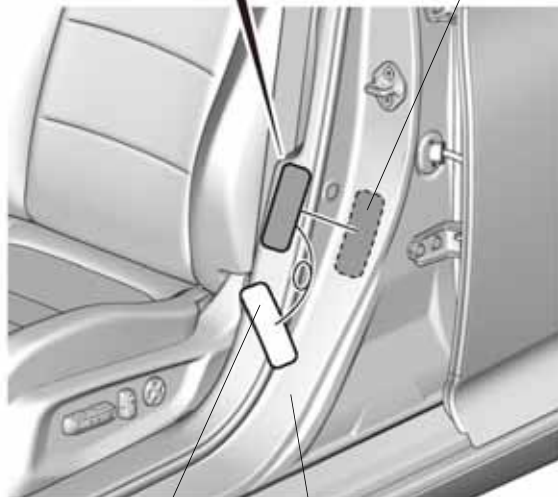
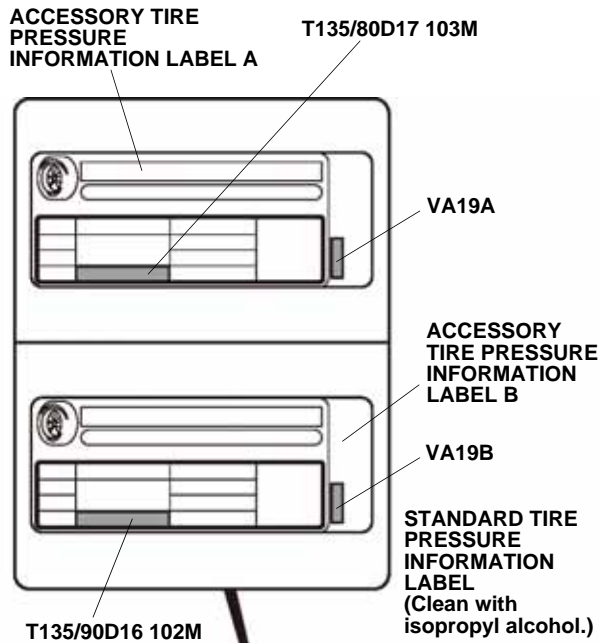

2. Attach the Supplemental Information page included in this kit into the Owner's Guide as described on the Important Information to Dealer page.

Inch-up Tire Pressure Programming

NOTE: Make sure you are using the latest i-HDS version as described on SIS.

3. Connect the i-HDS to the data link connector, then turn the ignition to ON.

Select **Connect to the Vehicle.**

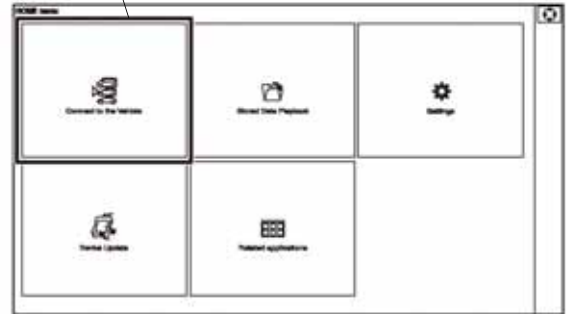

QF40602AN

4. Start the Diagnostic System, select **Connect to the Vehicle.**
5. Select **System Selection Menu.**

Select **System Selection Menu.**

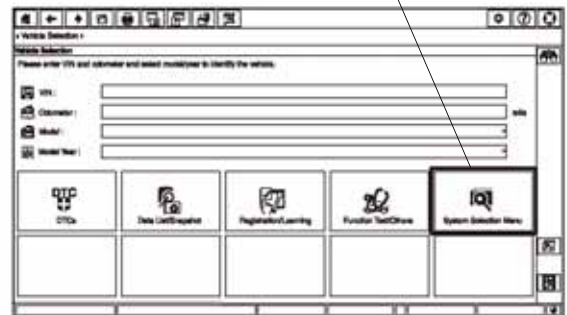

QF40603BN

6. Select **ABS/VSA**, and click the check button.

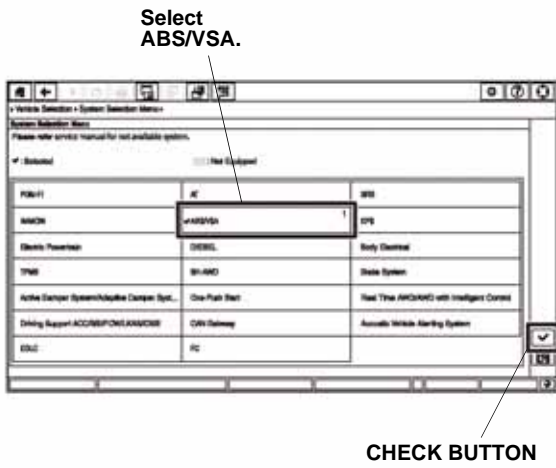

QF40604BN

8. Select **YES**.

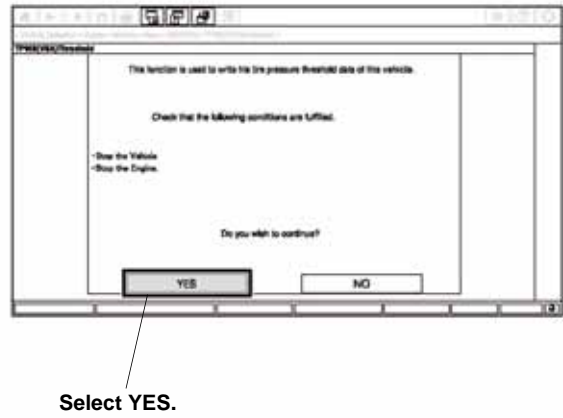

QF40606BN

7. Select **TPMS (VSA) threshold**, and click the check button.

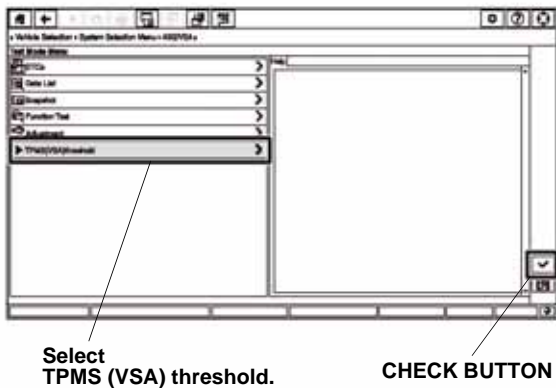

QF40605BN

9. Select **YES**.

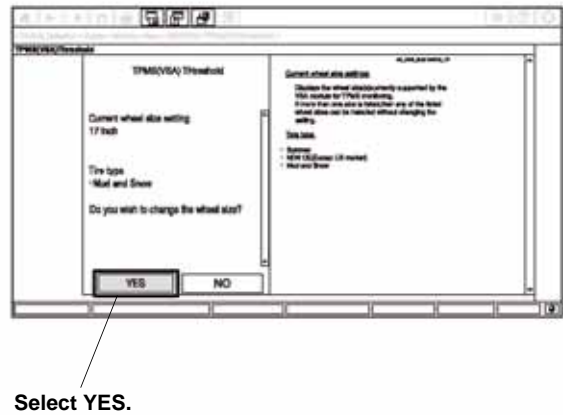

QG21404AN

10. Select **19 inch**, and click the check button.

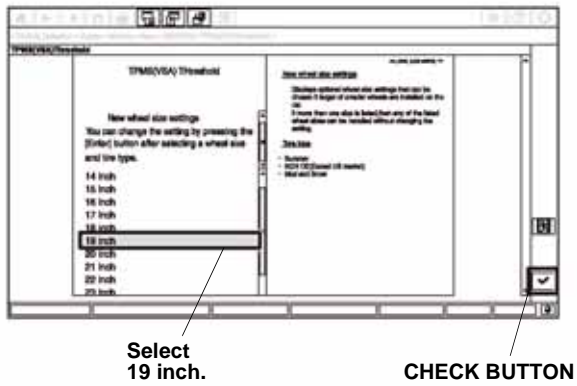

QF40608BN

11. Select **Mud and snow**, and click the check button.

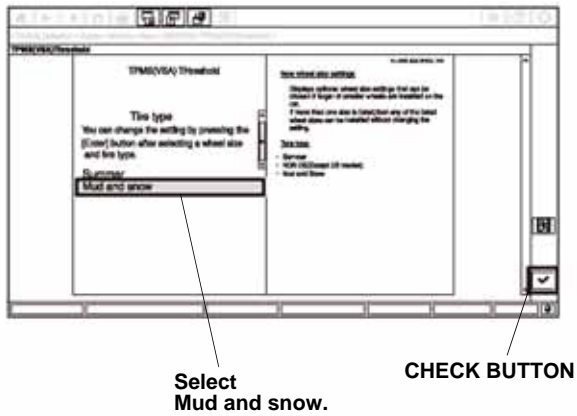

QF40609BN

12. When you see this message: **Turn the ignition switch off**. Turn the ignition to OFF.



QF40610BN

13. When you see this message: **Turn the ignition switch on**. Turn the ignition to ON.



QF40611BN

14. Click the check button.



CHECK BUTTON

QF40612BN

15. Disconnect the HDS from the data link connector.
16. Do the TPMS calibration according to the instructions in the service information (TPMS Calibration).
17. After finishing the work, write tire size, tire pressure, HDS version, dealer name, technician's signature, and date in "Service History Page for Honda Accessory Alloy Wheels" page included in this kit.
 - Make sure your customer understands the contents of the "Supplemental Information" when delivering the vehicle.
 - If the kit includes wheel cleaning information, make sure your customer receives this information.

Deflation Warning System Threshold Rewriting

- If the 17-inch wheels are to be installed back on the vehicle, you must change the threshold value with the HDS; refer to steps 3 to 16.
- For step 10, select the 17-inch.

NOTE: If 17-inch is displayed on the current wheel size settings, go to step 15.

- After finishing the work, write tire size, tire pressure, HDS version, dealer name, technician's signature, and date in "Service History Page for Honda Accessory Alloy Wheels" page.