

HONDA INSTALLATION INSTRUCTIONS

Accessory
FRONT SPLASH GUARDS
P/N 08P08-T6Z-100

Application
2017 RIDGELINE

Publications No.
VERSION 1
Issue Date
MAY 2016

PARTS LIST

Left front splash guard



Right front splash guard



4 Self-tapping screws, 5 x 20 mm



TOOLS AND SUPPLIES REQUIRED

Phillips screwdriver

Stubby Phillips screwdriver

Pushpin

Illustration of the Front Splash Guards on the Vehicle

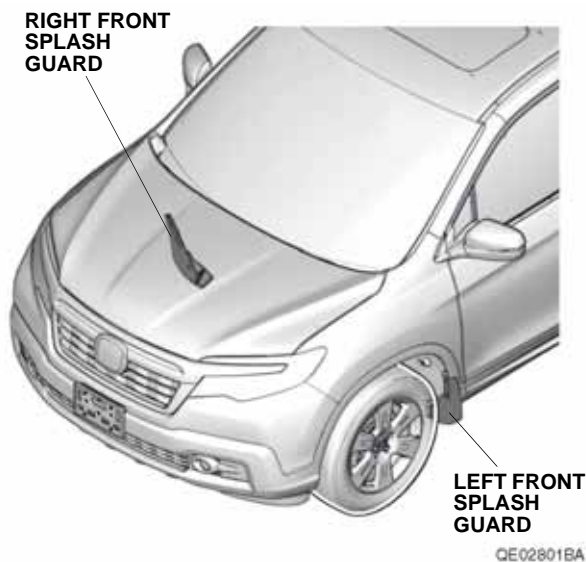

INSTALLATION

Customer Information: The information in this installation instruction is intended for use only by skilled technicians who have the proper tools, equipment, and training to correctly and safely add equipment to your vehicle. These procedures should not be attempted by “do-it-yourselfers.”

NOTE:

- Do not damage the body paint finish.
- Clean and wax the areas to be covered with a high-quality paste wax.

Installing the Front Splash Guards

1. Turn the steering wheel fully counterclockwise.

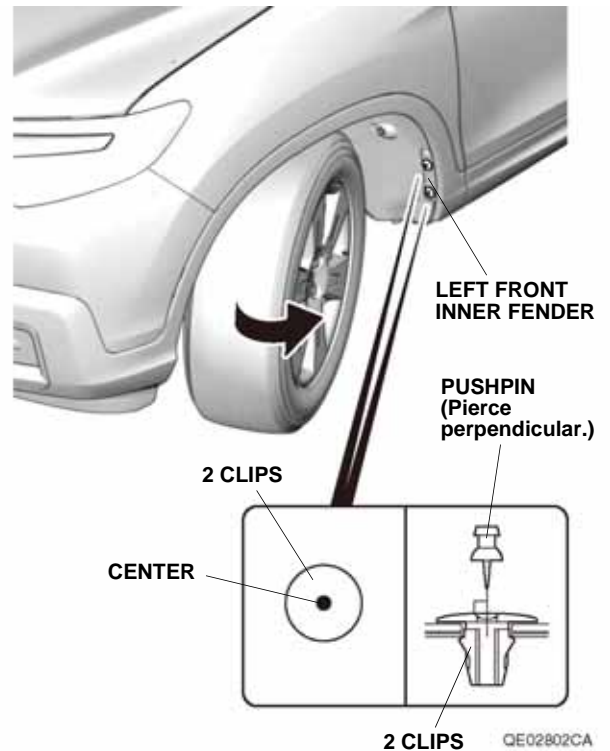

2. Using a pushpin, pierce the center of the top two clips on the left front inner fender.
NOTE: Make sure to pierce perpendicular to the left front inner fender.

3. Remove this self-tapping screw from the left front inner fender.

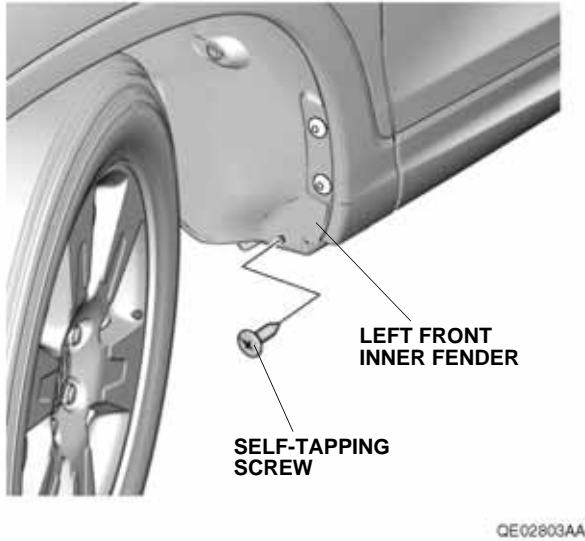

4. Loosely install the left front splash guard onto the left front inner fender with two 5 x 20 mm self-tapping screws and the self-tapping screw removed in step 3.

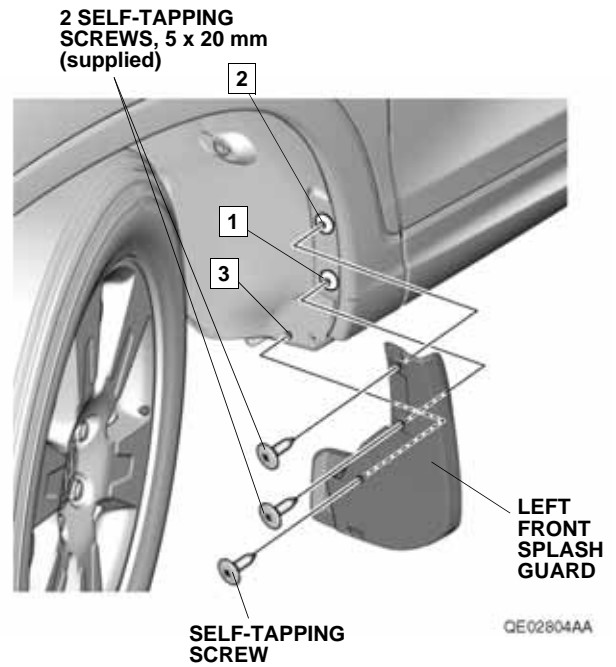

5. While holding the left front splash guard against the left front inner fender, tighten the self-tapping screws in the order shown.
NOTE: Make sure there is no gap between the left front splash guard and the vehicle body. If there is a gap, loosen the self-tapping screws, hold the splash guard against the body, and retighten the screws.
6. Turn the steering wheel fully clockwise, and repeat steps 2 through 5 to install the right front splash guard.