

PARTS LIST

Left fog light



Right fog light



Combination light switch



Fog light harness



Ground harness

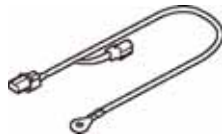

18 Wire ties



4 Wire ties with clip



2 Wire ties with holder



Relay

**TOOLS AND SUPPLIES REQUIRED**

Phillips screwdriver

Flat-tip screwdriver

Ratchet

10 mm Socket

10 mm Open end wrench

Diagonal cutters

Masking tape

Blanket

Shop towel

The following tool is available through the Honda Tool and Equipment Program. On the iN, click on: Service > Service Bay > Tool and Equipment Program, then enter the number under "Search." Or, call 888-424-6857.

• Trim Tool Set (T/N SOJATP2014)

• Plastic Trim Tool (T/N SILTRIMTL10)

Illustration of the Fog Lights in the Vehicle

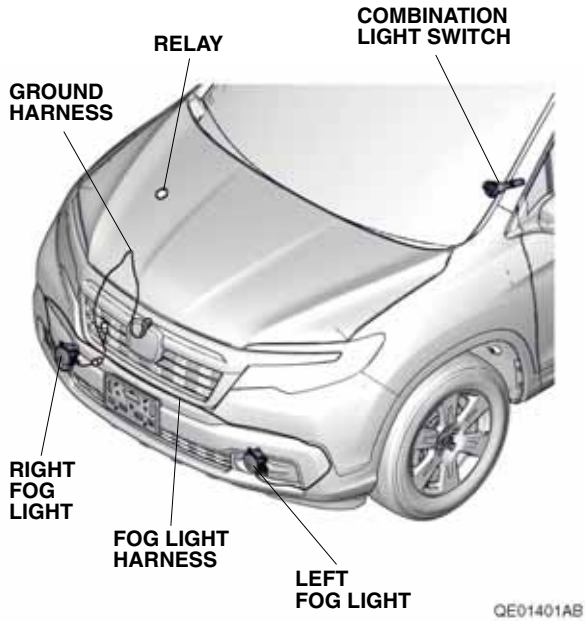

INSTALLATION

Customer Information: The information in this installation instruction is intended for use only by skilled technicians who have the proper tools, equipment, and training to correctly and safely add equipment to your vehicle. These procedures should not be attempted by “do-it-yourselfers.”

1. Disconnect the negative cable from the battery:
 - Wrap a shop towel around the hood latch.

HOOD LATCH
(Wrap with a shop towel.)

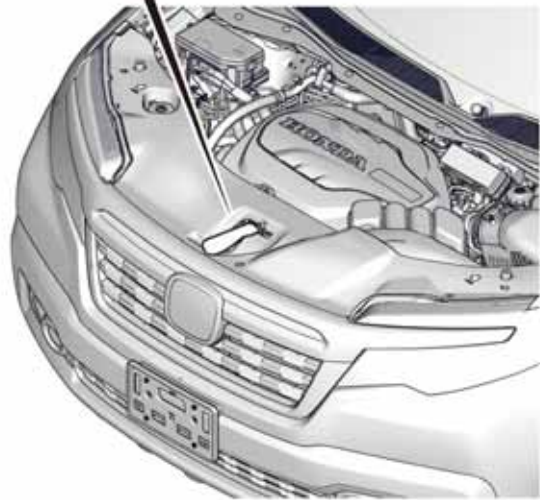
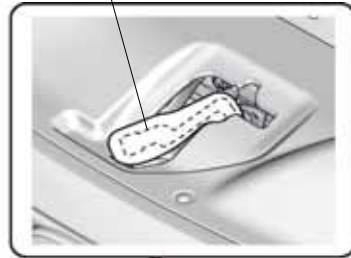

- Remove the front bulkhead cover.

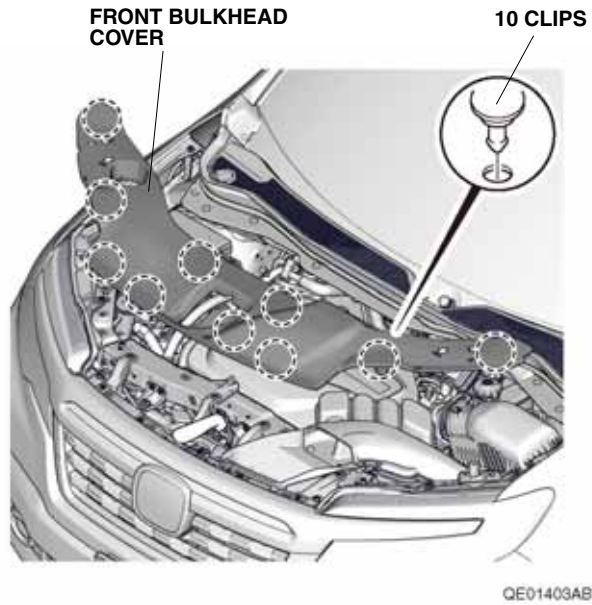

- Remove the intake air tube.
- Disconnect the negative cable from the battery.

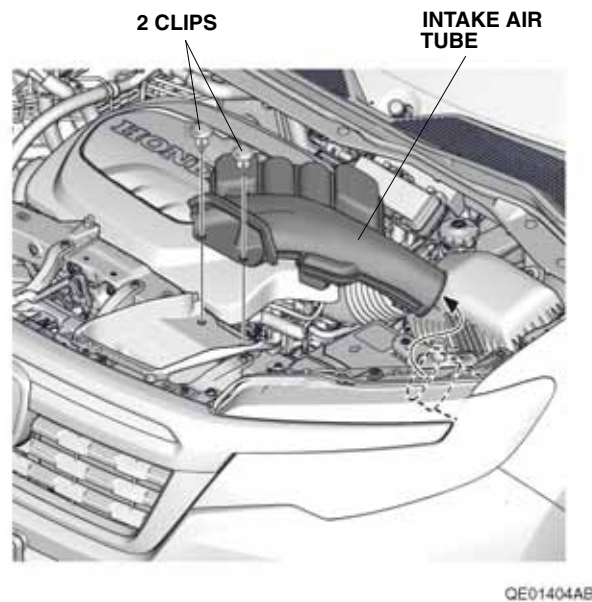

- Remove the three self-tapping screws from the left front wheel arch protector.

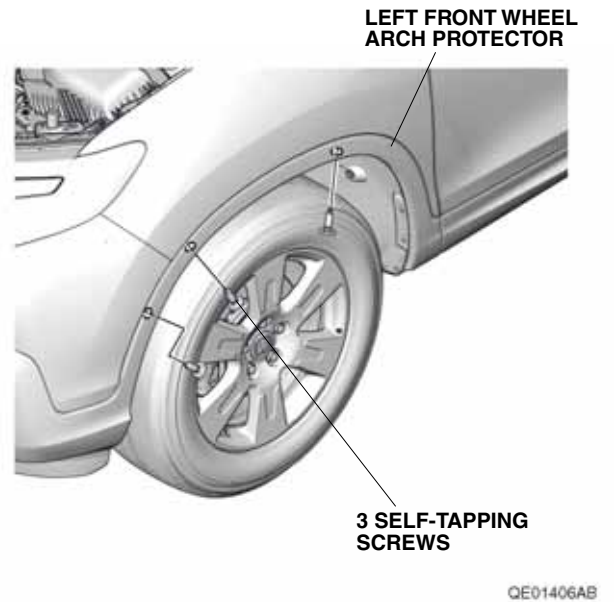

- Remove the left front wheel arch protector.

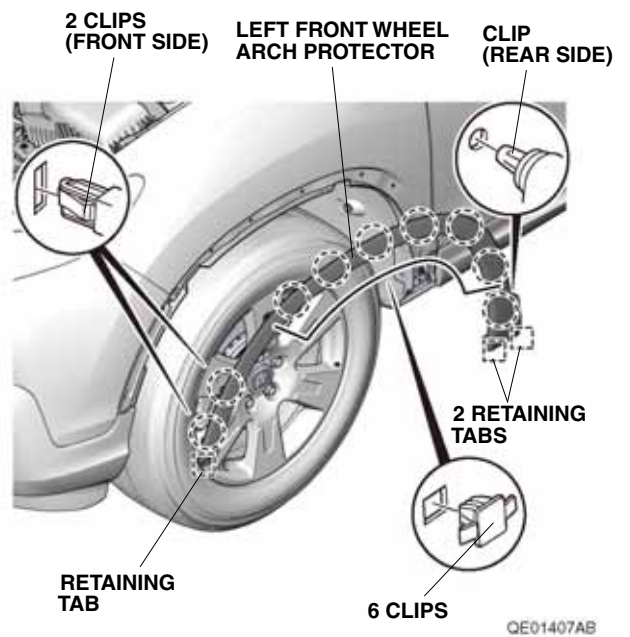

- Repeat steps 2 and 3 on the right side of the vehicle.

5. Remove the front bumper:
 - Using a flat-tip screwdriver, remove the H emblem from the front grille.

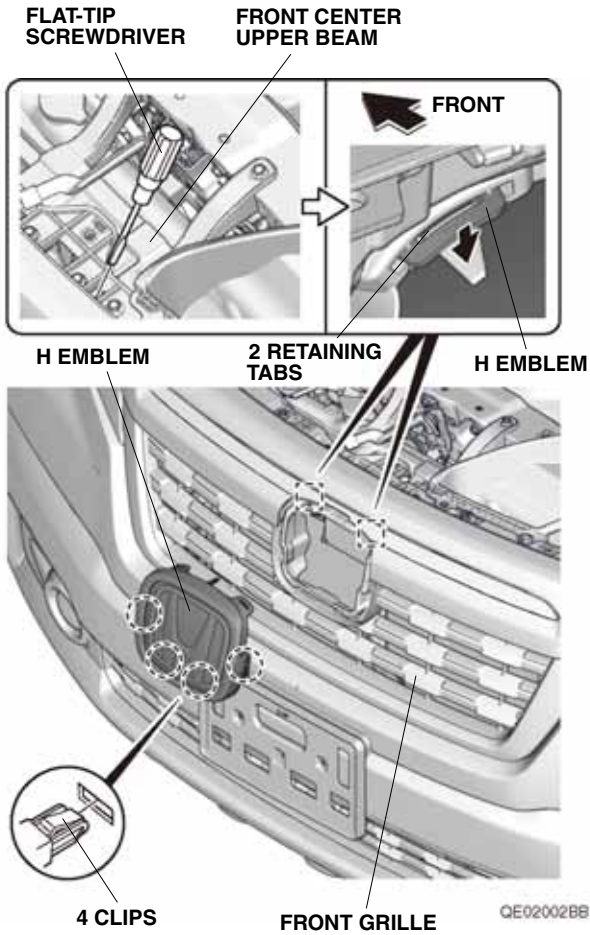

- Remove the front upper grille.

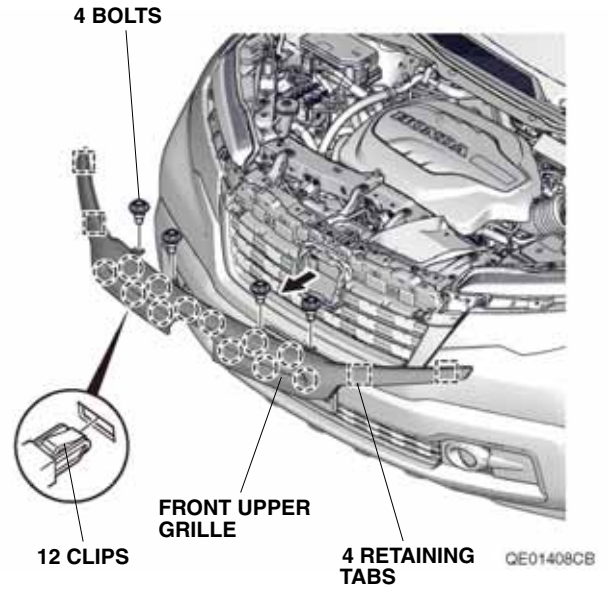

- Apply masking tape as shown on each side.

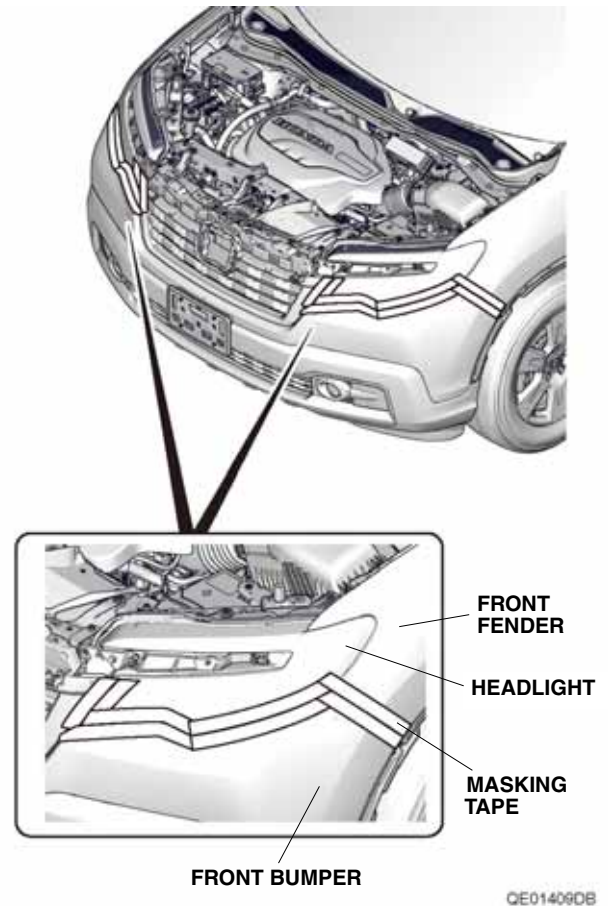

- Remove the four self-tapping screws, eight clips, four washer-bolts, and four flange bolts.

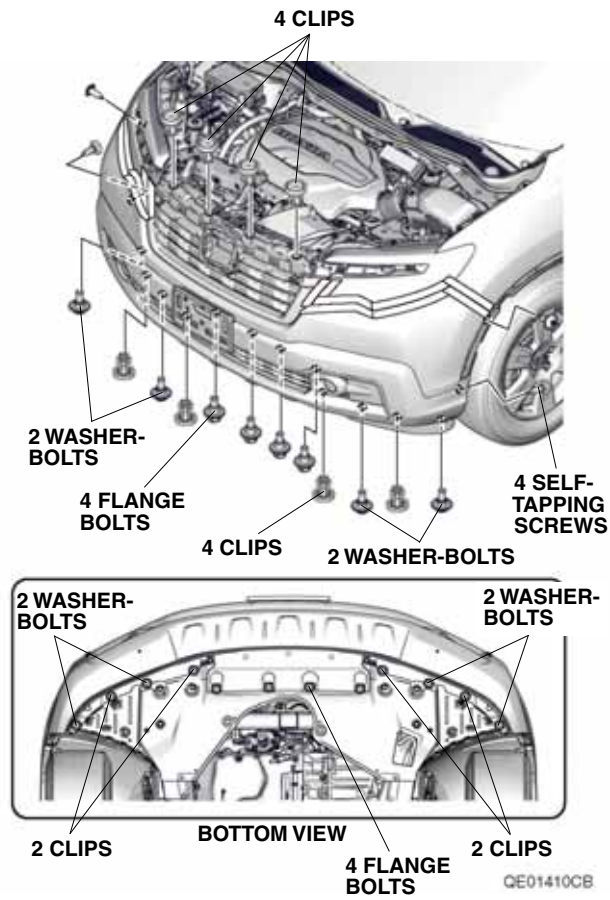

- With the help of an assistant, release the seven retaining tabs on each side.

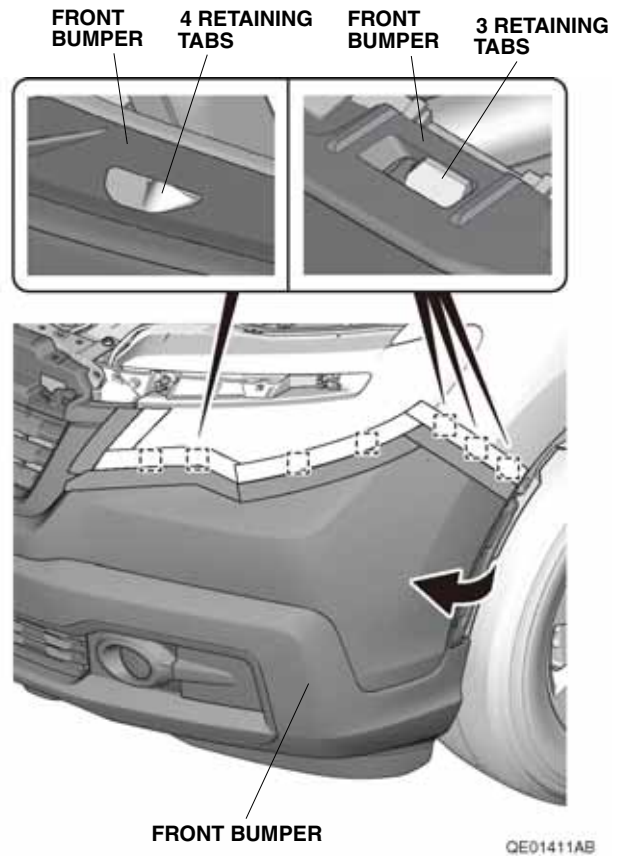

- Release the front grille.

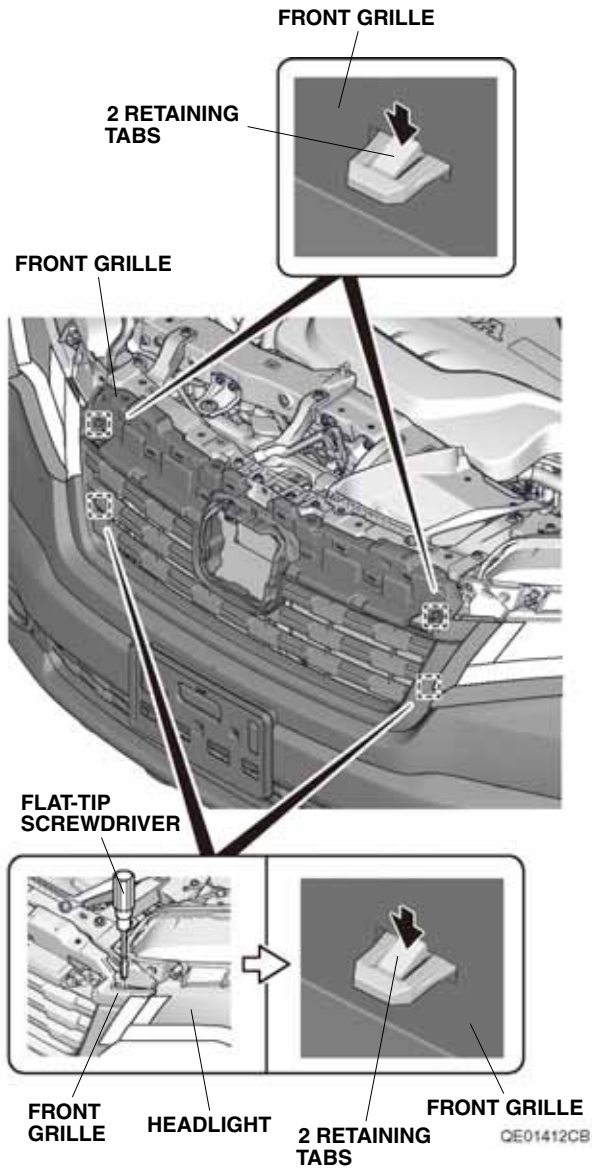

- With the help of an assistant, remove the front bumper and unplug the vehicle connector.
- Place the front bumper on a blanket.

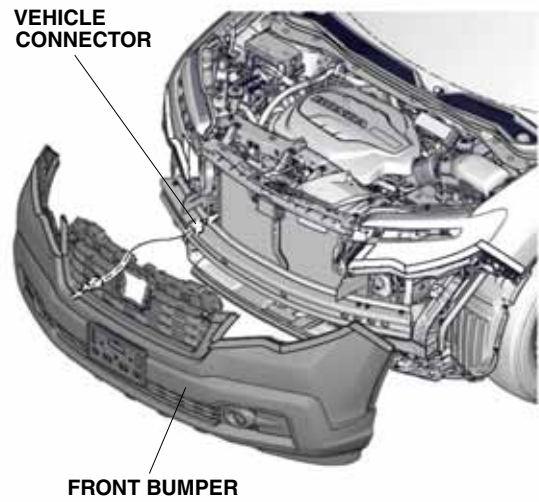

6. Turn the steering wheel fully clockwise.

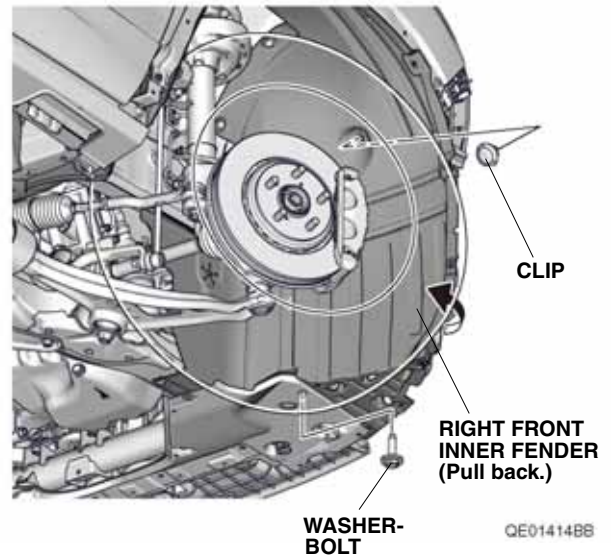

7. Remove one washer-bolt and one clip and pull back the right front inner fender as shown.

8. Remove the left cover from the front bumper.

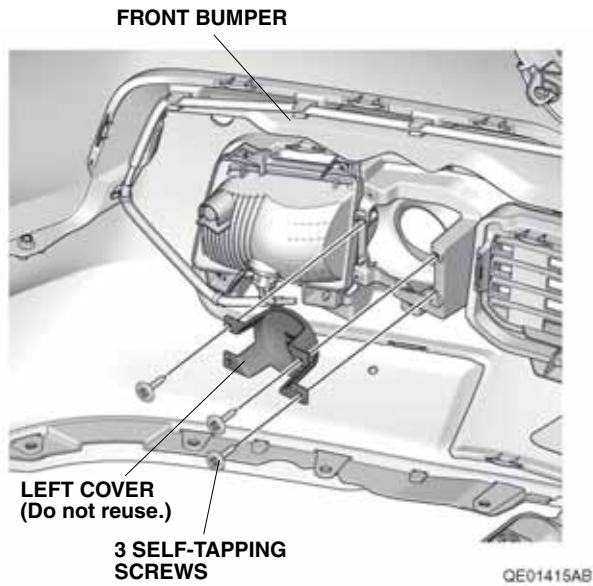

9. Install the left fog light on the front bumper with the three self-tapping screws removed in step 8.

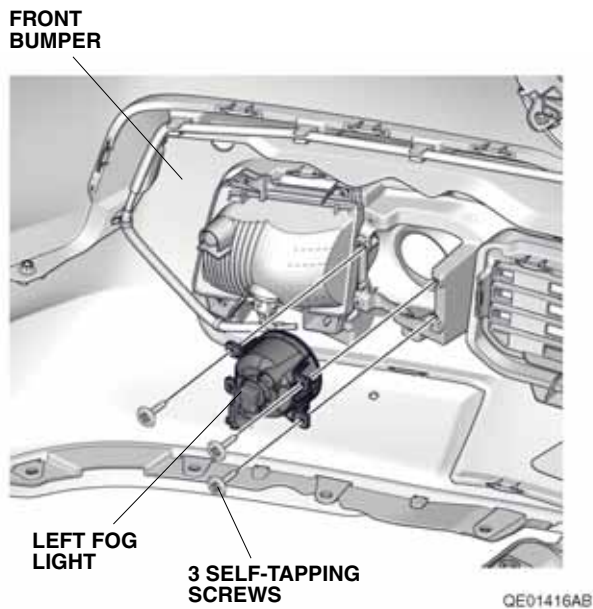

10. Repeat steps 8 and 9 to install the right fog light on the right side of the front bumper.

11. Plug the two fog light harness 2-pin connectors into the left and right fog lights.

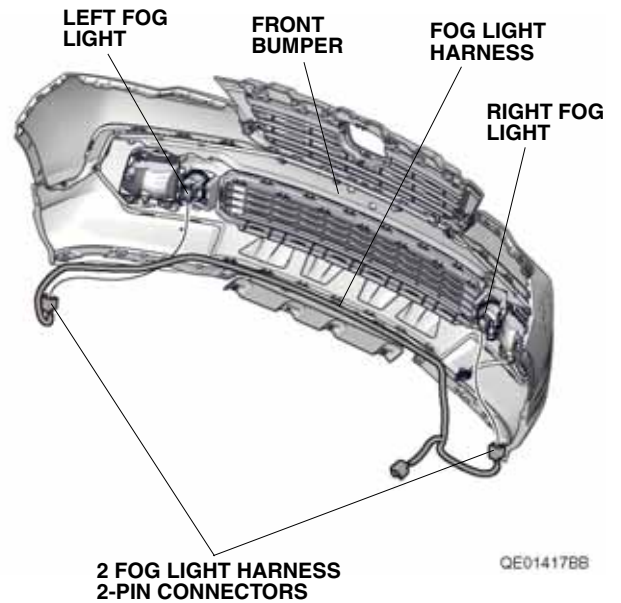

12. Secure the fog light harness to the two holes on the front bumper with two wire ties with clip on each side.

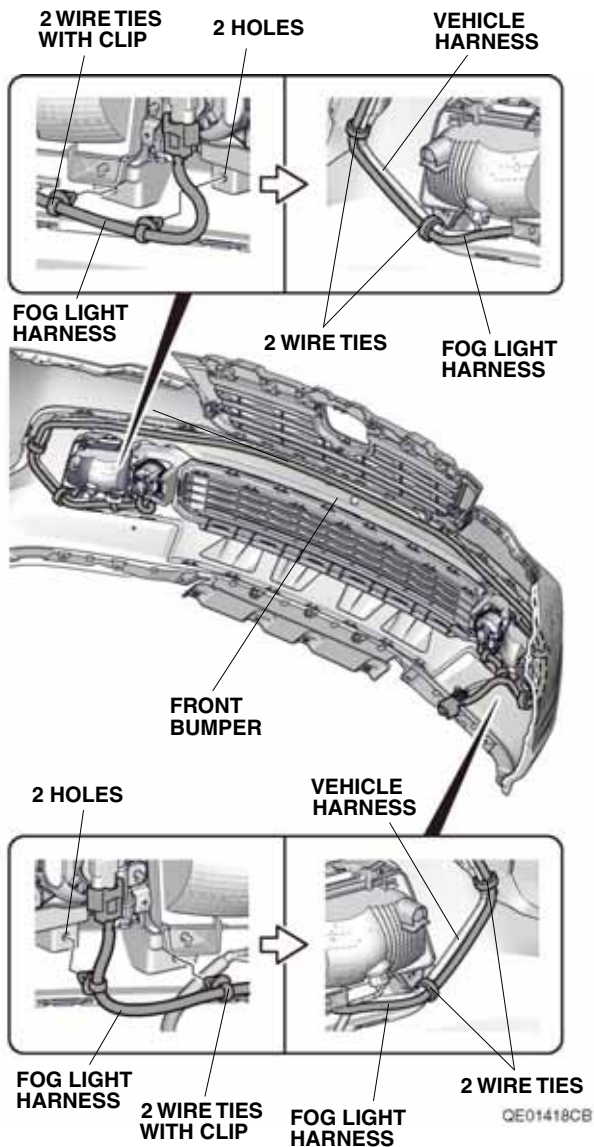

13. Secure the fog light harness to the vehicle harness with two wire ties on each side.

14. Secure the fog light harness to the vehicle harness with eight wire ties.

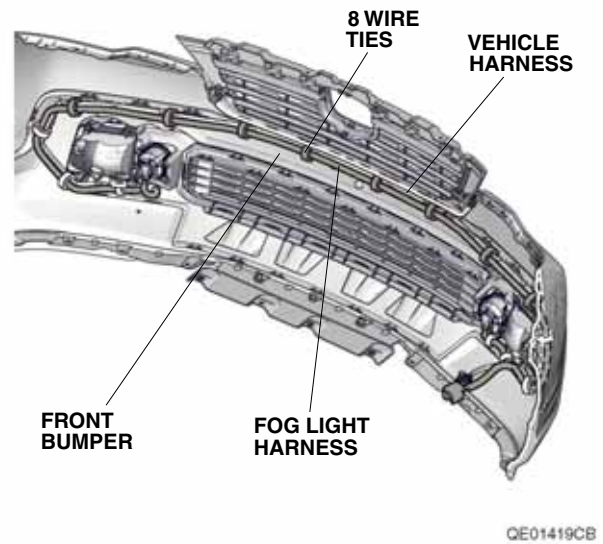

15. Remove the vehicle ground bolt and secure the ground harness ground terminal to the vehicle ground terminals with the vehicle ground bolt just removed. Do not put the ground terminal caulking on top of one another.

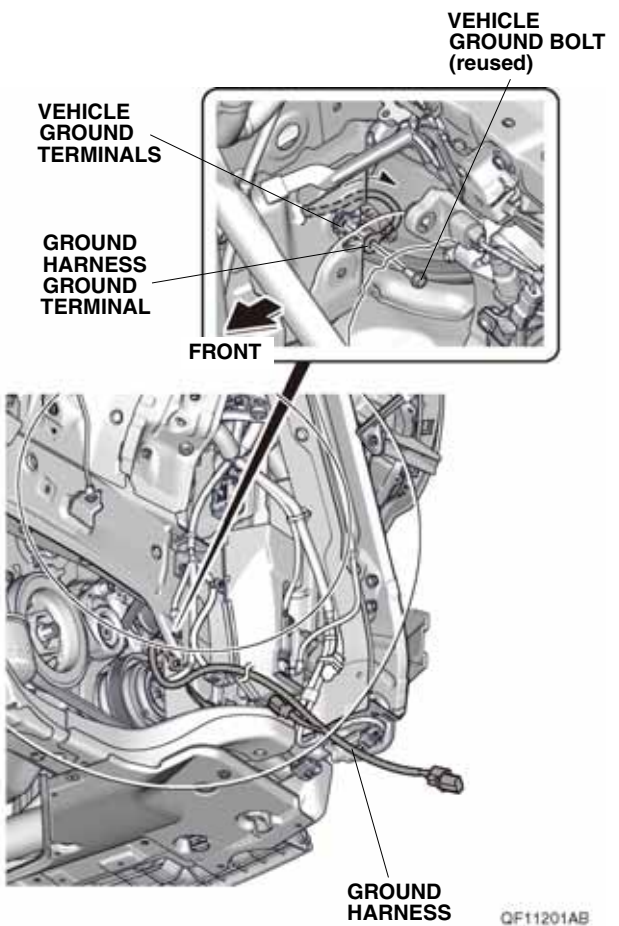

- Route the ground harness along the vehicle harness and secure it to the vehicle harness with three wire ties.

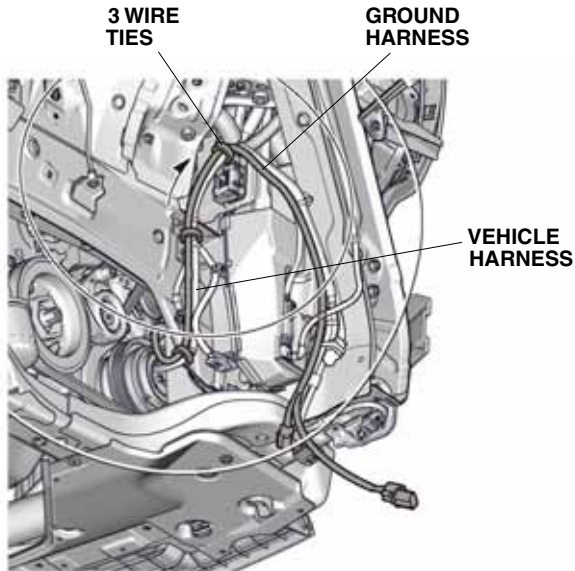

- Locate the vehicle 1-pin connector taped to the vehicle harness. Remove the tape to free the vehicle 1-pin connector. Remove the dummy connector from the vehicle 1-pin connector.

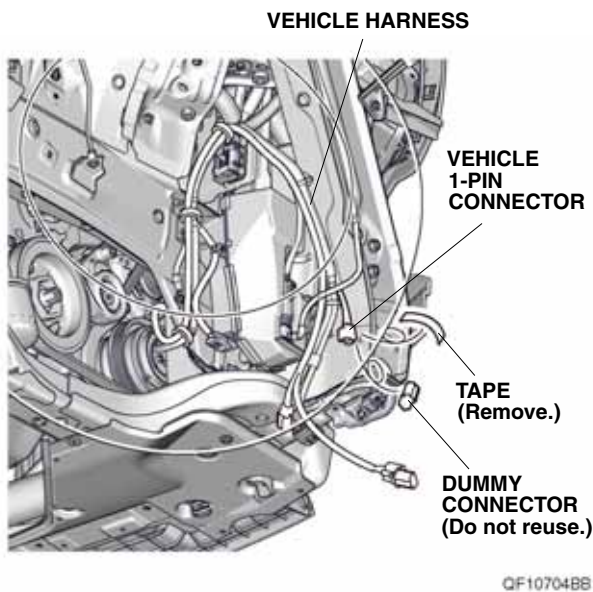

- Plug the ground harness 1-pin connector into the vehicle 1-pin connector.

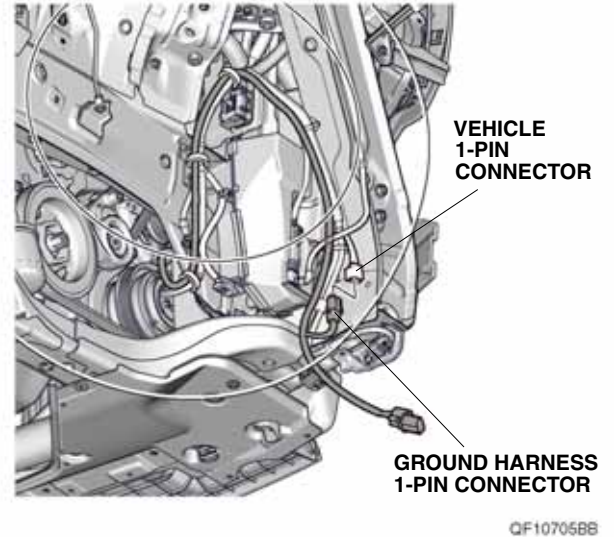

- Secure the ground harness to the vehicle harness with three wire ties.

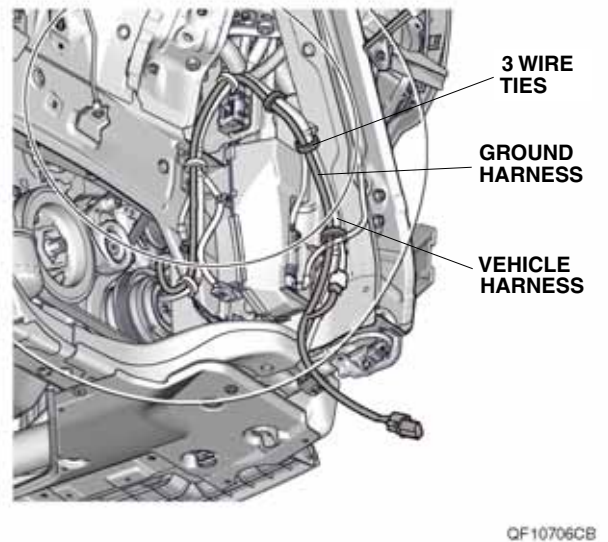

20. Install the wire tie with holder to the ground harness 1-pin connector.

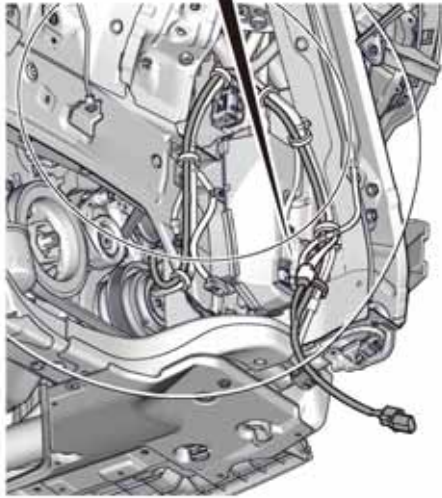
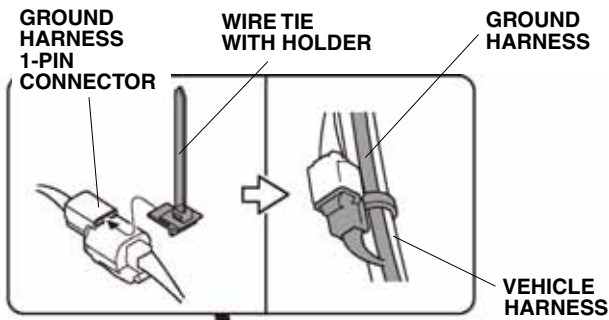

QF10707BB

21. Secure the 1-pin connectors and ground harness to the vehicle harness with the wire tie installed in step 20.

22. Install the wire tie with holder to the ground harness 2-pin connector.

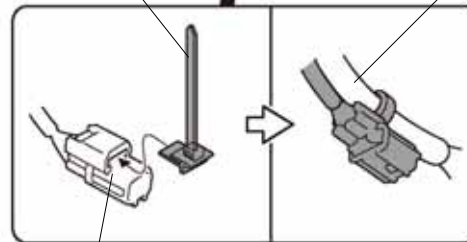
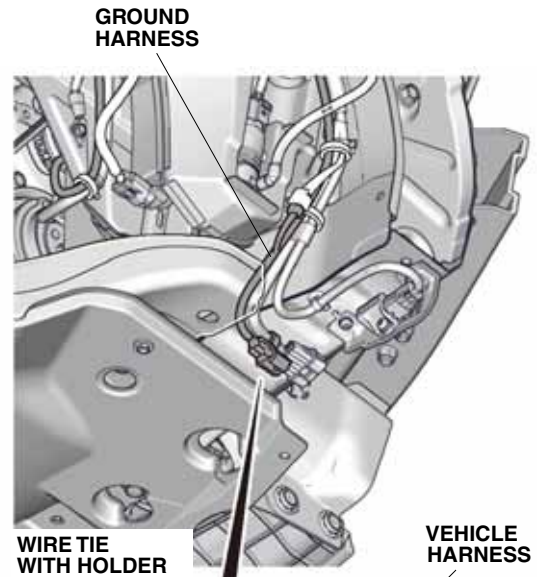

GROUND HARNESS 2-PIN CONNECTOR

QE01420CB

23. Secure the ground harness 2-pin connector to the vehicle harness with the wire tie installed in step 22. Reinstall the right front inner fender.

24. With the help of an assistant, bring the front bumper close into the vehicle. Plug the ground harness 2-pin connector to the fog light harness 2-pin connector, then install the front bumper.

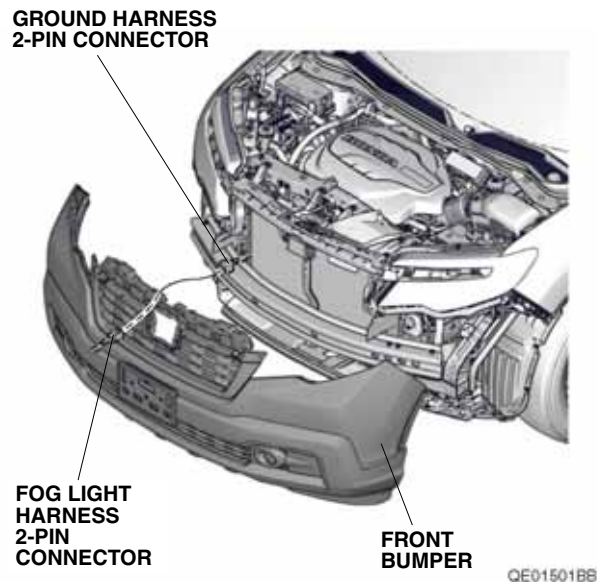

25. Under the hood, remove the relay box cover.

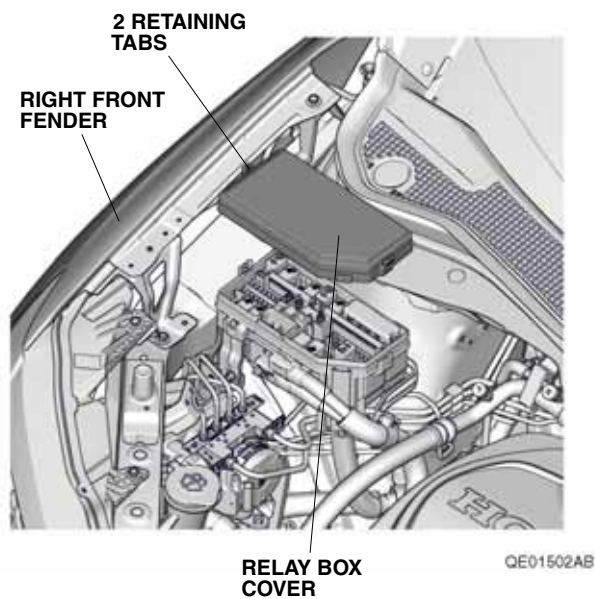

26. Plug the relay into the relay box in the slot shown.

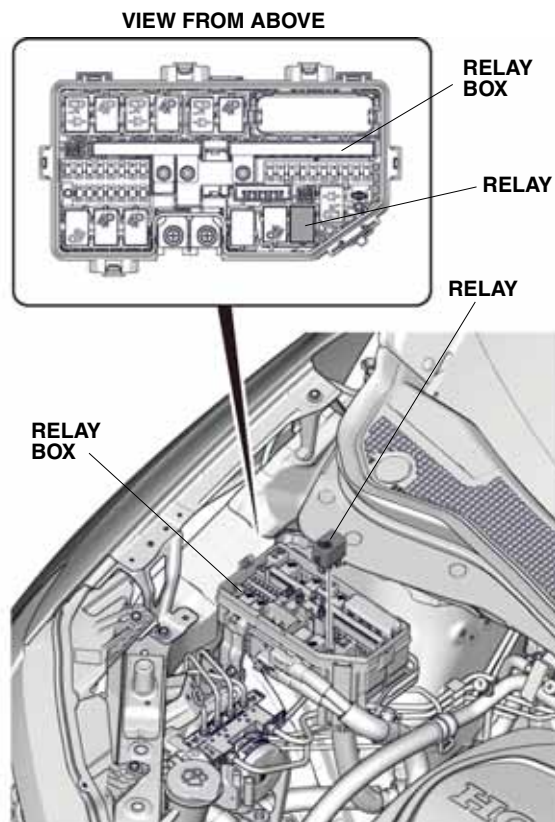

27. Pull away the door opening seal and remove the driver's dashboard side lid.

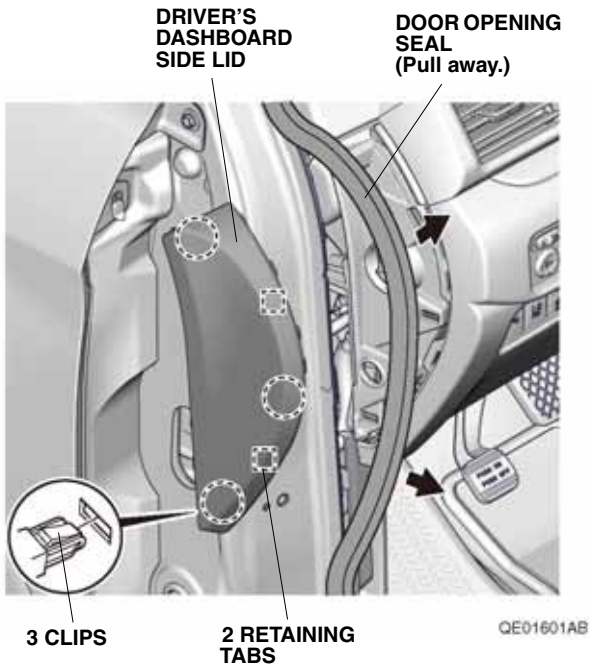

28. Remove the driver's dashboard lower cover and unplug the vehicle connectors and sensor.

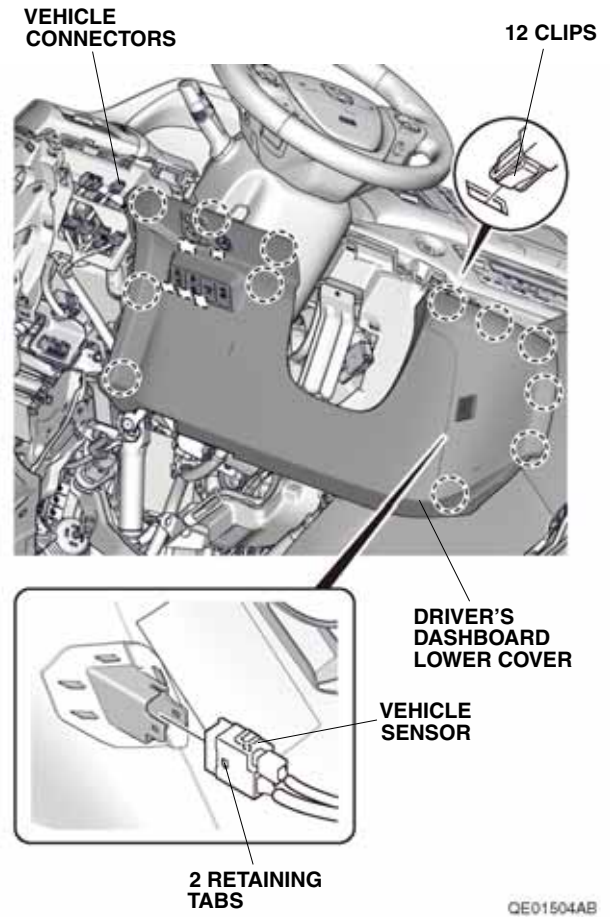

29. Lower and pull out the steering wheel as shown.

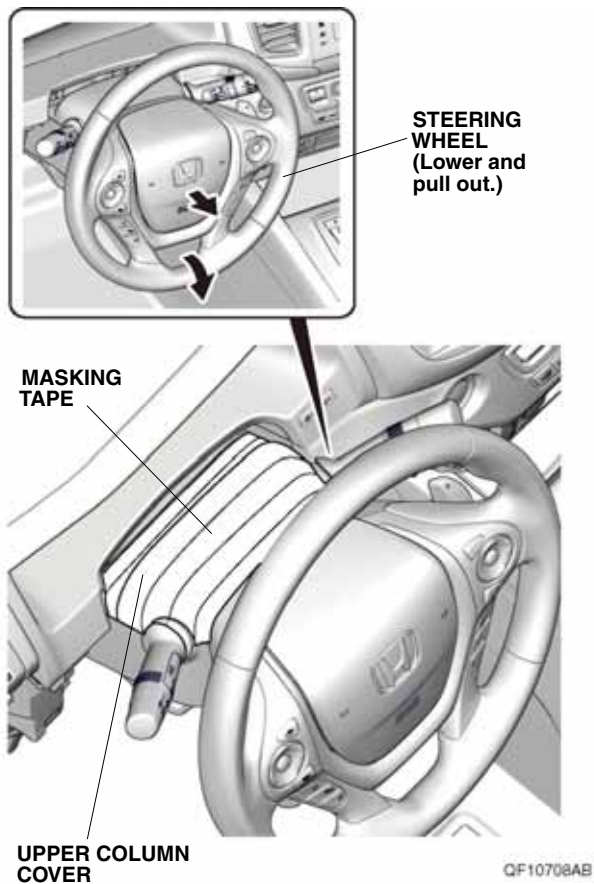

30. Apply masking tape to the upper column cover.

31. Connect the negative cable to the battery, then set the power mode to ON. Turn the steering wheel 90° counterclockwise. Using a plastic trim tool, release the upper column cover.

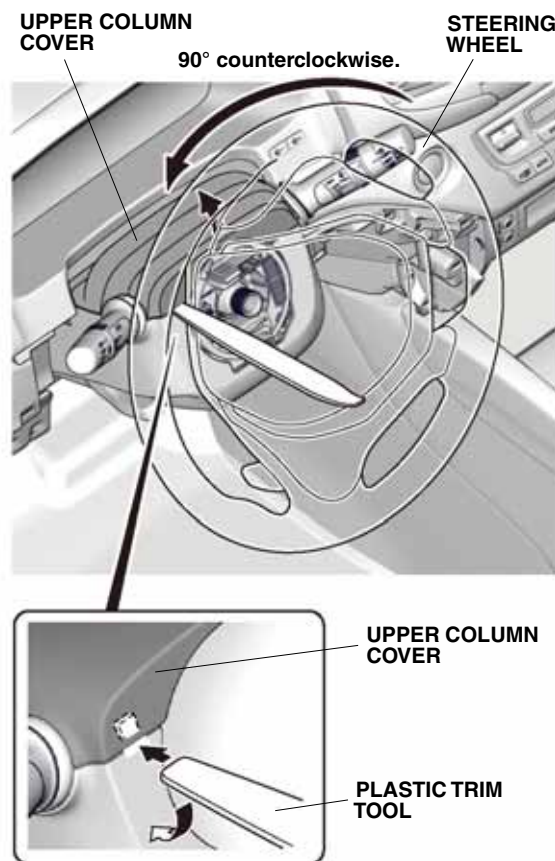

QF10709AB

32. Turn the steering wheel 180° clockwise. Using a plastic trim tool, release the upper column cover.

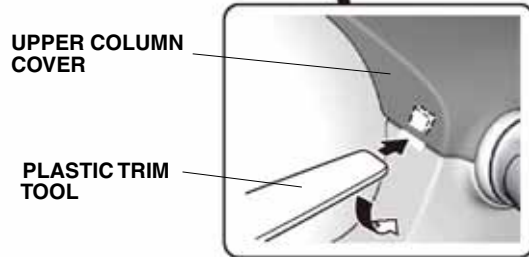
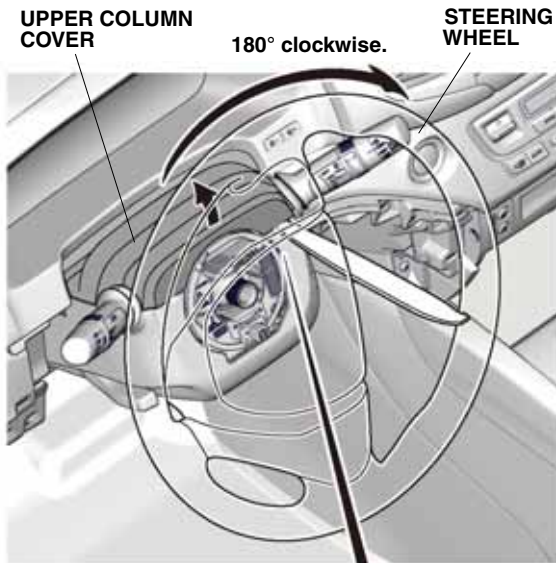

QF10710AB

33. Release the upper column cover and secure it to the dashboard with masking tape.

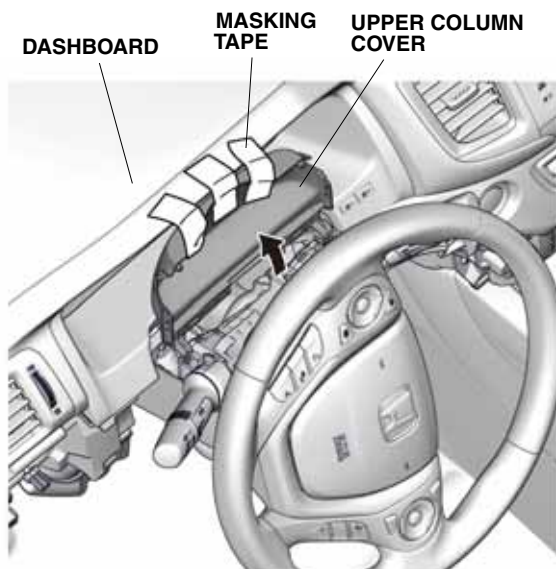

QF10713AB

34. Remove the one self-tapping screw from the lower column cover.

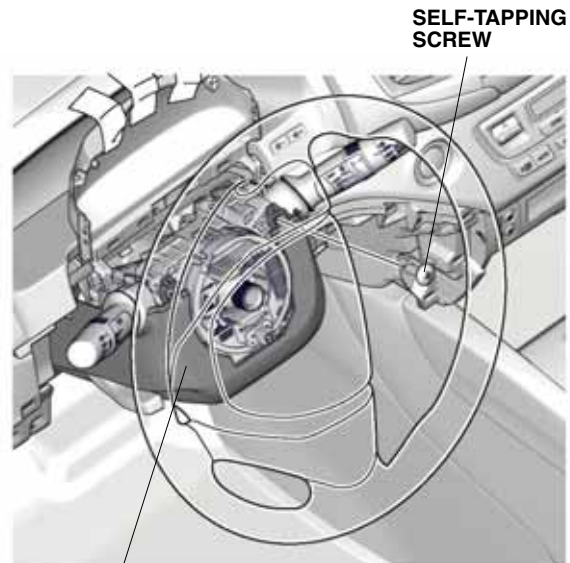

LOWER COLUMN COVER

QF10711AB

35. Turn the steering wheel 180° counterclockwise and remove the other self-tapping screw from the lower column cover.

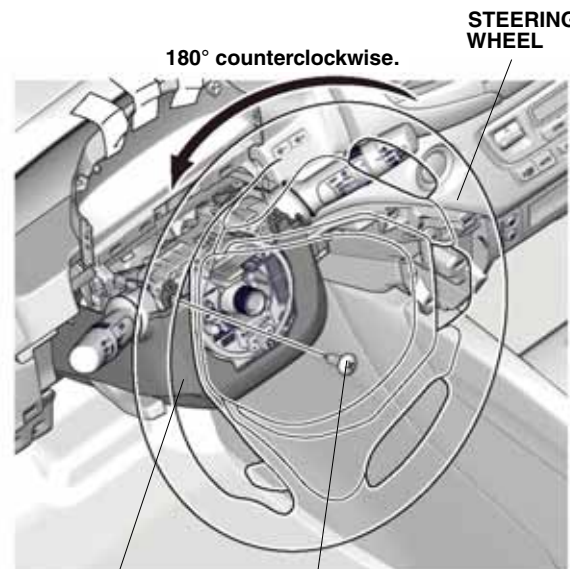

LOWER COLUMN COVER

SELF-TAPPING SCREW

QF10712AB

36. Remove the lower column cover.

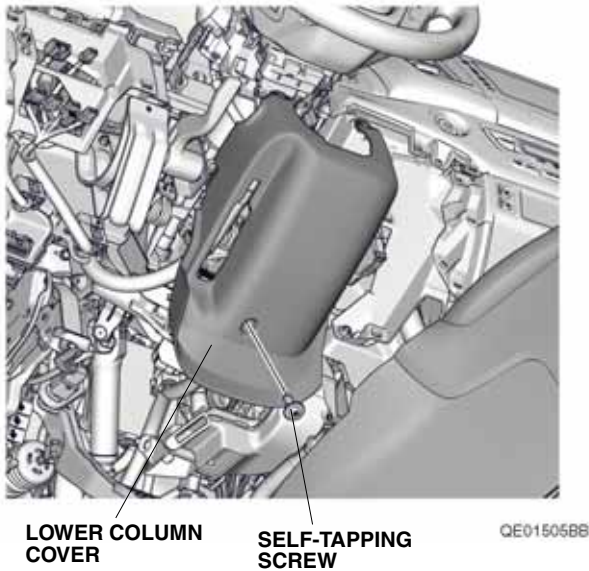

37. Set the power mode to OFF, then disconnect the negative cable from the battery.

38. Unplug the vehicle connector from the combination light switch.

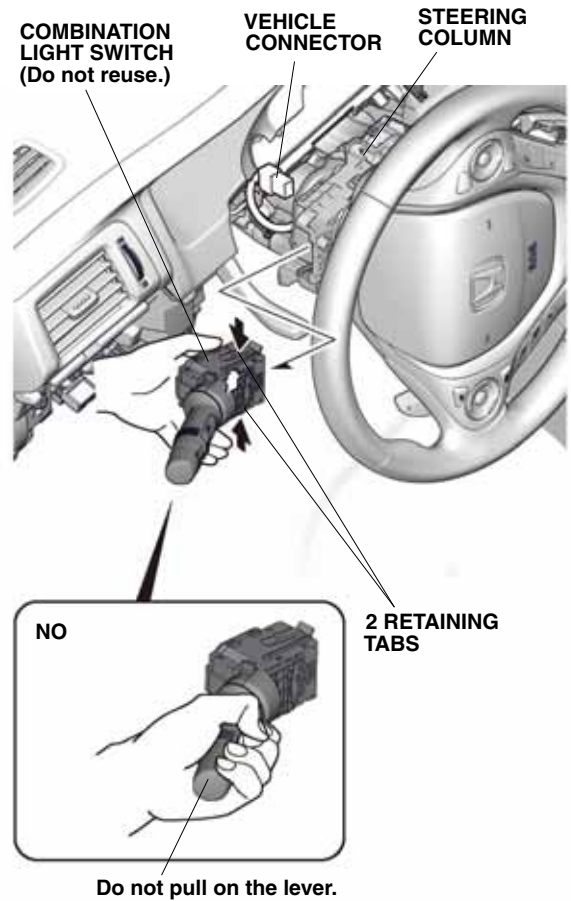

39. Push in on the two retaining tabs, slide the light switch out, and remove it from the steering column. Do not pull on the lever.

40. Install the new combination light switch to the steering column. Make sure both retaining tabs are locked in place. Do not push on the lever.

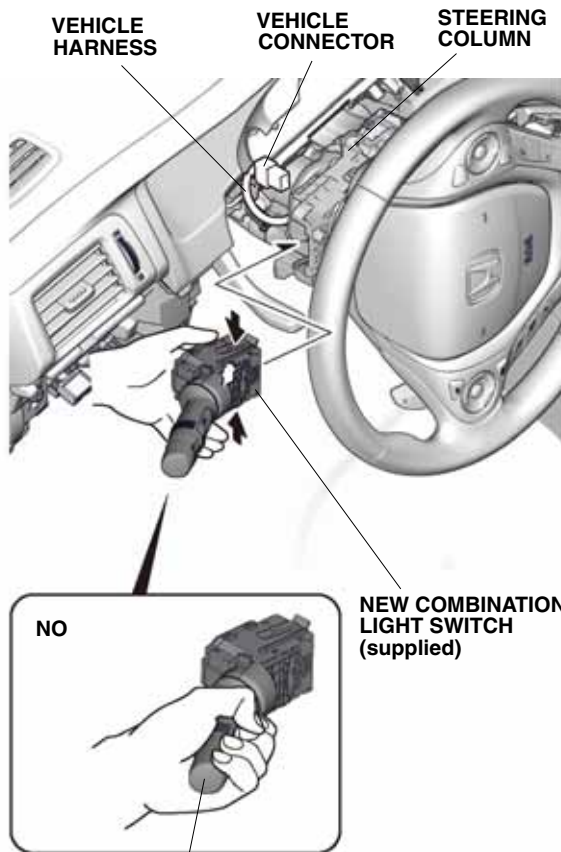

Do not push on the lever.

QDN2414BB

41. Plug the vehicle connector into the new combination light switch. Make sure the vehicle harness is not being stretched.
42. Check that all wire harnesses are routed properly and all connectors are plugged in.
43. Install all removed parts except for the front bulkhead cover and the intake air tube.
44. Connect the negative cable to the battery.
45. Install the front bulkhead cover and the intake air tube.
46. Press and hold the audio unit power button for 2 seconds to restore the audio and navi (if equipped) system functions.
47. Set the clock on vehicles without navigation.
48. If necessary restore the systems back to normal operation as described in the service information.

Check the Operation of the Fog Lights

49. Turn the headlight switch to the AUTO or “” position (headlights on low beam).
50. Turn on the fog light switch (indicator is on).
51. If the fog lights do not turn on, check the fuse and all the connectors, including the ground cable.

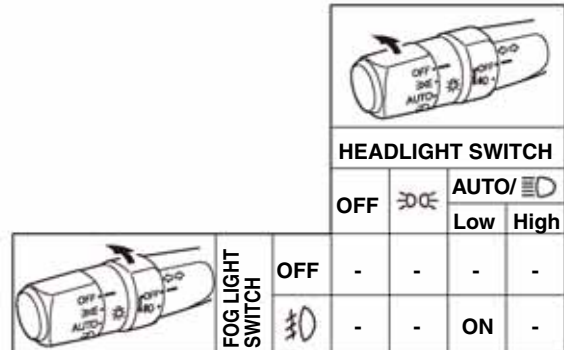

QD72302AG

NOTE: The fog light lenses may cloud when the outside temperature is cold; this is normal and should go away in warm weather.

How to Aim the Fog Lights

52. Adjust the fog light aim by turning the adjustment screw in or out until the correct aim is obtained. Adjust the aim according to local laws and regulations.

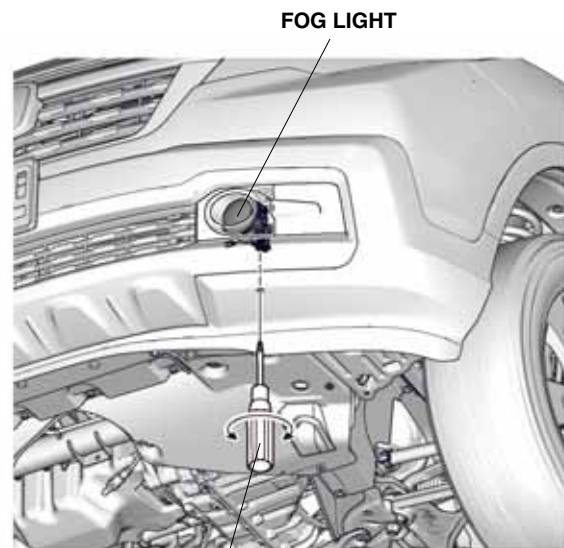

PHILLIPS SCREWDRIVER

QE01506BB

BULB REPLACEMENT

1. Release the left front inner fender.

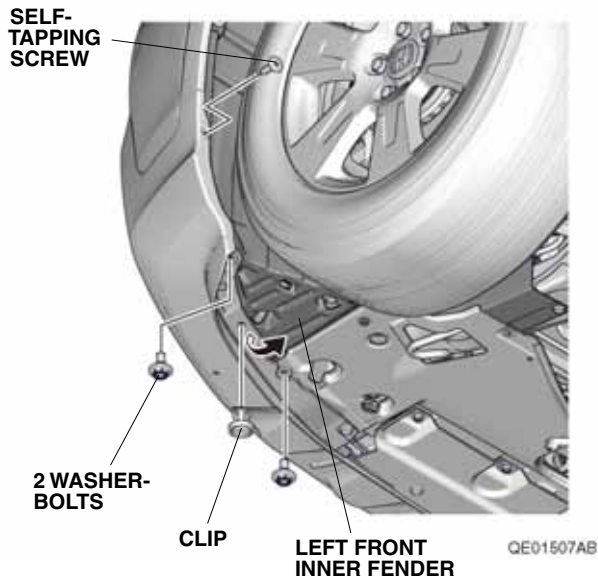

2. Insert your hand inside of the left front inner fender. Unplug the connector from the fog light.

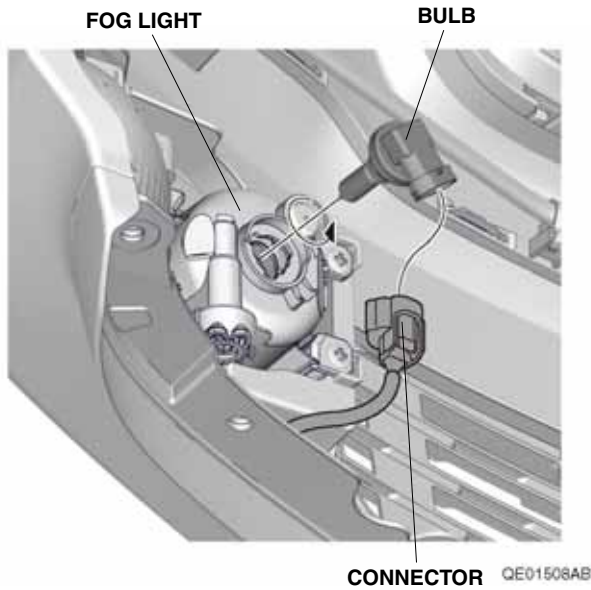

3. Remove the bulb from the fog light as shown. NOTE: Turn the fog light bulb counterclockwise.

4. Install the new bulb.
 - Use only a Genuine Honda halogen light bulb of specified wattage.

Rating: 12V 35W H8 Halogen Light Bulb
P/N 33165-TL0-003

- Do not touch the bulb. Oily or greasy substances on the bulb can shorten its service life due to the heat produced when the bulb is turned on. If the bulb is accidentally touched, wipe it clean with a soft cloth that has been dampened with denatured alcohol or a mild detergent solution.
- When installing the new bulb, align the cutout on the fog light with the tab on the new bulb and turn the new bulb in completely. If not properly aligned, the fog light may annoy oncoming drivers.

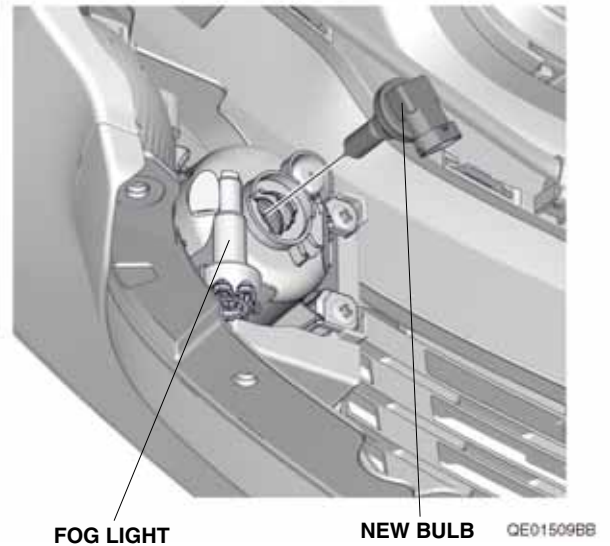
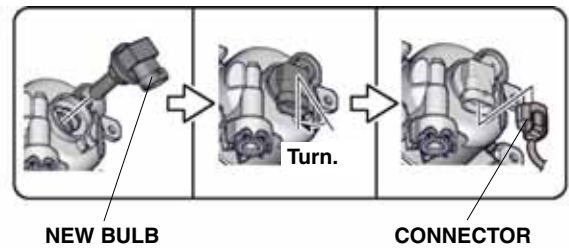

5. Install the removed parts. Check that the wire harnesses are not pinched. Be sure to tighten the screw, clip, and bolts securely.
6. Check the operation of the fog light; adjust the aiming if necessary.