

PARTS LIST
**Backup Sensors Attachment Kit
P/N 08V67-TG7-100A**

Control unit



Buzzer



Switch



Backup sensor harness

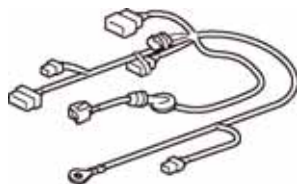

Subharness

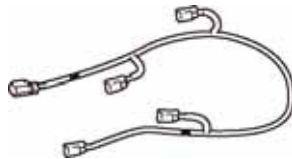

Control unit bracket



Center sensor clip (Black)



Center sensor clip (White)



2 Corner sensor clips (White)



Switch bracket



8 Wire ties



3 Narrow wire ties



Wire tie with holder



Connector clip
(May not be used)



Aluminum tape



Fuse label



Flange bolt



Accessory user's information manual



**Backup Sensors Kit
P/N 08V67-TG7-100K**

NOTE: Refer to Parts Information Bulletin (PIB) for the proper color sensors.

Left center sensor

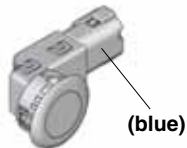

Right center sensor

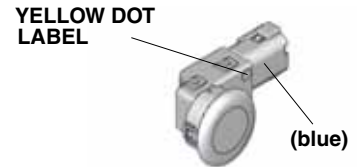

2 Corner sensors

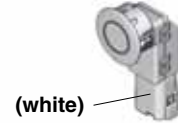

TOOLS AND SUPPLIES REQUIRED

- Phillips screwdriver
 - Impact screwdriver
 - Small flat-tip screwdriver
 - 10 mm Open end wrench
 - 10 mm Socket
 - Pushpin
 - Ratchet
 - 3 mm Drill bit
 - Eye protection (face shield, safety goggles, etc.)
 - File
 - Hex wrench
 - Blanket
 - Isopropyl alcohol
 - Shop towel
 - 24 mm and 26 mm Hole saws
 - Drill
 - Masking tape
 - Diagonal cutters
- The following tool is available through the Honda Tool and Equipment Program. On the iN, click on: Service > Service Bay > Tool and Equipment Program, then enter the number under "Search." Or, call 888-424-6857.*
- Plastic Trim Tool (T/N SILTRIMTL10)

Illustration of the Backup Sensors on the Vehicle

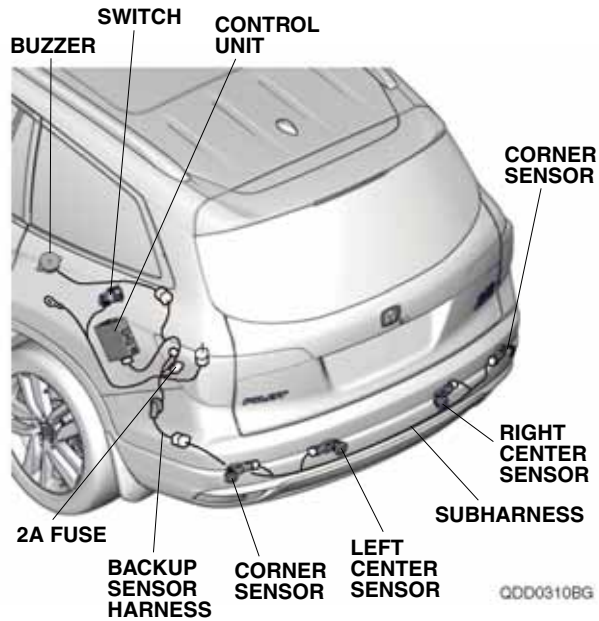

INSTALLATION

Customer Information: The information in this installation instruction is intended for use only by skilled technicians who have the proper tools, equipment, and training to correctly and safely add equipment to your vehicle. These procedures should not be attempted by “do-it-yourselfers.”

NOTE: Refer to Parts Information Bulletin (PIB) for the proper color sensors.

1. Open the tailgate.
2. Wrap a shop towel around the hood latch.

HOOD LATCH
(Wrap with a shop towel.)

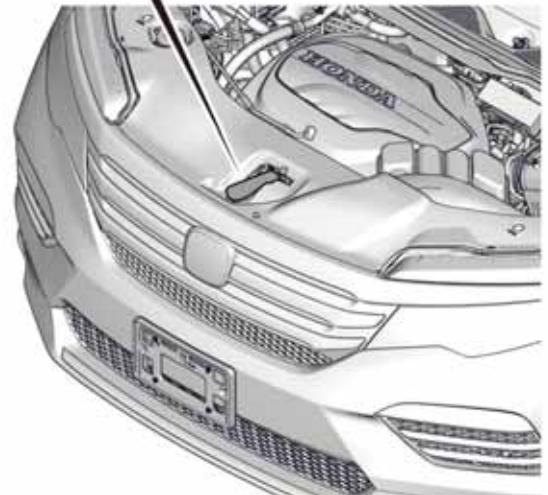
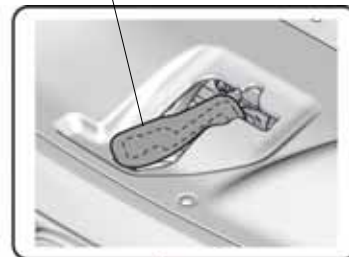

QDN1301AA

- Remove the front bulkhead cover.

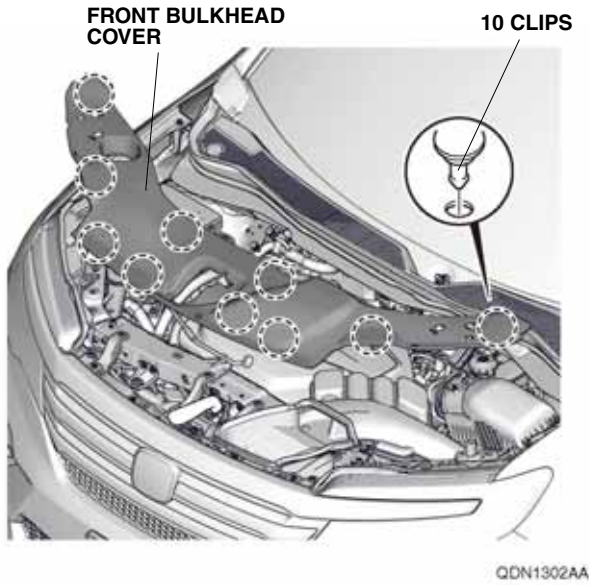

- Remove the intake air tube.
- Disconnect the negative cable from the battery.

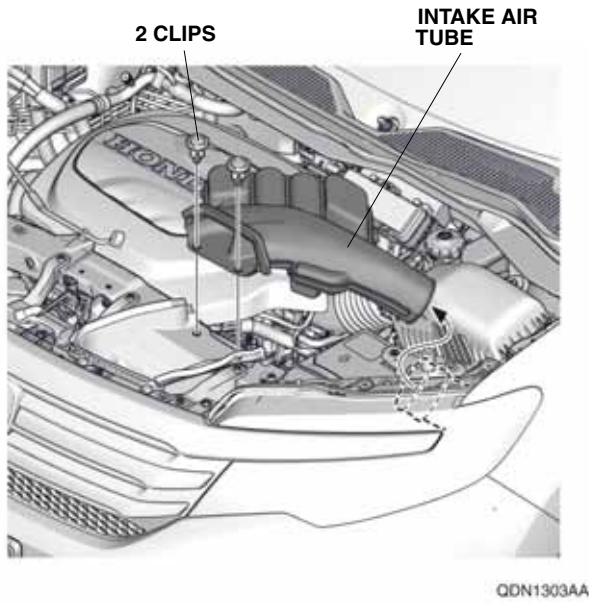

- Pull each strap, and fold down the third row seats.

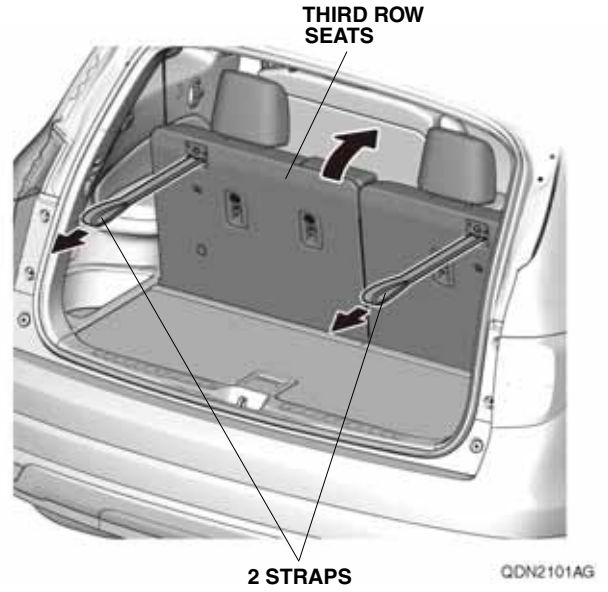

- Remove the cargo lid.

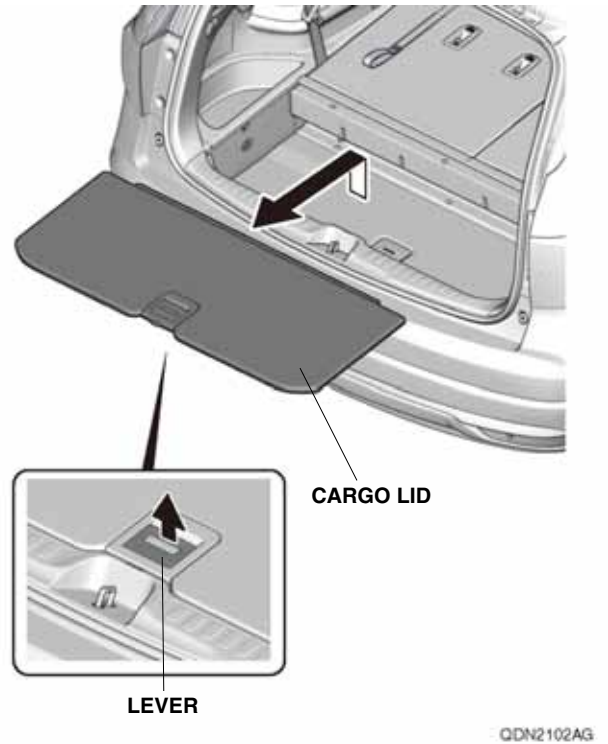

5. Remove the cargo bin divider.

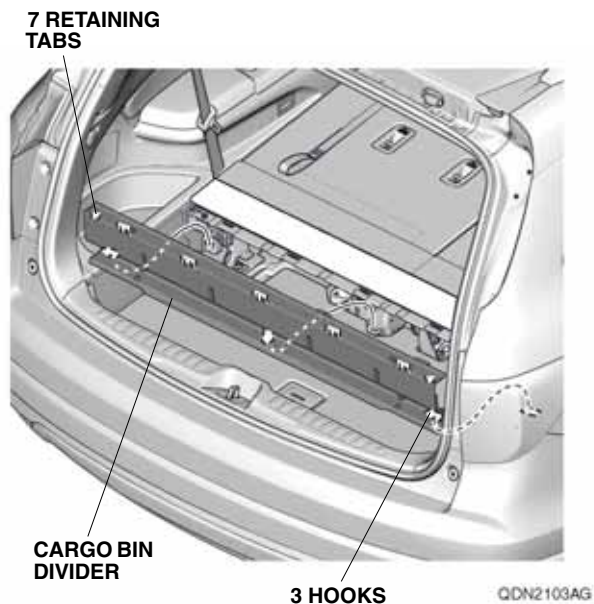

6. Release the eleven hooks from the vehicle frame.

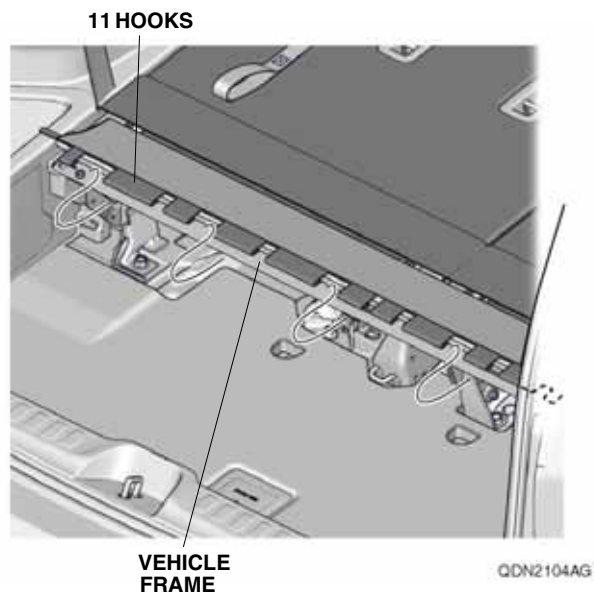

7. Remove the vehicle frame from the left and right rear side trim panel.

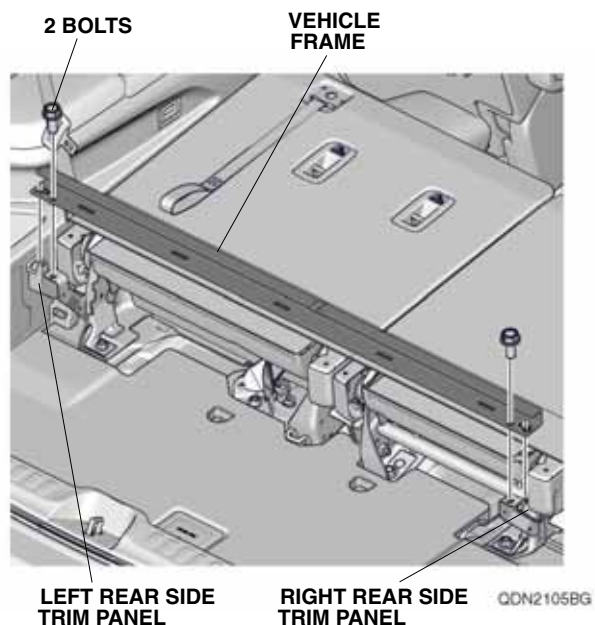

8. Remove the rear trim panel.

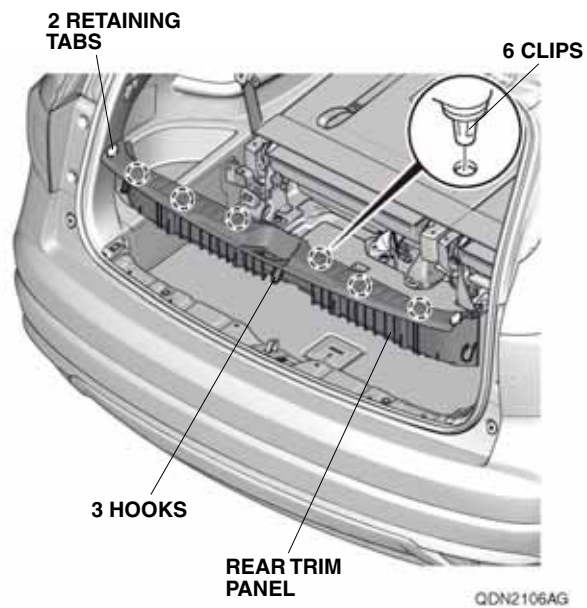

9. Fold down the left second row seat, and move it forward.



QDN2107AG

10. Remove the left rear upper door sill trim.

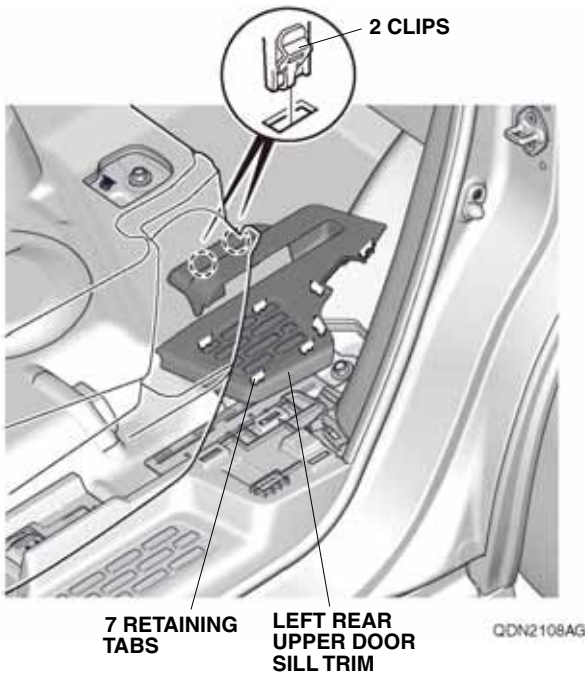

QDN2108AG

11. Using an impact screwdriver, remove the two tie-down hooks.

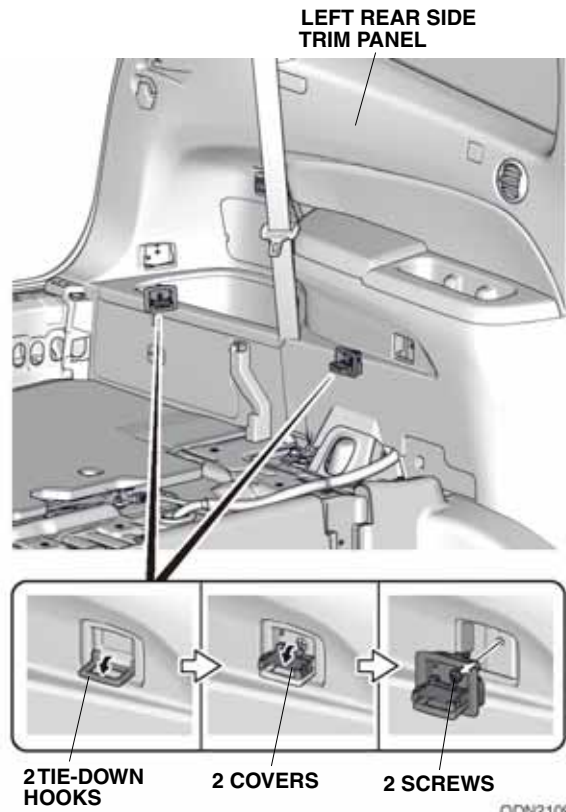

QDN2109AG

12. Remove the cargo hook.

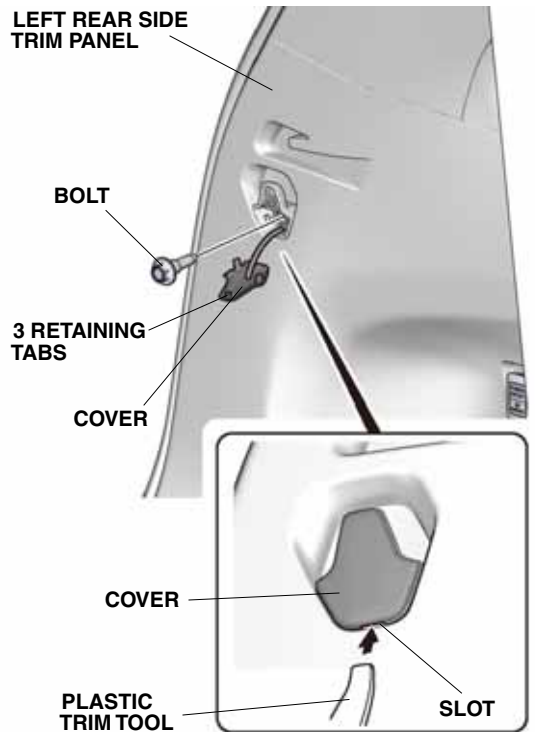

QDN2401AG

13. Pull the cover, and remove the screw.

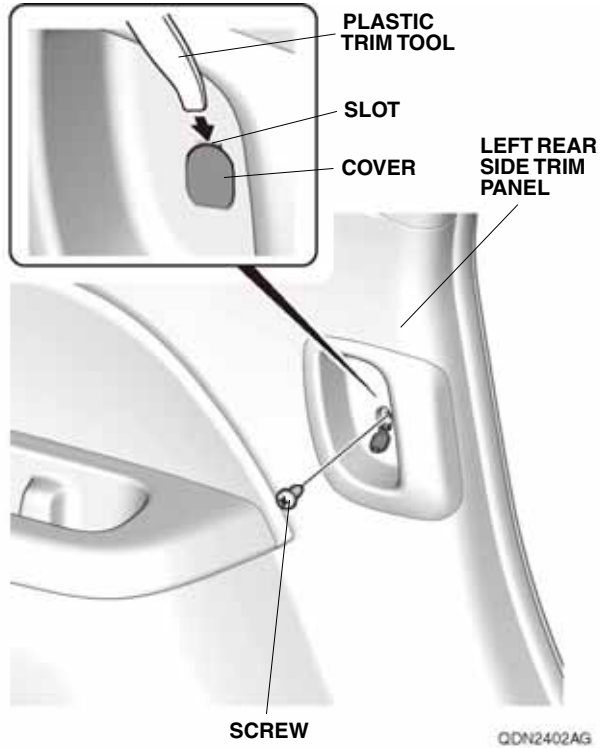

14. Attach masking tape to the left quarter pillar trim as shown.

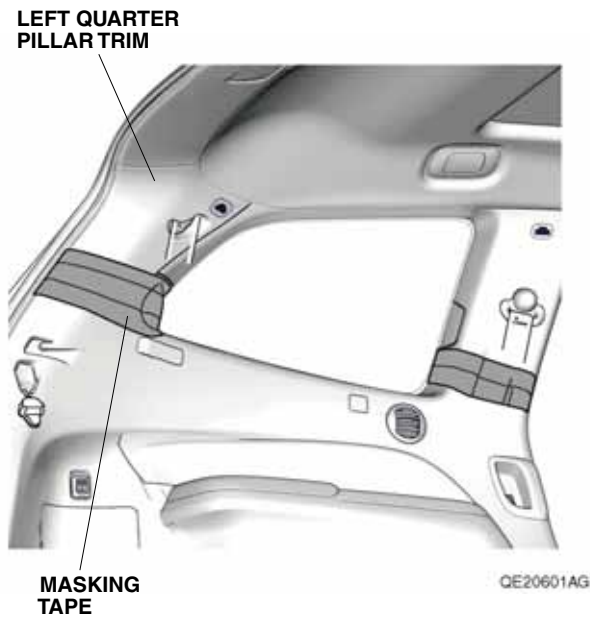

15. Remove the left rear side trim panel and unplug the vehicle connector.

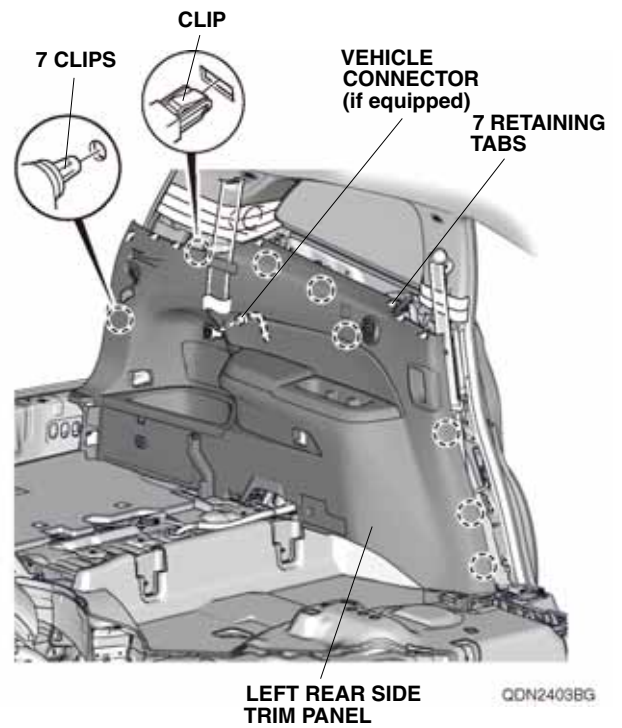

16. Open the right rear door.

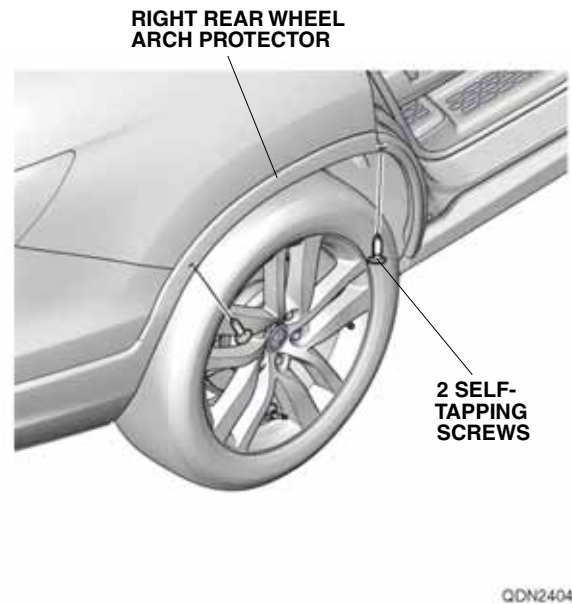

17. Remove the two self-tapping screws from the right rear wheel arch protector.

18. Release the right rear wheel arch protector.

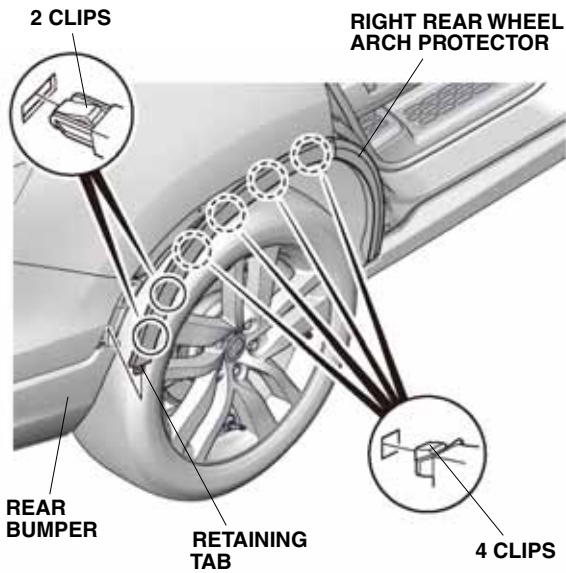

QDN2405BG

19. Release the left rear wheel arch protector the same way.

20. On each side of the vehicle, attach masking tape to the rear bumper, taillight and rear fender as shown.

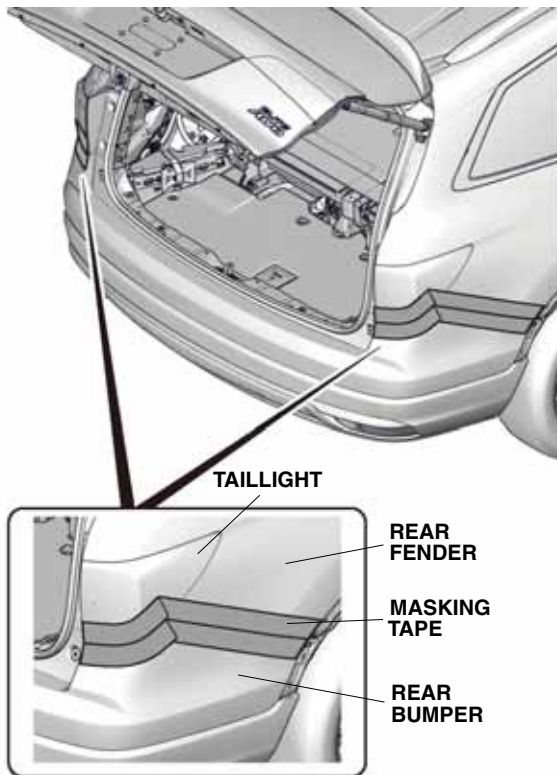

QDN2406AG

21. Remove the rear bumper:

- Remove the two bumper screws, ten self-tapping screws, and three clips.

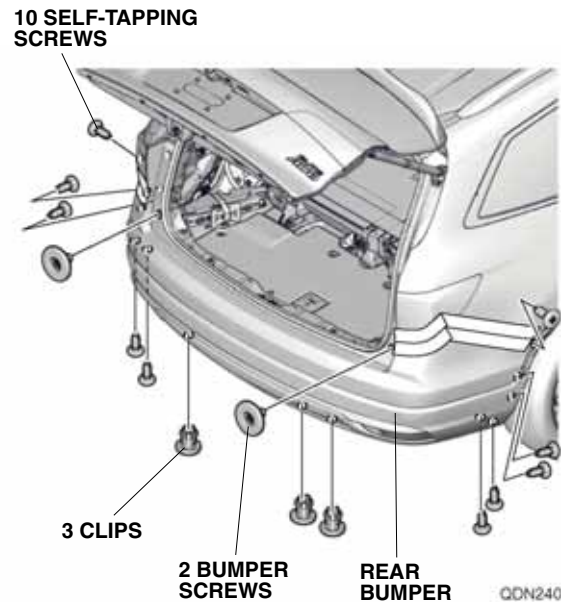

QDN2407BG

- On each side, release the nine retaining tabs along the fenderwell.

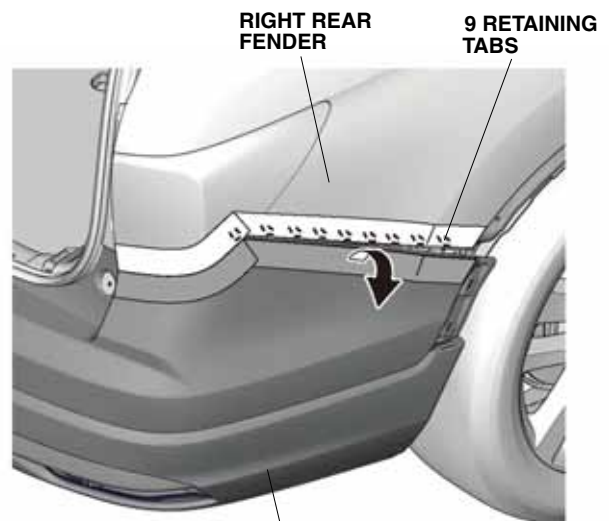

QDN2408AG

- On each side, release the two retaining tabs.

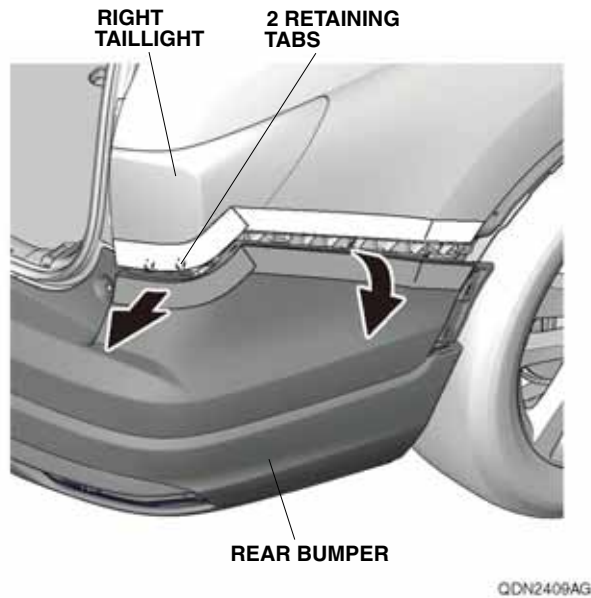

- With the help of an assistant, remove the rear bumper and unplug the vehicle connectors.
- Place the rear bumper on a blanket after removal.

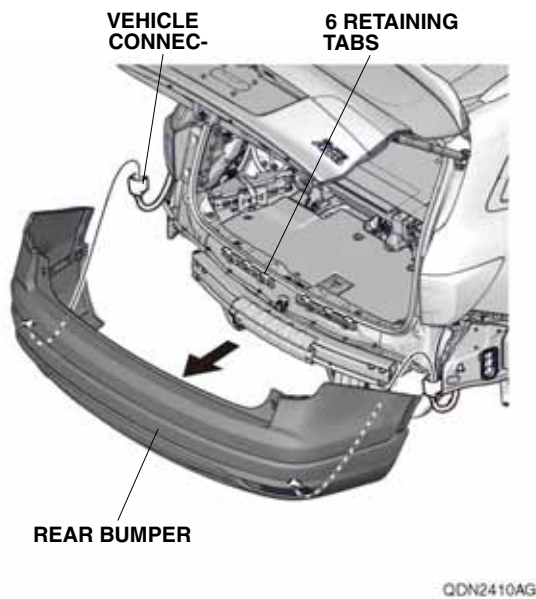

- Using isopropyl alcohol on a shop towel, thoroughly clean the fuse case where the fuse label will attach. Attach the 2A fuse label to the fuse case on the backup sensor harness.

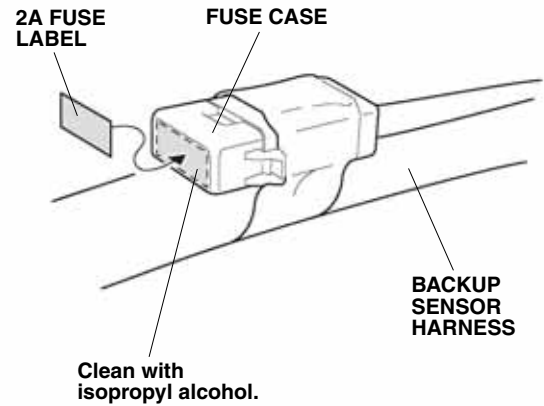

- Adjust the volume control knob on the control unit as shown.
NOTE: Do not turn the volume knob excessively, it may damage the control unit.

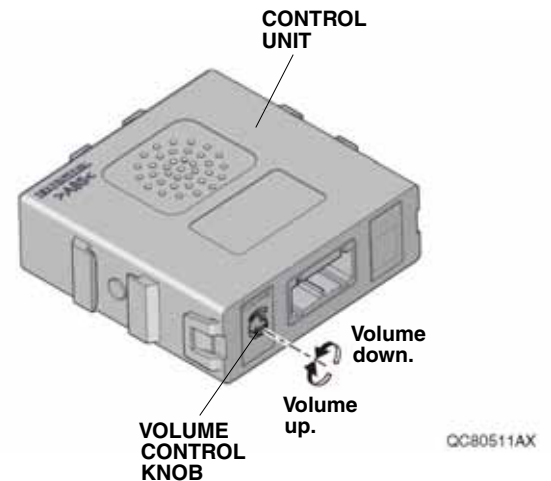

24. Install the control unit bracket to the control unit.

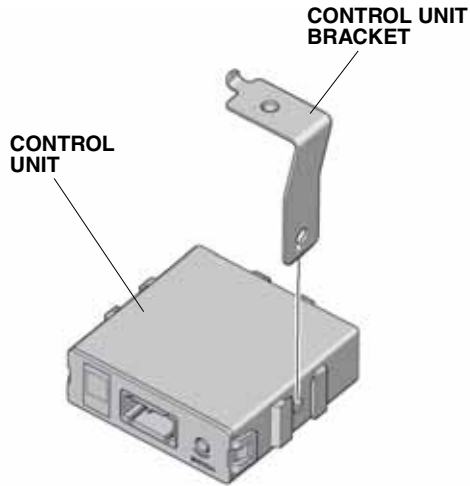

QDD0201AG

25. Insert the control unit bracket into the hole in the vehicle panel, and secure it with one flange bolt.

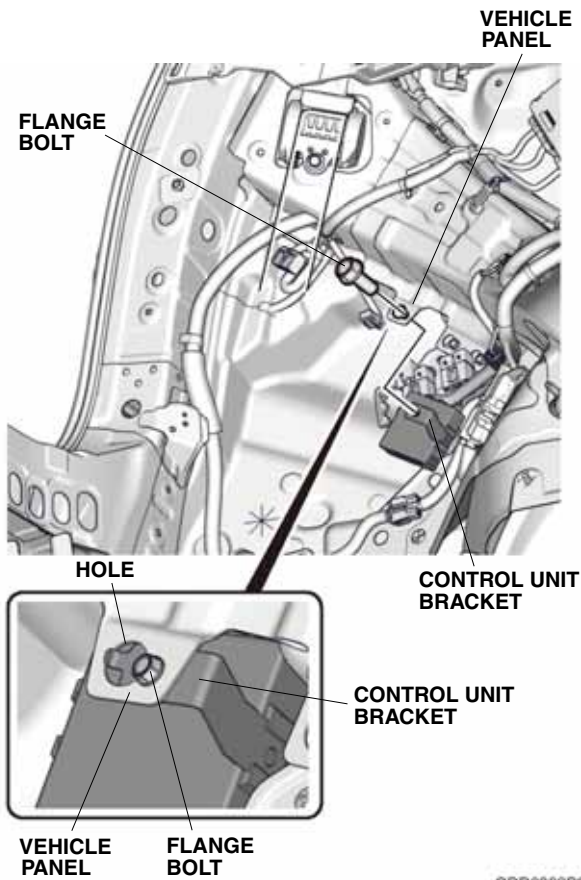

QDD0202BG

26. Plug the backup sensor harness 14-pin connector into the control unit.

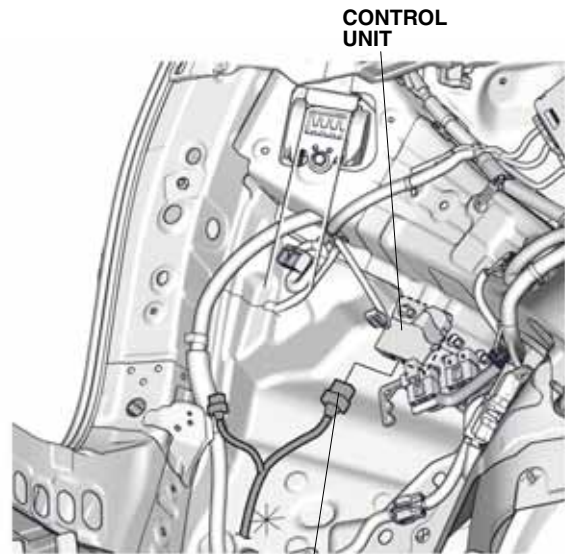

QDD0203BG

- If the vehicle is equipped with the trailer hitch harness, continue with step 27; otherwise, go to step 30.

With Trailer Hitch Harness

27. Remove the tape to free the trailer hitch harness 14-pin connector.

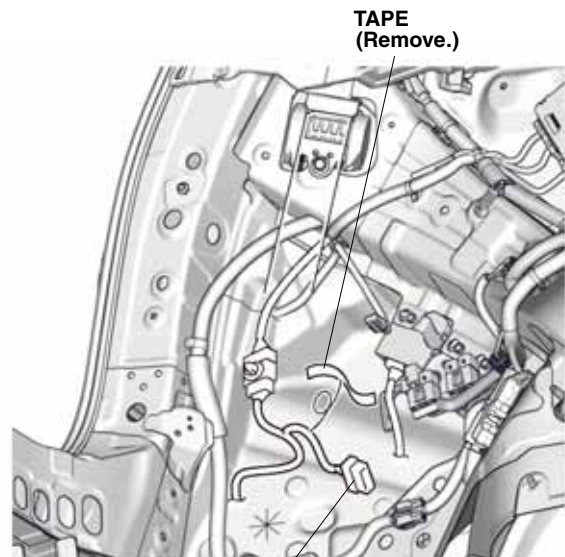

QDD0204CG

28. Plug the trailer hitch harness 14-pin connector into the backup sensor harness 14-pin connector.

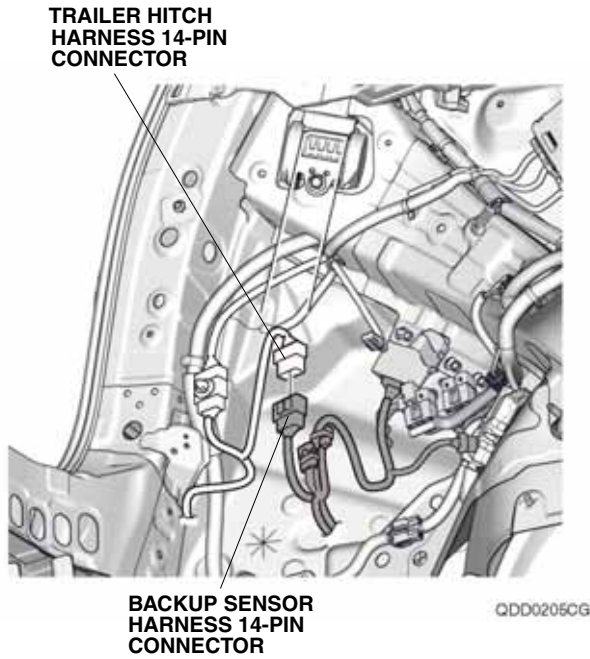

29. Install the 14-pin connectors to the trailer hitch harness 14-pin connectors as shown. Go to step 31.

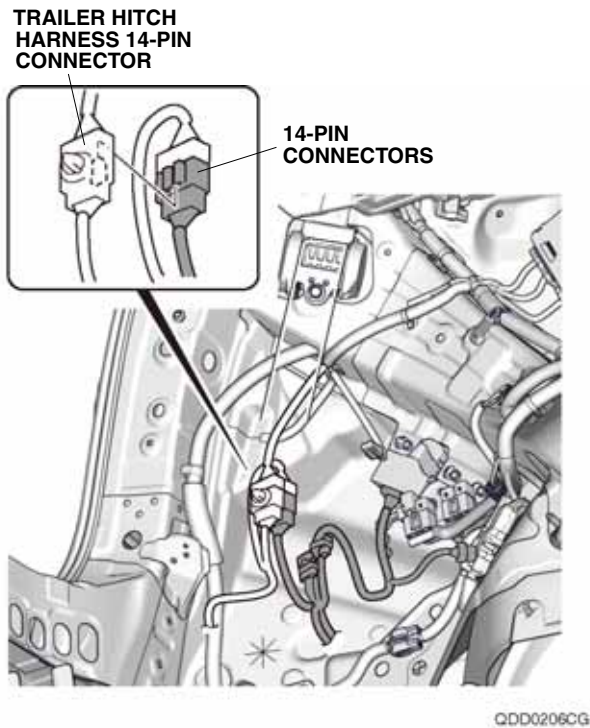

Without Trailer Hitch Harness

30. Remove the tape to free the vehicle 14-pin connector, and plug it into the backup sensor harness 14-pin connector.

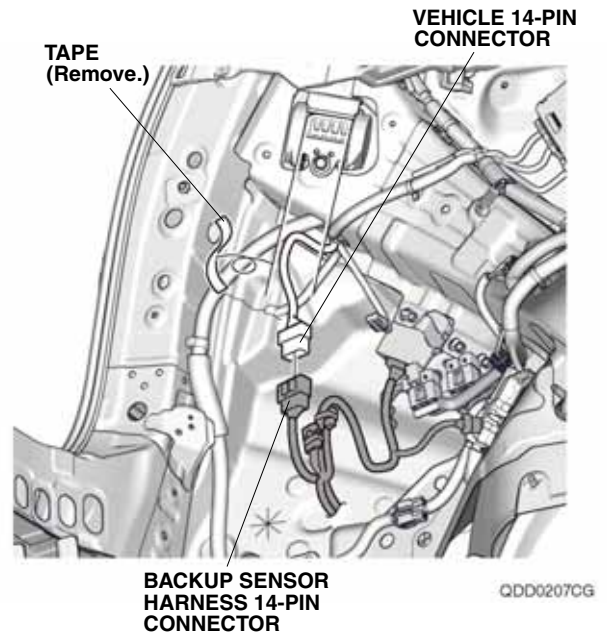

31. Remove the vehicle grommet. Route the backup sensor harness 8-pin connector through the slit and the vehicle grommet hole.

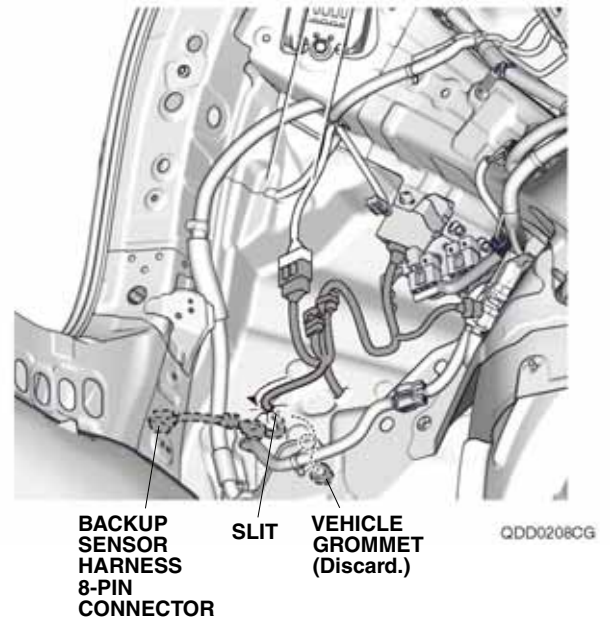

32. Secure the backup sensor harness grommet into the vehicle grommet hole.

NOTE:

- Install the backup sensor harness by holding the grommet.
- Make sure to check that the grommet is secured properly.

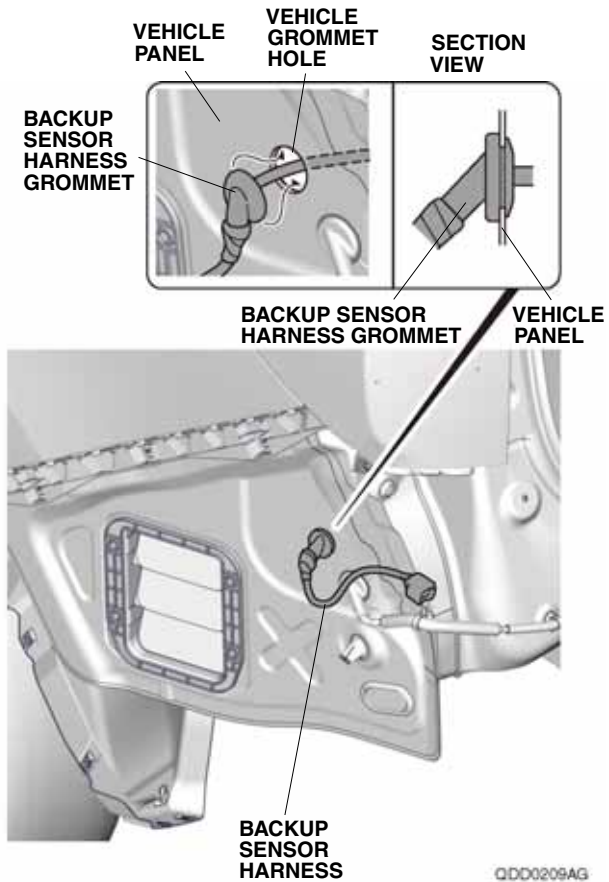

33. Secure the backup sensor harness 8-pin connector to the vehicle harness with one wire tie with holder.

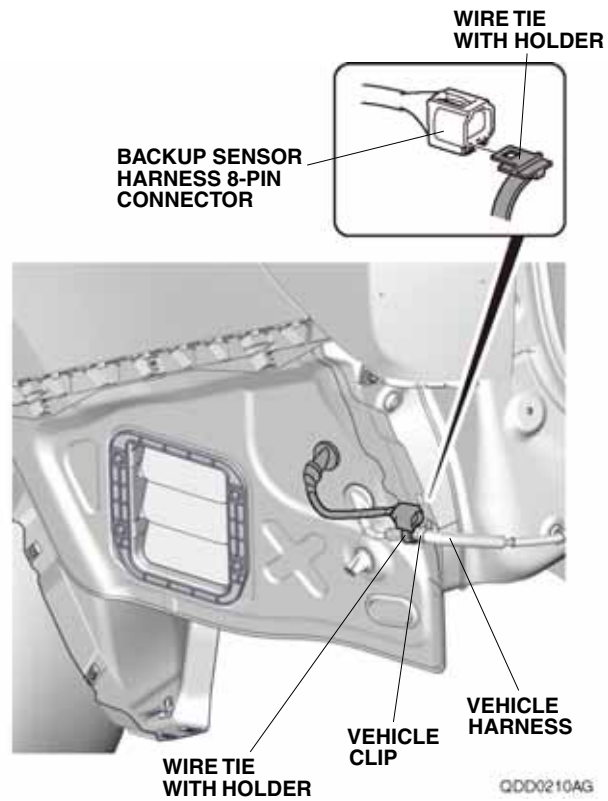

- Secure the backup sensor harness ground terminal to the vehicle using the vehicle ground bolt. Do not put the ground terminal calkings on top of one another.

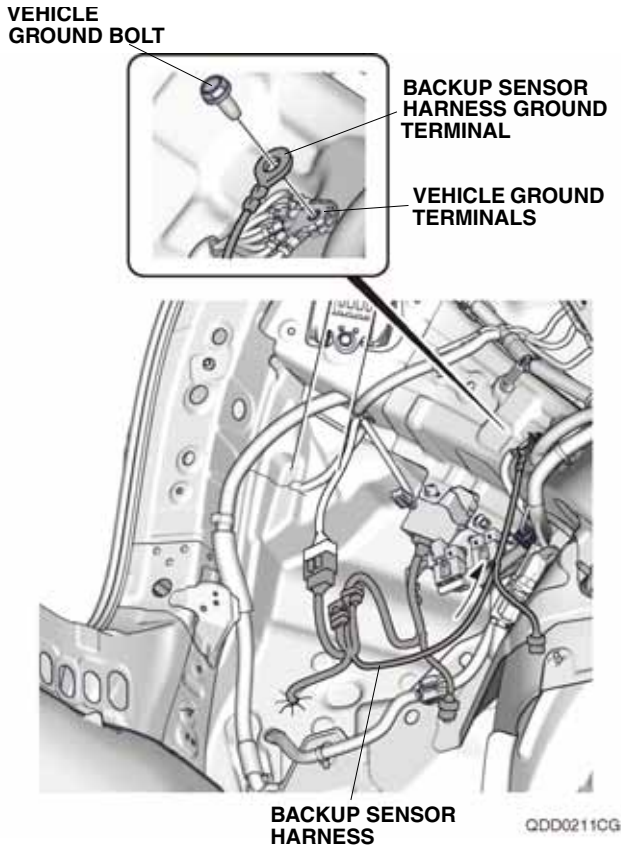

- Secure the backup sensor harness to the vehicle harness with four wire ties.

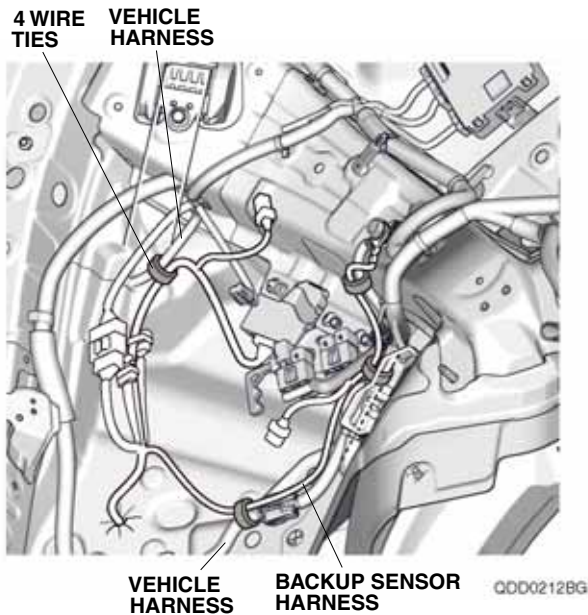

- Using isopropyl alcohol on a shop towel, thoroughly clean the vehicle panel where the buzzer will attach.

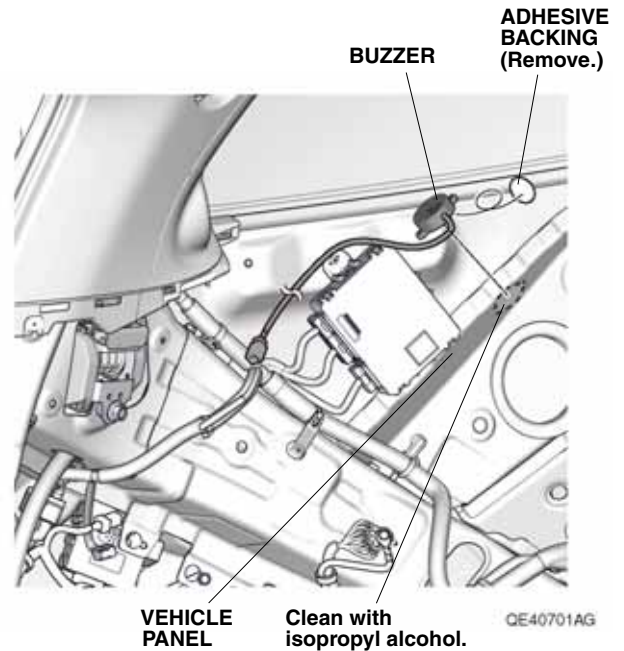

- Remove the adhesive backing from the buzzer and attach the buzzer to the vehicle panel in the location shown.

- Plug the backup sensor harness 2-pin connector into the buzzer 2-pin connector.

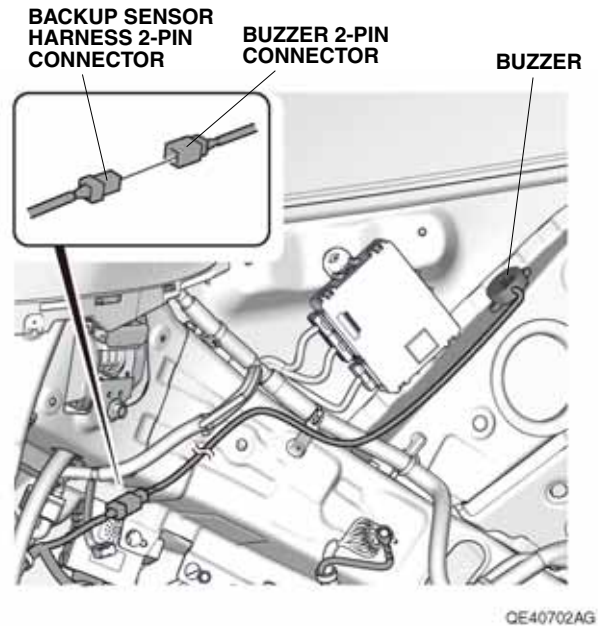

39. Bundle up the excess buzzer harness, and secure the buzzer harness and 2-pin connectors to the vehicle harness with three wire ties.

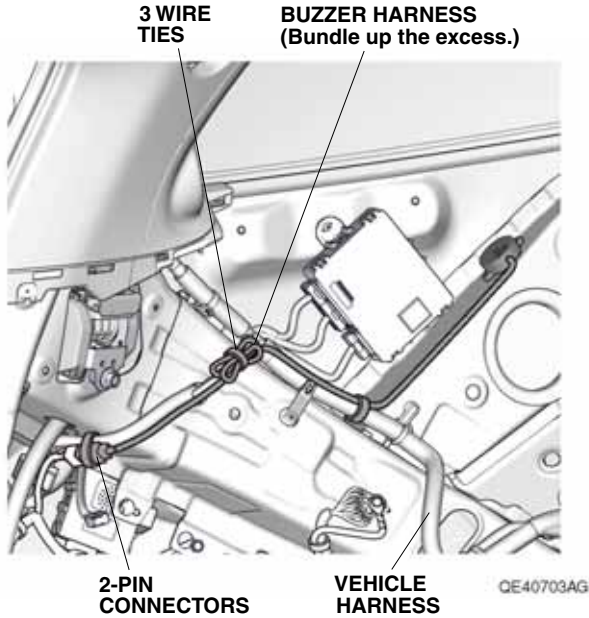

41. While wearing eye protection, drill the pierced mark on the left rear side trim panel with a 3 mm drill bit. Enlarge the 3 mm hole to 26 mm using a 26 mm hole saw. Remove any burrs.

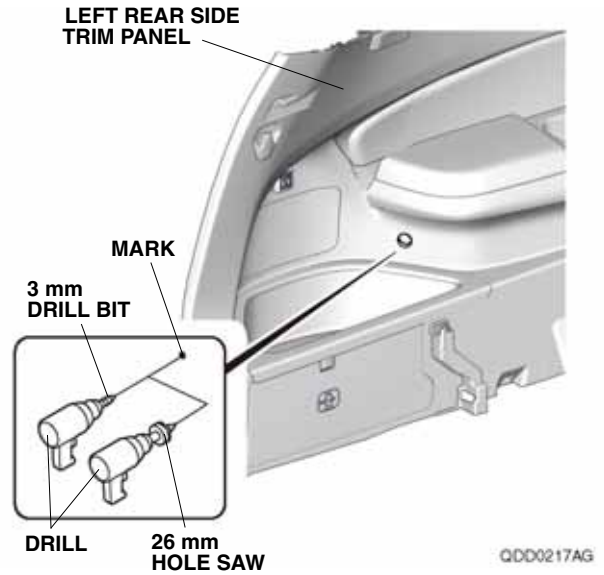

40. Using a pushpin, pierce the left rear side trim panel at the location shown.

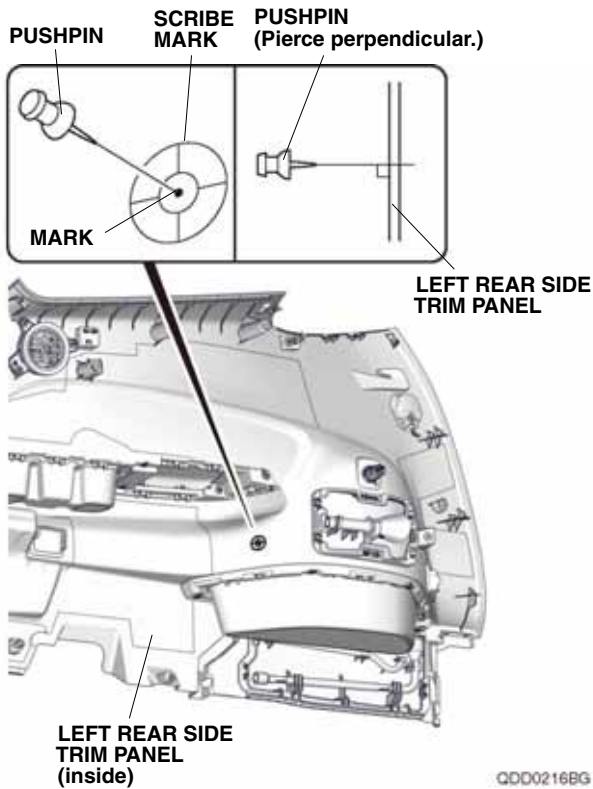

42. Install the switch into the 26 mm hole in the left rear side trim panel.
 NOTE: Make sure to install the switch in the correct orientation.

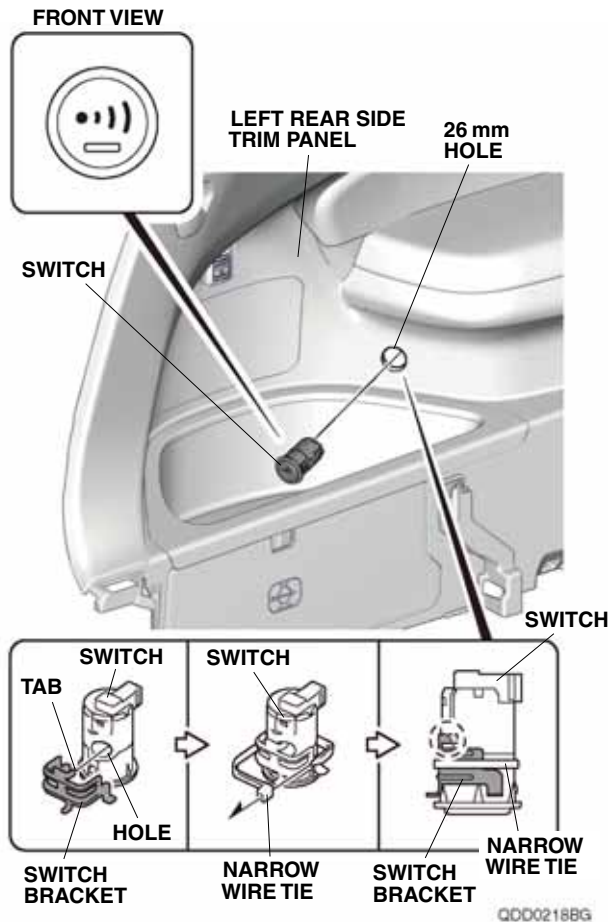

43. Align the tab on the switch bracket with the hole in the switch and secure the switch bracket to the switch with one narrow wire tie.
 NOTE: Firmly press the switch bracket against the left rear side trim panel, and make sure that there is no clearance between the switch and the trim panel.

If the vehicle is equipped with the trailer hitch harness, continue with step 44; otherwise, go to step 46.

With Trailer Hitch Harness

44. Position the left rear side trim panel and plug in the backup sensor harness 3-pin connector into the switch. Secure the 14-pin connectors to the left rear side trim panel.

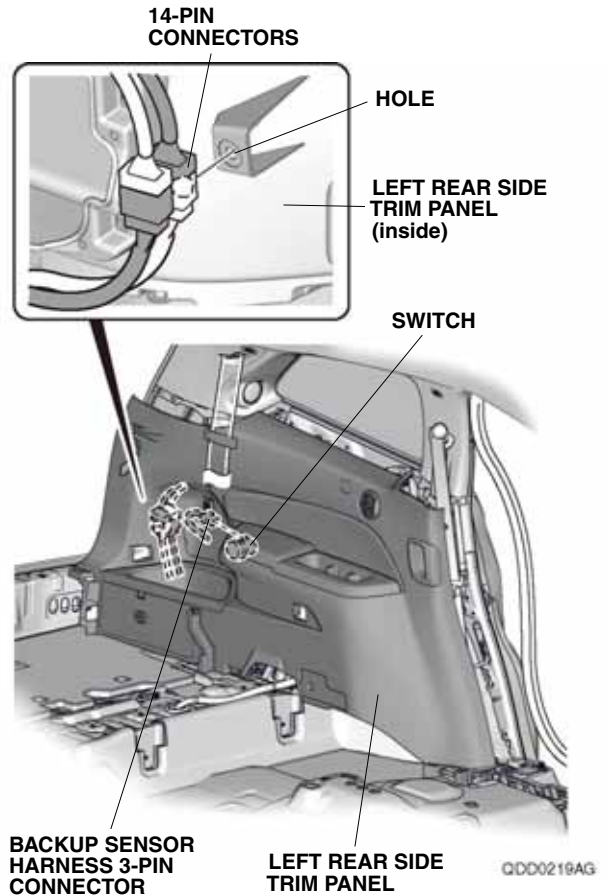

45. Reinstall the left rear side trim panel. Go to step 48.

Without Trailer Hitch Harness

46. Position the left rear side trim panel and plug in the backup sensor harness 3-pin connector into the switch. Secure the 14-pin connectors to the left rear side trim panel.

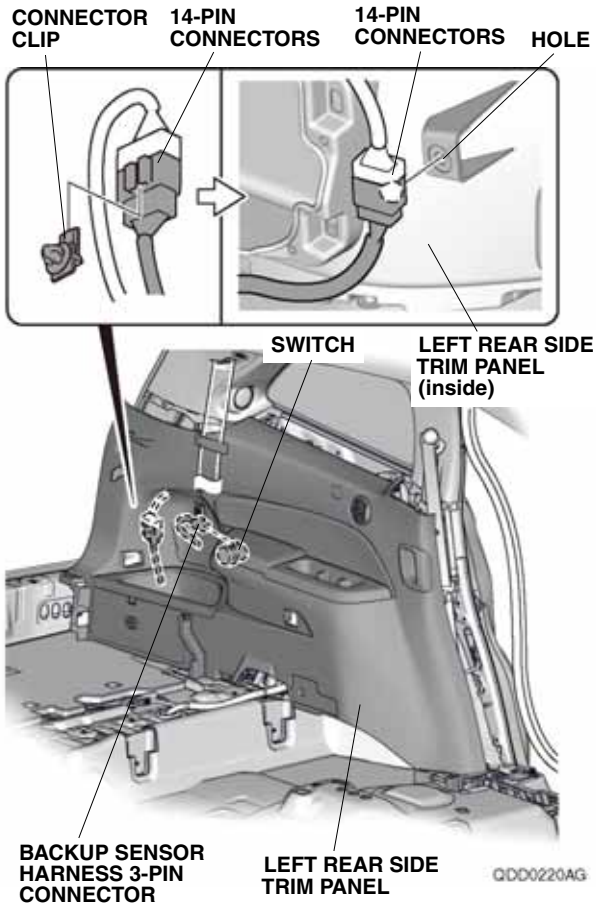

47. Reinstall the left rear side trim panel.

48. Remove the access panel.

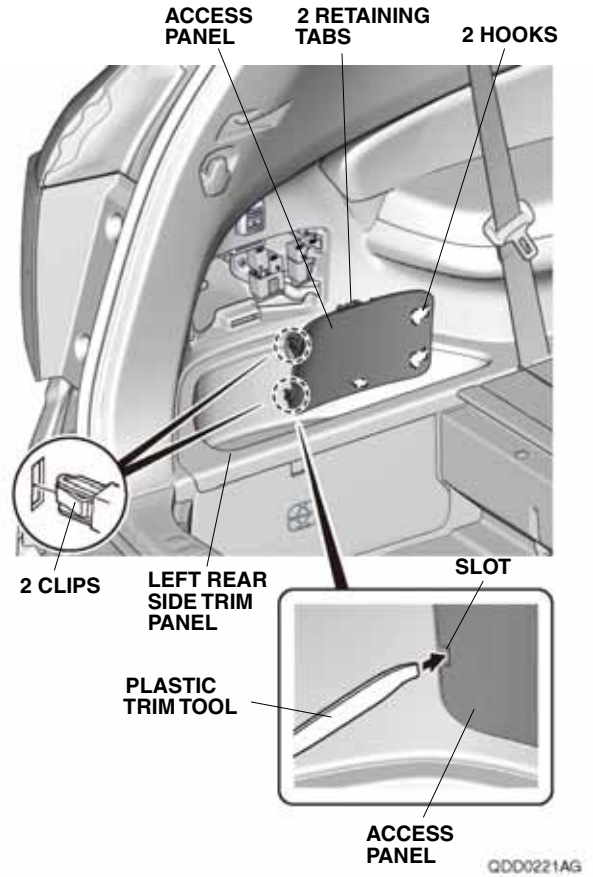

49. Secure the backup sensor harness to the left rear side trim panel with two narrow wire ties.

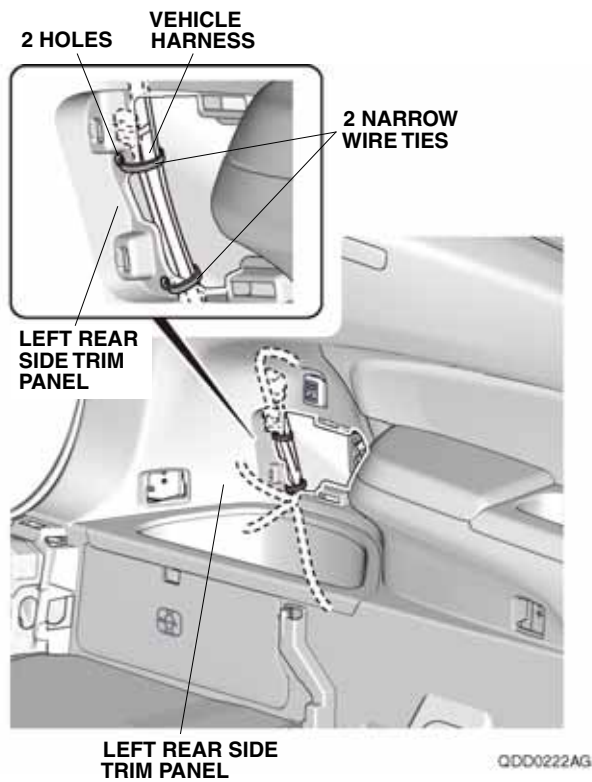

50. Mark the inside of the rear bumper:

- Locate the four scribe marks on the inside of the rear bumper at the left corner and right corner.
- Using a pushpin, pierce the left scribe mark of rear bumper at the top and center of the scribe mark.
- Using a pushpin, pierce the right scribe mark of rear bumper at the bottom and center of the scribe mark.

NOTE: There are several markings on the inside of the rear bumper. Before piercing the rear bumper, verify you have the correct locations.
NOTE: Make sure to pierce the scribe marks perpendicular to the rear bumper.

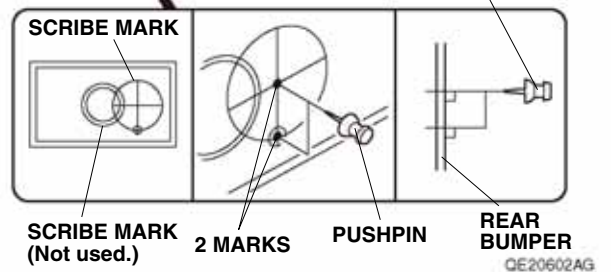
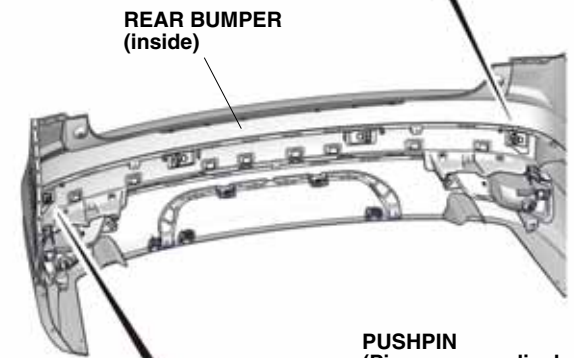
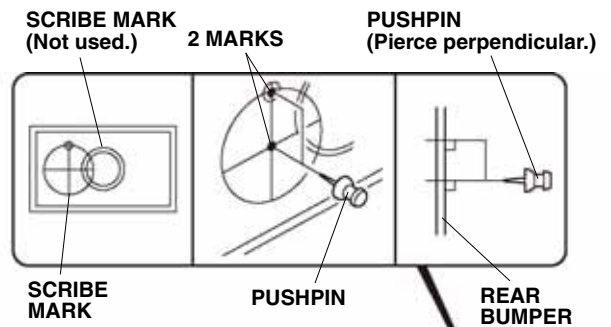

51. Mark the inside of the rear bumper:

- Locate the four scribe marks on the inside of the rear bumper at the left center and right center.
- Using a pushpin, pierce the rear bumper at the bottom and center of the two scribe marks.
NOTE: There are several markings on the inside of the rear bumper. Before piercing the rear bumper, verify you have the correct locations.
NOTE: Make sure to pierce the scribe marks perpendicular to the rear bumper.

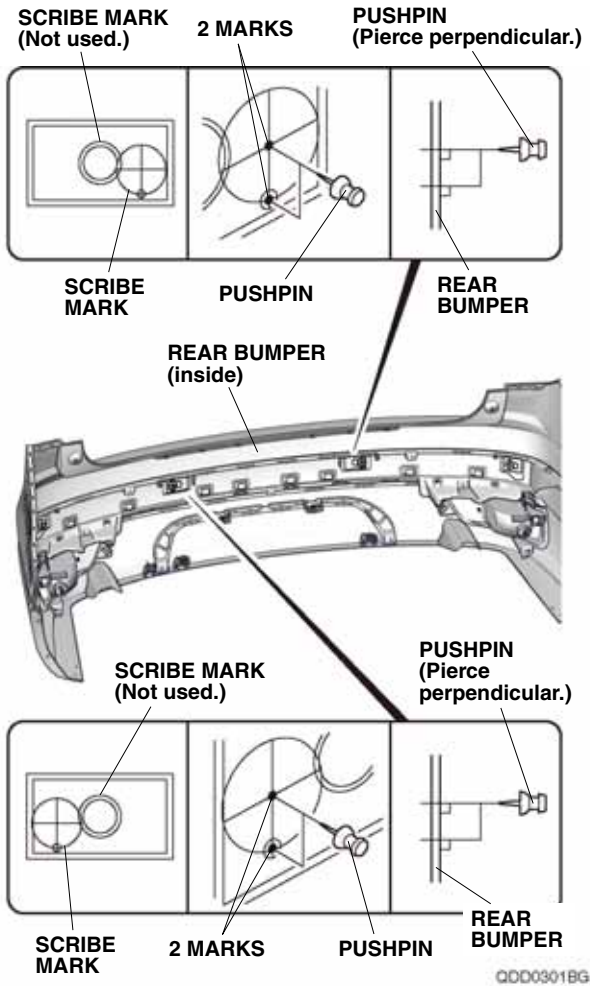

52. While wearing eye protection, drill the eight pierced marks with a 3 mm drill bit from the painted side of the rear bumper.
NOTE: Make sure to drill perpendicular to the rear bumper.

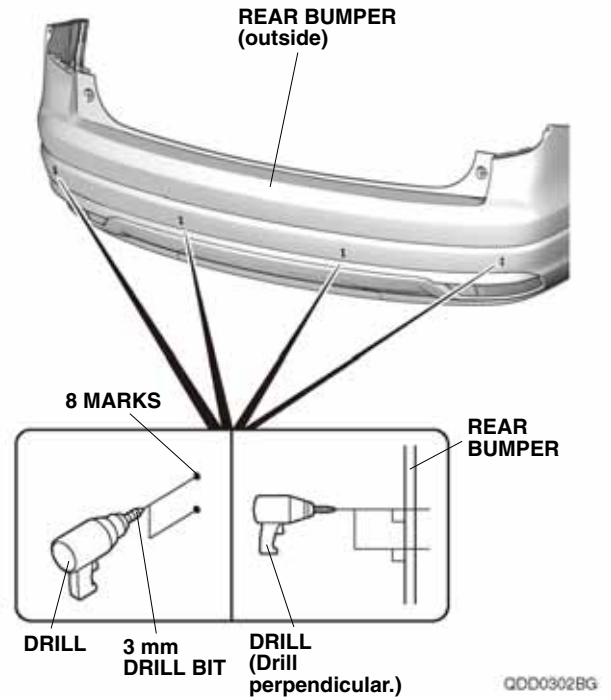

53. While wearing eye protection and drilling from painted side of the rear bumper, enlarge the left lower 3 mm outer hole and right upper 3 mm outer hole to 24 mm using a 24 mm hole saw.
 NOTE: Make sure to drill perpendicular to the rear bumper. Remove any burrs.

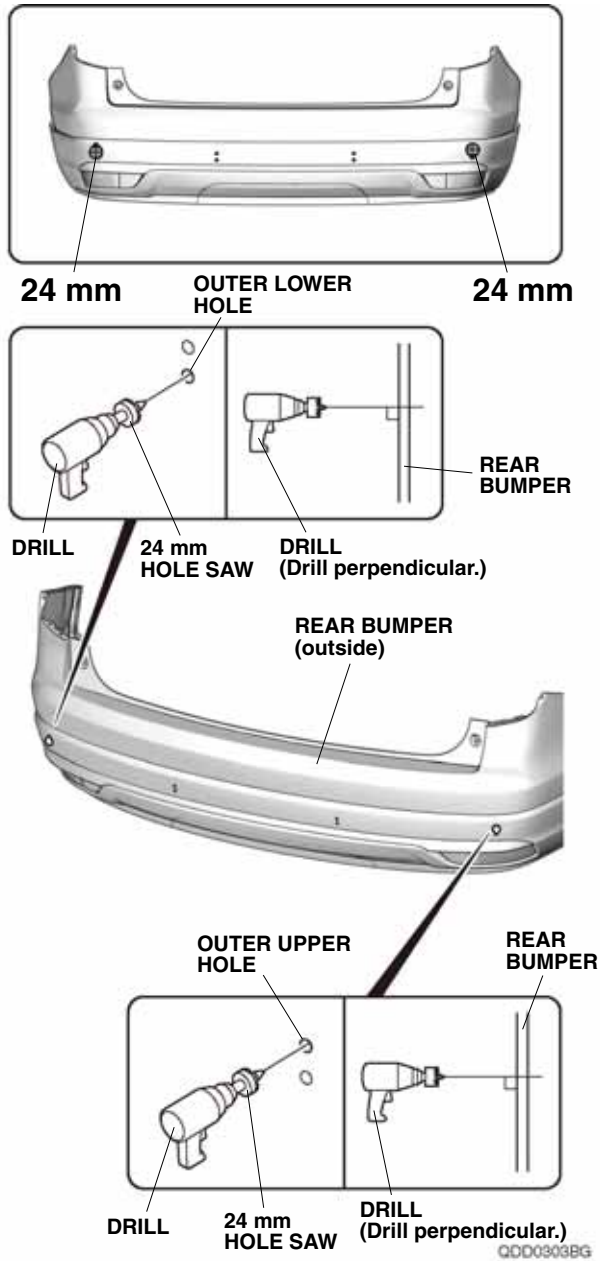

54. While wearing eye protection and drilling from painted side of the rear bumper, enlarge the two upper 3 mm inner holes to 26 mm using a 26 mm hole saw.
 NOTE: Make sure to drill perpendicular to the rear bumper. Remove any burrs.

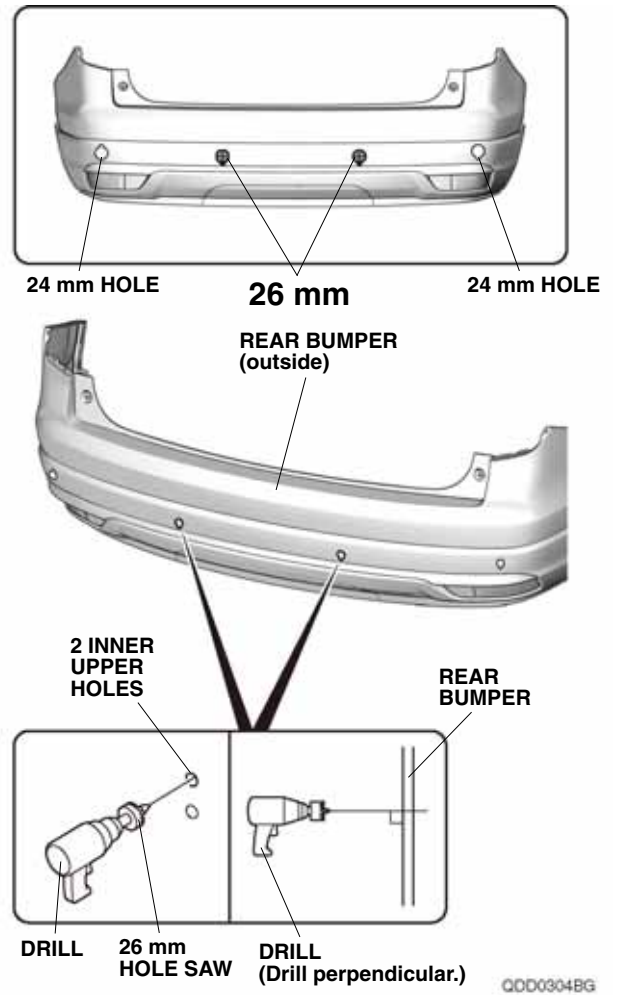

55. Insert the corner sensor (white) and left center sensor (blue) to the rear bumper.

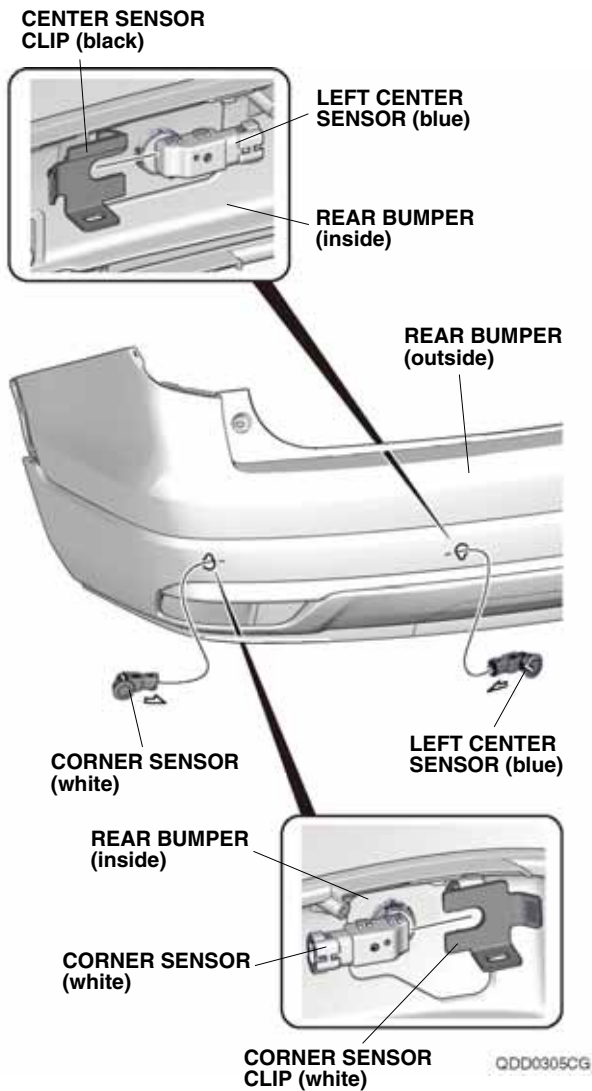

56. Secure the corner sensor (white) and left center sensor (blue) with corner sensor clip (white) and center sensor clip (black) as shown.

57. Insert the corner sensor (white) and right center sensor (blue) to the rear bumper.
NOTE: The right center sensor (blue) has a yellow dot label.

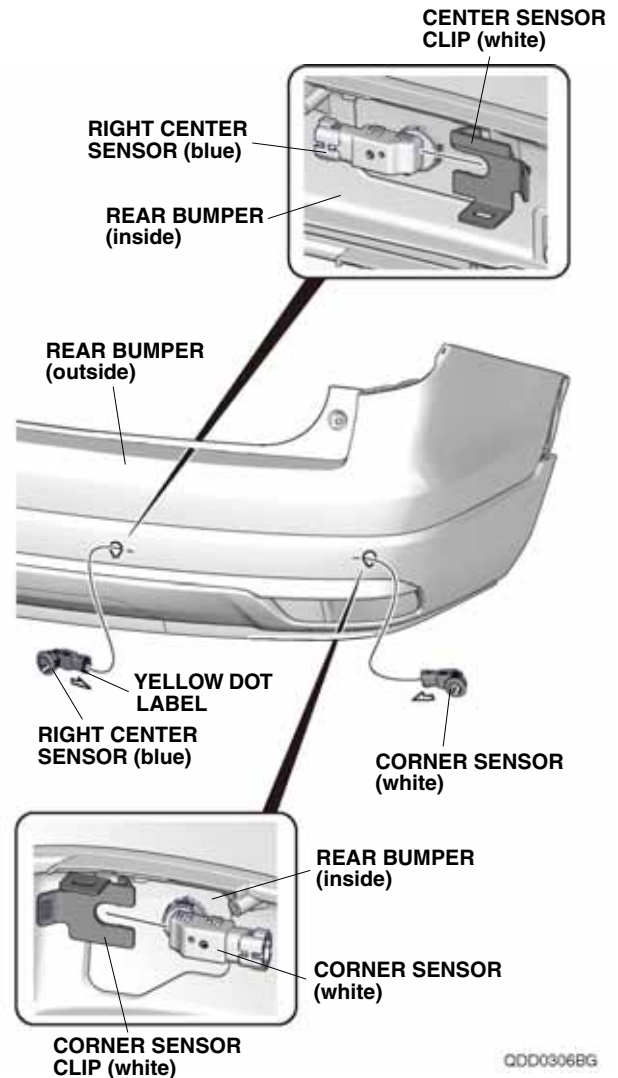

58. Secure the corner sensor (white) and right center sensor (blue) with corner sensor clip (white) and center sensor clip (white) as shown.

59. Plug the four subharness 2-pin connectors into the center sensors (blue) and corner sensors (white).

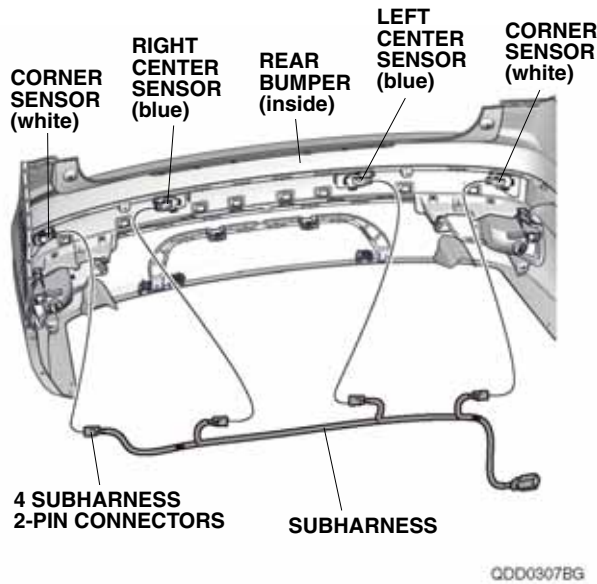

60. Align and secure the green tape on the subharness to the rear bumper as shown.

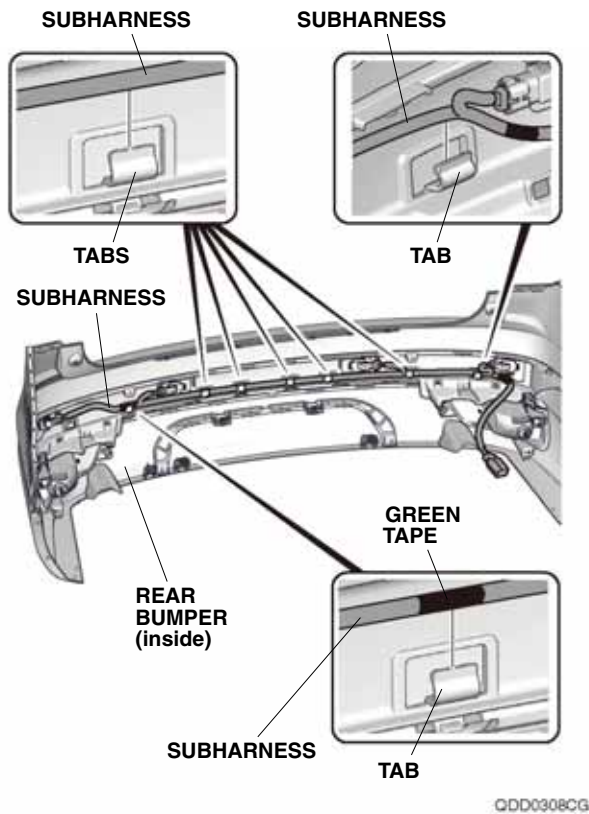

61. Using isopropyl alcohol on a shop towel, thoroughly clean the rear bumper where the aluminum tape will attach.

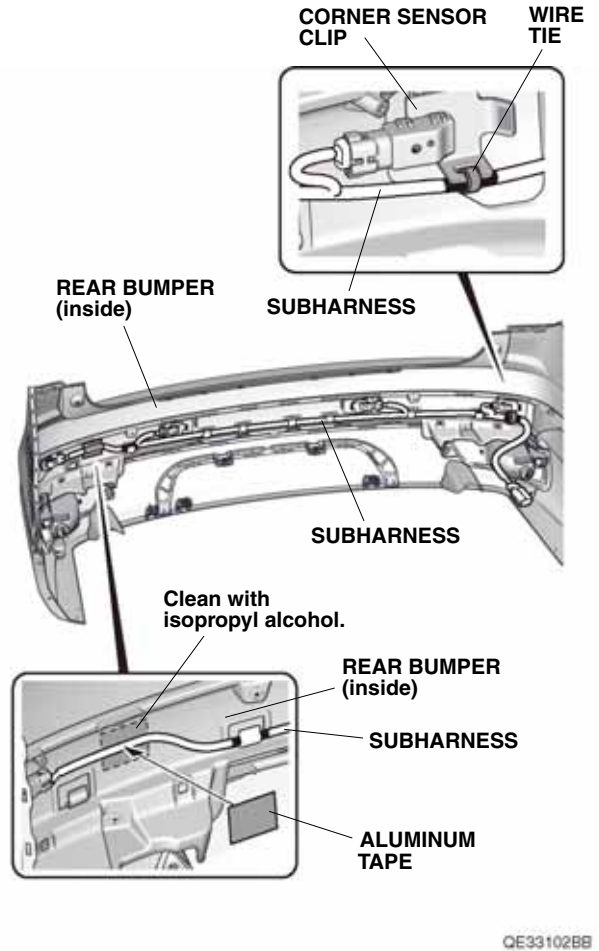

62. Secure the subharness to the rear bumper and corner sensor clip with one aluminum tape and one wire tie as shown.

63. With the help of an assistant, bring the rear bumper close to the vehicle, and plug the backup sensor harness 8-pin connector into the subharness 8-pin connector. Reinstall the rear bumper.

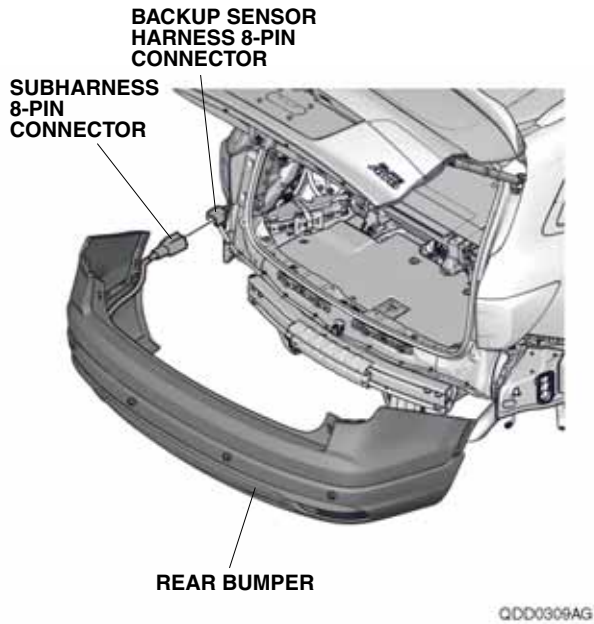

64. Check that all wire harnesses are routed properly and all connectors are plugged in.
65. Reinstall all removed parts except for the front bulkhead cover and the intake air tube.
66. Reconnect the negative cable to the battery.
67. Reinstall the front bulkhead cover and the intake air tube.
68. Press and hold the audio power button for two seconds to restore the audio and navi (if equipped) system functions.
69. Reset the clock on vehicle without navigation.

Check the Operation of the Backup Sensors

70. Check that the backup sensors work properly as described in the Accessory User's Information Manual supplied with the backup sensor kit.