



INSTALLATION INSTRUCTIONS

Accessory

ROOF BOX, SHORT
P/N 08L20-TA1-100

Application

CRUISER CROSSSTOUR

Publications No.

VERSION 1

Issue Date

AUG 2014

Put this information in the glove box with the vehicle owner's manual.

PARTS LIST

Roof box

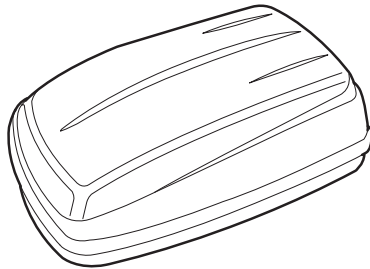

4 Brackets A

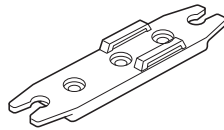

4 Brackets B

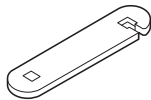

4 Plates

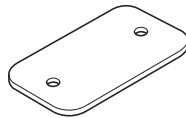

8 Knobs



8 Bolts



8 Washers



2 Straps



Seal

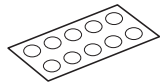

2 Keys



4 Large pads

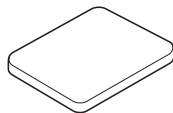

4 Small pads

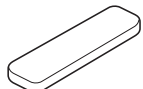

SUPPLIES REQUIRED

Isopropyl alcohol

Shop towel

INSTALLATION

NOTE:

- Be careful not to damage the roof and other finished surfaces of the body when installing the roof box.
- Optional roof rack crossbars (sold separately) are required to attach the roof box.

1. Open the roof box. Attach an adhesive seal over the unused mounting holes along the bottom of the box. The seals help prevent water from entering the roof box.

ROOF BOX

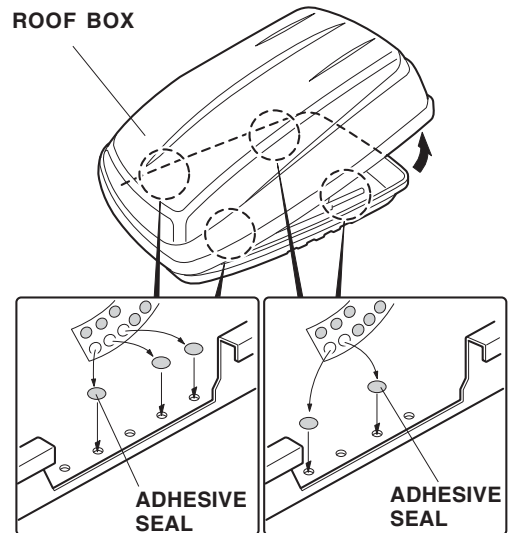

- Using isopropyl alcohol on a shop towel, clean four brackets B where the small pads will attach. Remove the backings from the small pads and attach them to the brackets B.

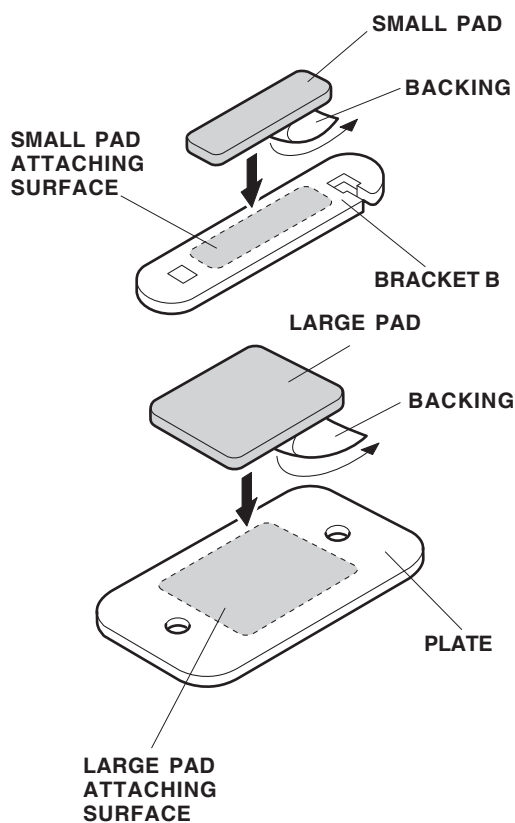

- Using isopropyl alcohol on a shop towel, clean four plates where the large pads will attach. Remove the backings from the large pads and attach them to the plates.

- Under the roof box, insert a bolt through bracket B, through the plate and into the predrilled hole in the bottom of the roof box.

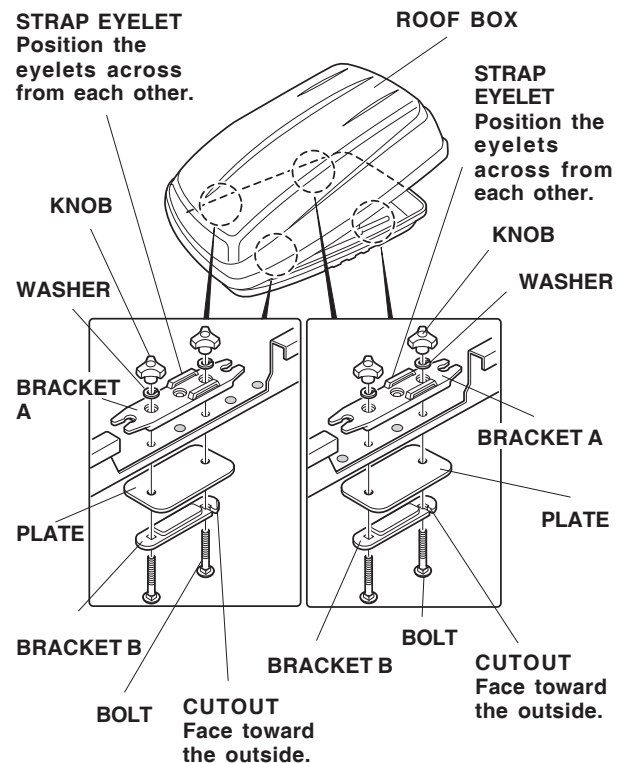

- Fit bracket A over the threads of the bolt where it goes through the roof box. Install a washer over the threads, and loosely install a knob. Install a second bolt the same way.
 - Install bracket A so that the right and left strap eyelet are positioned directly across from each other.
 - Install bracket B with the cutout facing the outside.
- Repeat steps 4 and 5 to install the brackets in the other three positions.

7. With the help of an assistant, carefully place the box on the crossbars so it is resting on the plates/pads. Be aware of the hardware hanging from the bottom of the box.

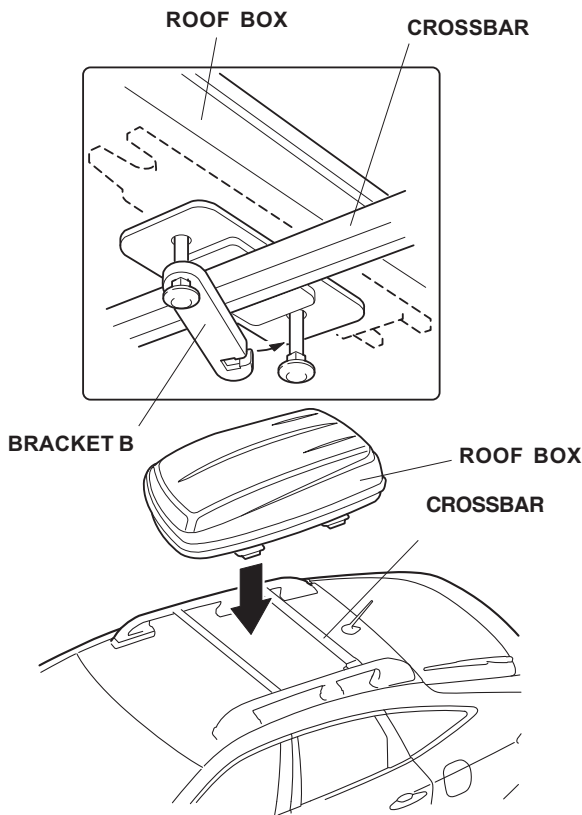

8. Swing the slotted end of bracket B around the bolt, and tighten the knobs. Fasten the box this way at all four mounting points.
- If necessary, adjust the distance between the crossbars to match the pattern of the predrilled holes in the roof box. The maximum possible distance between the crossbars should be used. Additional holes can be drilled in the bottom of the roof box without affecting its stability or load capacity. The minimum bar spread required is 21 5/8" for all racks.
 - The roof box should be centered on the crossbars and parallel to the direction of travel with its flat side facing the front.

9. Insert the straps through the eyelets on bracket A, and attach the straps together.

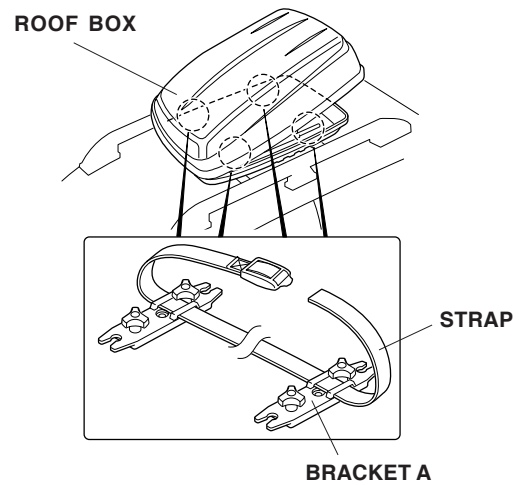

USE AND CARE

Unlocking/Locking the Roof Box

Unlocking: Insert the key into the lock and turn it counterclockwise to unlock. Press the center button to open the lid.

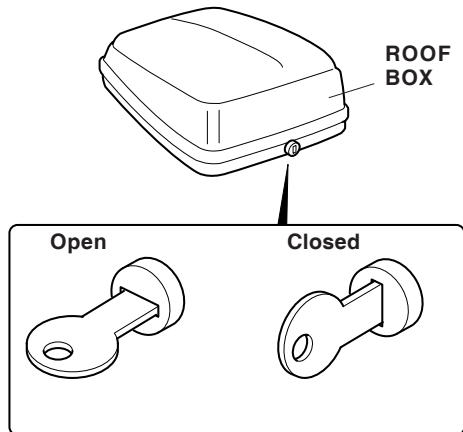

Locking: Press down on the lid. You should hear a click. Be sure the lid is latched by attempting to lift the lid. Turn the key clockwise to lock the roof box. Remove the key while not in use. Make sure the strap ends don't dangle from the roof box.

LOADING THE ROOF BOX

Load weight equally on both sides to minimize imbalance. Do not overload the roof box. The maximum allowable load is 100 lb (45 kg).

Loads must be secured to prevent them from sliding. Check the fasteners at regular intervals.