

PARTS LIST

Engine block heater

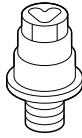

Aluminum washer



Heater harness

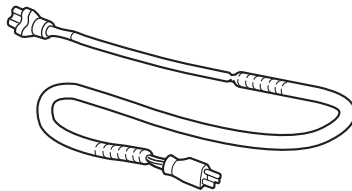

Protective cap

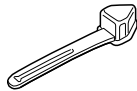

12 Black wire ties
 (2 not used)

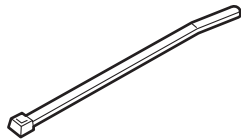

7 Wire tie with clips
 (6 Not used)

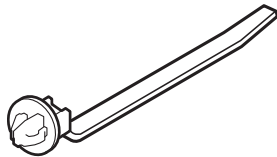

5 White wire ties
 (4 Not used)

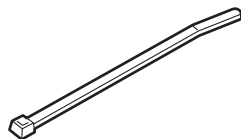

TOOLS AND SUPPLIES REQUIRED

- Ratchet
 - 10 mm, 19 mm, and 24 mm Sockets
 - Torque wrench
 - Diagonal cutters
 - Heavy gloves
 - Drain pan
 - Tape measure
 - White marker
 - Coolant (Honda All-Season Antifreeze/Coolant Type 2)
 - Fender cover
 - Blanket
- The following tool is available through the Honda Tool and Equipment Program. On the iN, click on: Service > Service Bay > Tool and Equipment Program, then enter the number under "Search." Or, call 888-424-6857.*
- Trim tool set (T/N SOJATP2014)

Illustration of the Engine Block Heater in the Vehicle

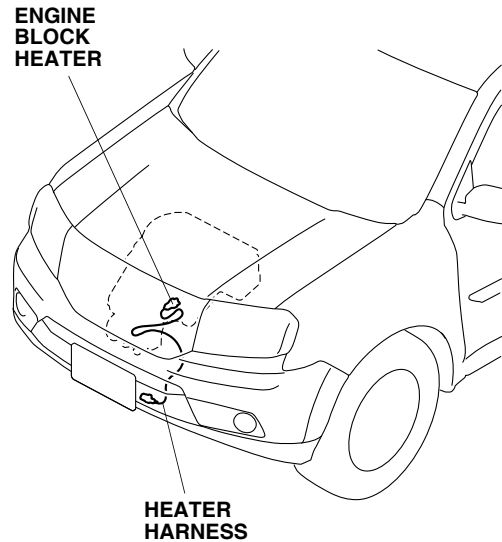

INSTALLATION

NOTE:

- Always use Honda All-Season Antifreeze/Coolant Type 2. Using a non-Honda coolant can result in corrosion, causing the cooling system to malfunction or fail.
- To avoid burning out the element, do not operate the engine block heater before it is installed in the vehicle and you have added coolant.

Customer Information: The information in this installation instruction is intended for use only by skilled technicians who have the proper tools, equipment, and training to correctly and safely add equipment to your vehicle. These procedures should not be attempted by “do-it-yourselfers.”

1. Allow the engine and all cooling system components to cool down.
2. Place a clean drain pan under the radiator drain plug, then remove the drain plug from the bottom of the radiator to drain the coolant. Remove the radiator cap to increase the flow.

NOTICE: Radiator coolant will damage paint. Quickly rinse any spilled coolant from painted surfaces.

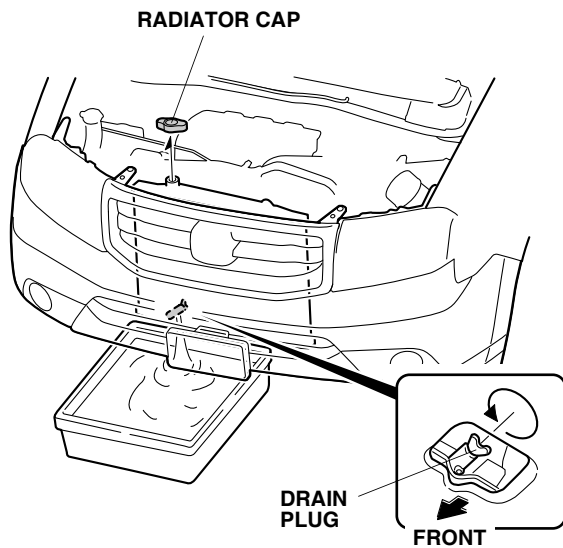

3. Remove the intake air box (two clips).

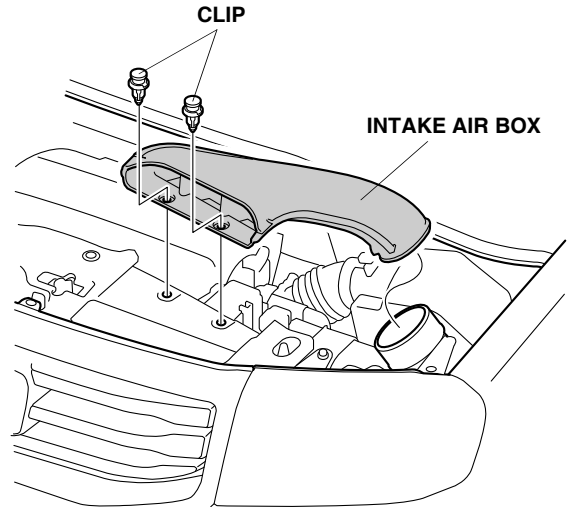

4. Remove the front bulkhead cover (seven clips).

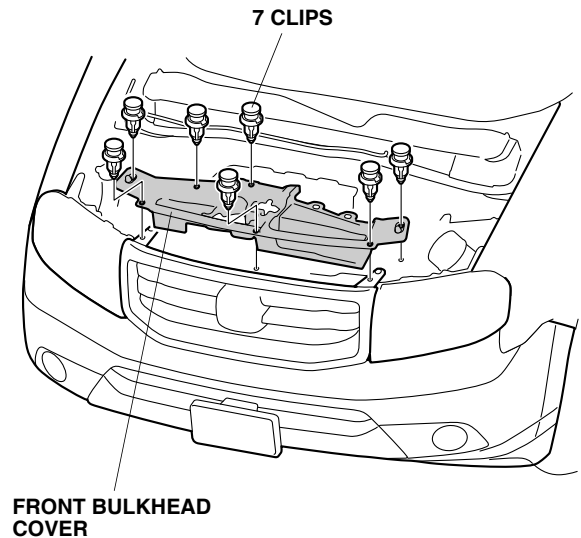

- Turn the two clips and remove the engine cover as shown.

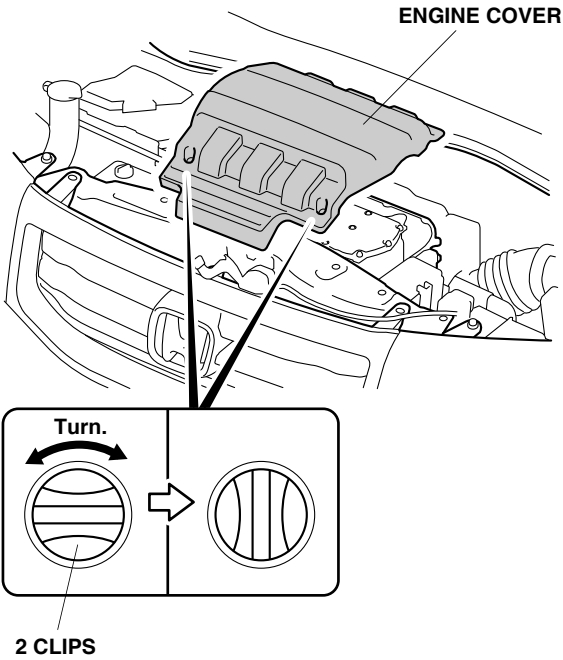

- With the help of an assistant, remove the front bumper (eight clips, three long clips, four self-tapping screws, two long self-tapping screws, four bolts, and two bolts). If the vehicle is equipped with fog lights or front parking sensors, unplug the vehicle connectors. Place the front bumper on a blanket after removal.

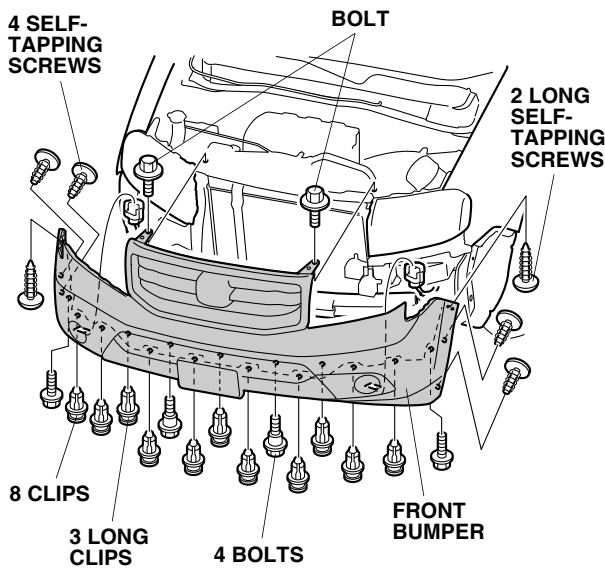

- Get the heater harness. Using a tape measure, install one wire tie with clip to the heater harness at the measurement shown.

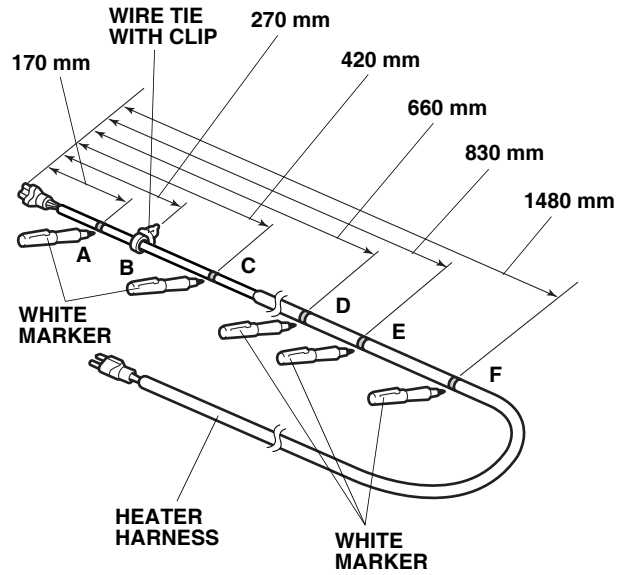

- Using a white marker, mark the heater harness at each measurement shown.

9. Locate and remove the engine block drain bolt and washer. Coolant remaining in the engine jackets will flow out of the bolt hole when the bolt is removed. (Retain the bolt in case the block heater is removed.)
NOTE: Use a new washer if the drain bolt is reinstalled.

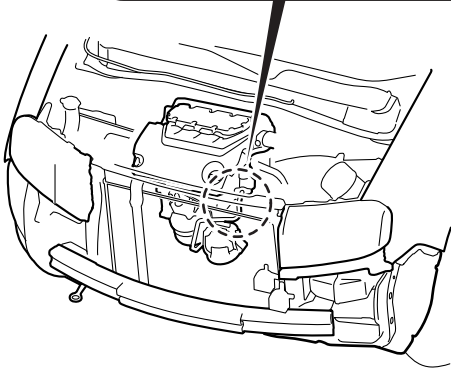
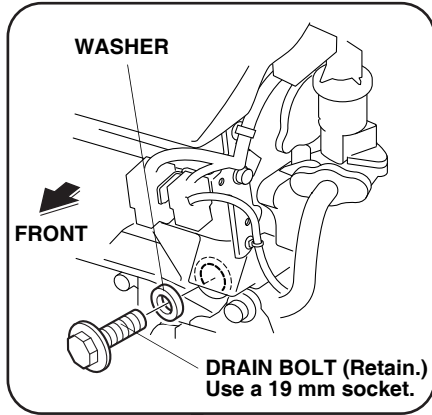

10. Install the engine block heater with the aluminum washer into the engine block using a 24 mm socket and a torque wrench. Torque the engine block heater to 60 N·m (44 lbf·ft).

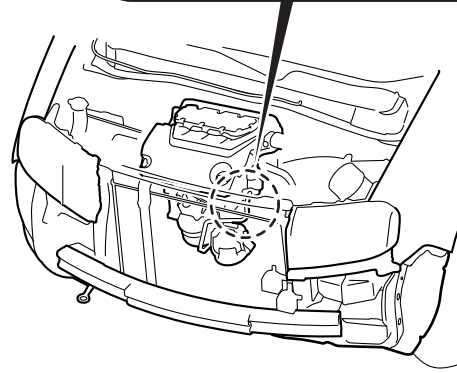
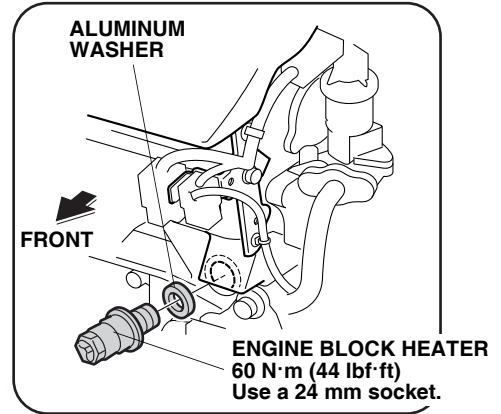

11. Plug the heater harness connector into the engine block heater.

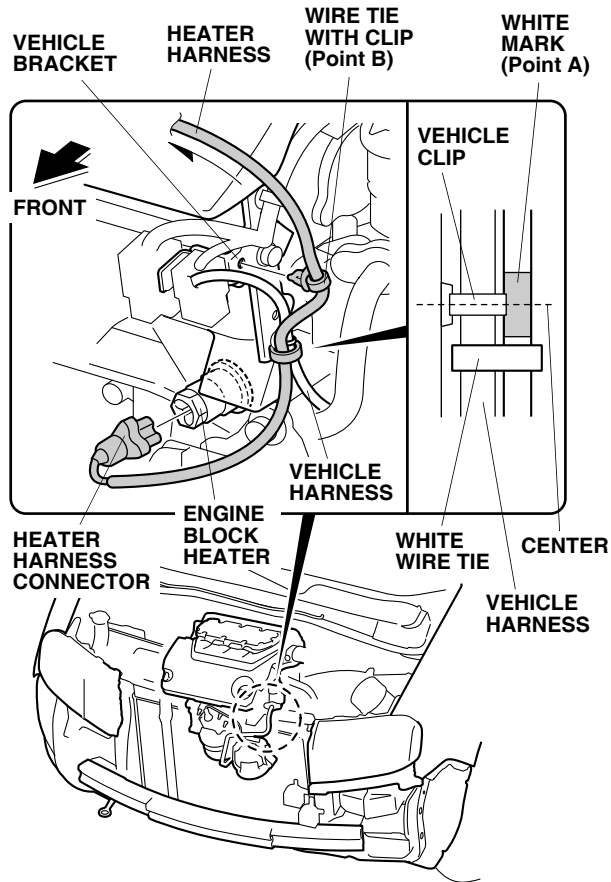

12. Route the heater harness up, and secure it to the vehicle harness with one white wire tie (Point A). Secure the heater harness to the vehicle bracket with one wire tie with clip (Point B).

13. Route the heater harness along the fan shroud, and secure it to the fan shroud rib with one black wire tie (Point C).

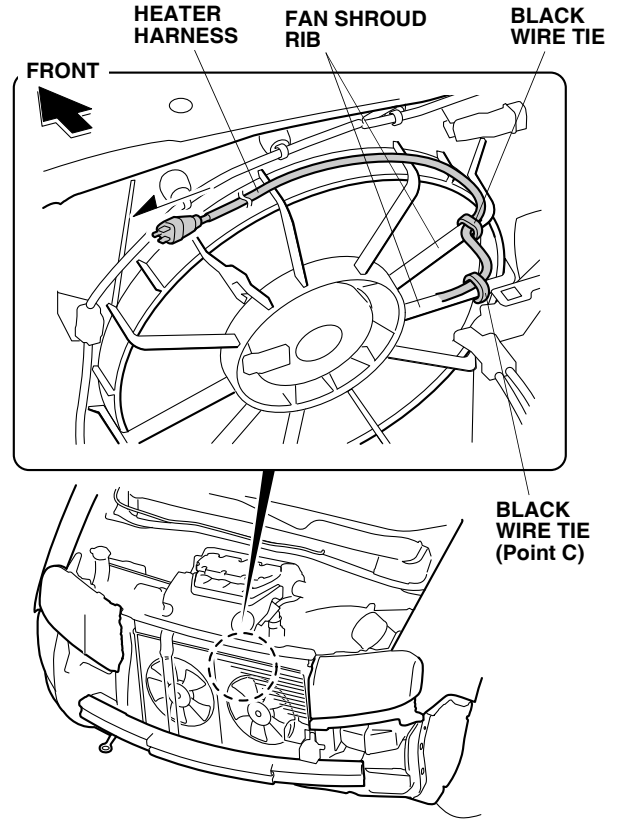

14. Secure the heater harness to the next fan shroud rib with one additional black wire tie.

- Route the heater harness over the fan shroud, and secure it to the vehicle harness with two black wire ties (Point D, E).

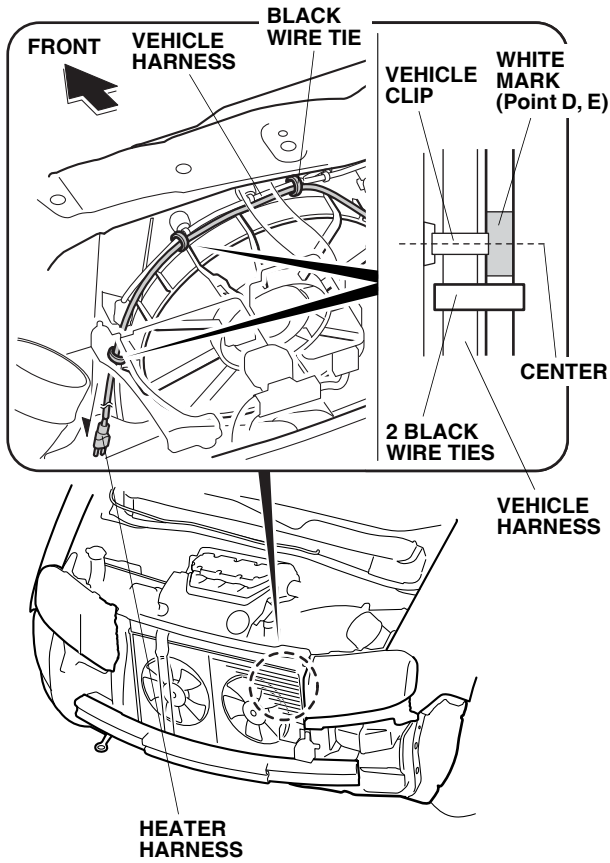

- Secure the heater harness to the vehicle harness with one additional black wire tie.
- Route the heater harness through the front bulkhead, and secure it to the vehicle harness with one black wire tie.

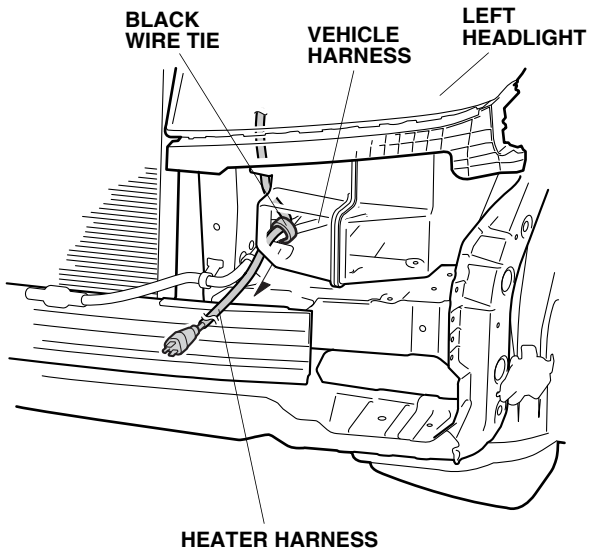

- Route the heater harness along the vehicle harness, and secure it to the vehicle harness with one black wire tie (Point F).

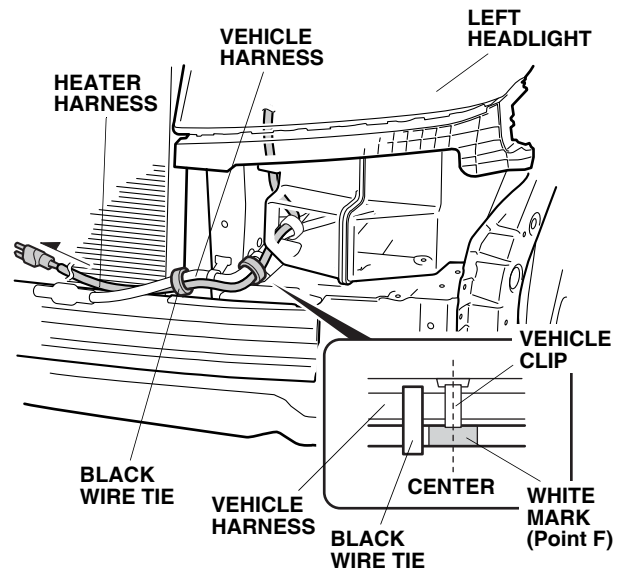

- Secure the heater harness to the vehicle harness with one additional black wire tie.

20. With the help of an assistant, reinstall the front bumper.

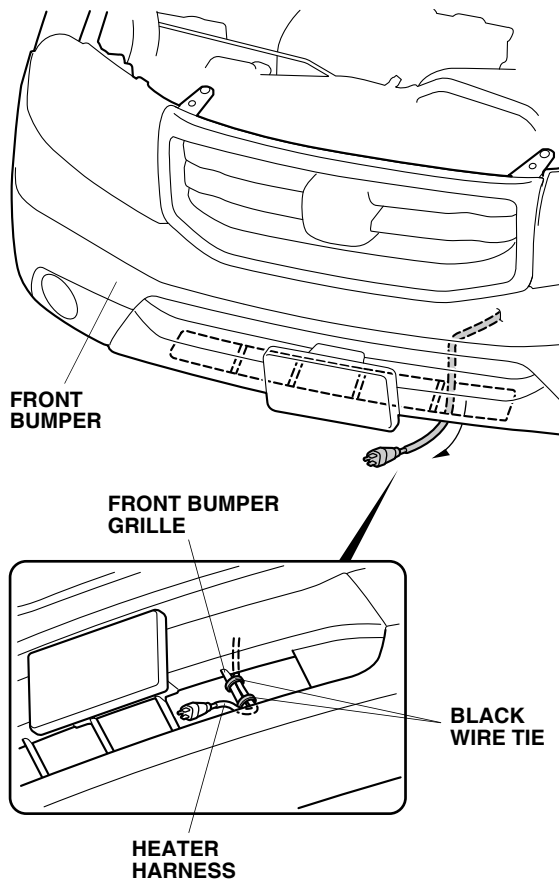

21. Route the heater harness through the front bumper, and secure it to the front bumper grille with two black wire ties.

22. Secure the protective cap to the front bumper grille, and install the heater harness connector into the protective cap.

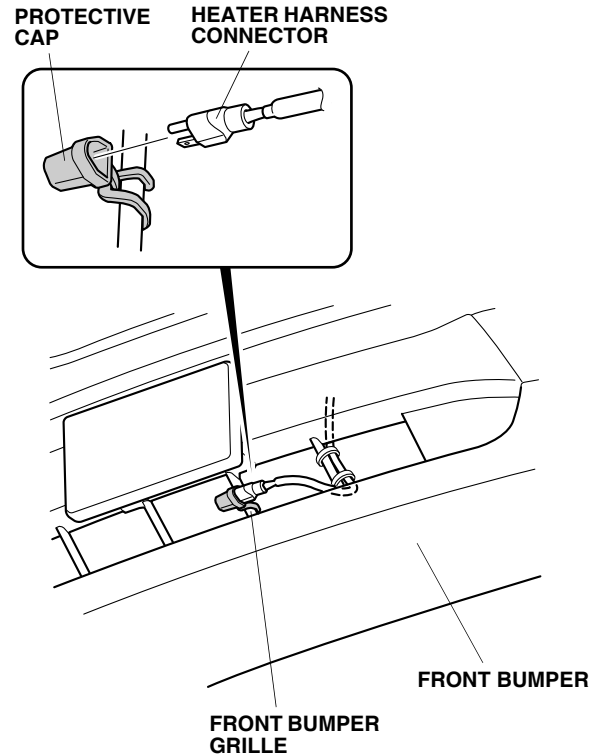

23. Reinstall the all removed parts.
24. Reinstall the radiator drain plug.
25. Fill the system with the recommended coolant. Follow the instructions in the service manual to fill and bleed the cooling system.
26. Check the coolant reservoir for correct level and check the cooling system for signs of leakage. Repair as necessary.
27. Check that the heater harness is routed properly and all connectors are plugged in.
28. Put the drain bolt (removed in step 9) in the glove box.
29. Enter the radio anti-theft code, and reset the radio station presets.
30. Reset the clock.