

**PARTS LIST**

**Remote Engine Starter Unit Kit  
P/N 08E91-E54-100**

Transmitter

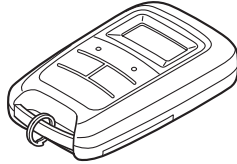

Control unit

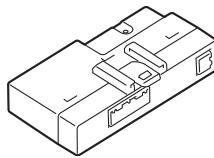

Antenna

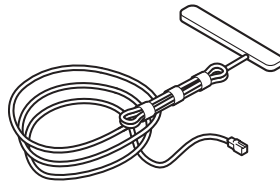

ID label

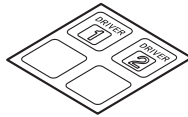

**Remote Control Engine Starter Attachment Kit  
P/N 08E92-T2A-100A  
(With Keyless Access System)**

Engine starter harness

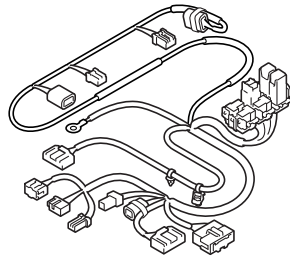

Control unit bracket

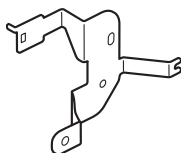

3 Relays

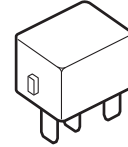

Flange nut



18 Wire ties

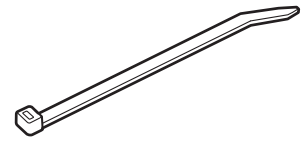

Wire tie with clip

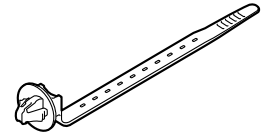

6 Urethane tapes

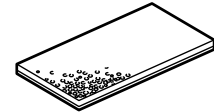

Clip

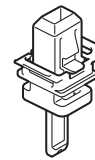

Caution label



Fuse label

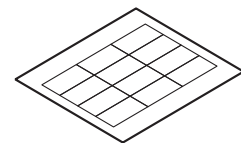

Accessory User's Information Manual

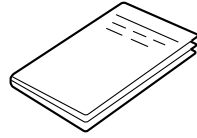

Quick Start Guide

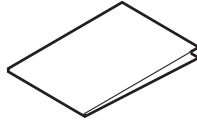

**Remote Control Engine Starter Attachment Kit  
P/N 08E92-T2A-100B  
(Without Keyless Access System)**

Engine starter harness

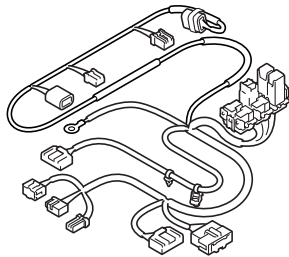

Control unit bracket

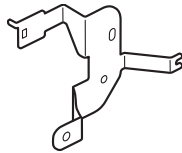

3 Relays

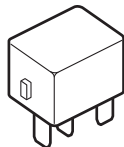

Flange nut



18 Wire ties

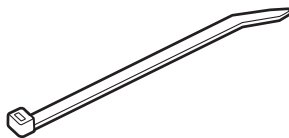

Wire tie with clip

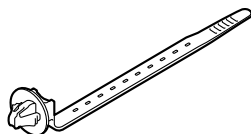

6 Urethane tapes

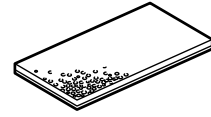

Clip

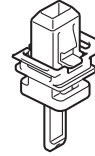

Caution label



Fuse label

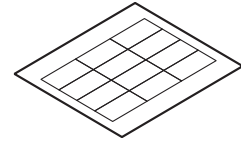

Accessory User's Information Manual

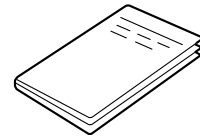

Quick Start Guide

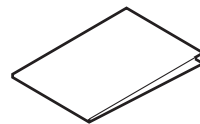

## TOOLS AND SUPPLIES REQUIRED

Flat-tip screwdriver  
Phillips screwdriver  
Ratchet  
10 mm Socket  
10 mm Open end wrench  
Isopropyl alcohol  
Shop towel  
Tape measure  
Scissors  
HDS/MVCI  
Masking tape  
Diagonal cutters  
Ruler  
Tape  
Utility knife

*The following tools are available through the Honda Tool and Equipment Program. On the iN, click on: Service > Service Bay > Tool and Equipment Program, then enter the number under "Search". Or, call 888-424-6857.*

- Trim Tool Set (T/N SOJATP2014)
- Plastic Trim Tool (T/N SILTRIMTL10)

### **Illustration of the Remote Control Engine Starter in the Vehicle**

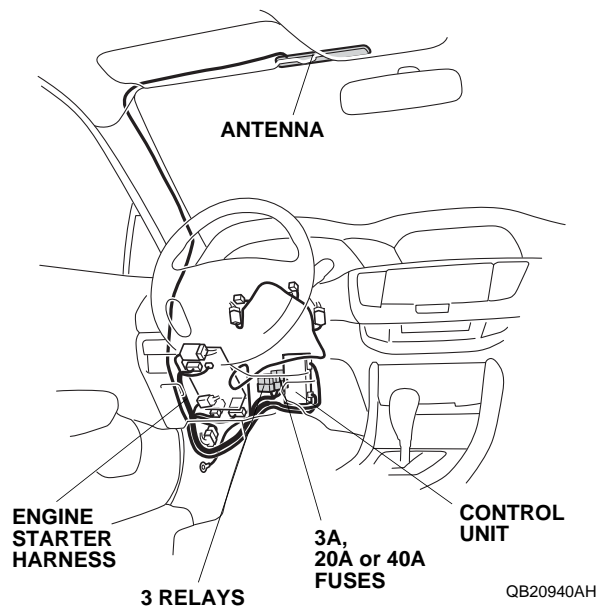

## INSTALLATION

**Customer Information:** The information in this installation instruction is intended for use only by skilled technicians who have the proper tools, equipment, and training to correctly and safely add equipment to your vehicle. These procedures should not be attempted by "do-it-yourselfers."

1. Disconnect the negative cable from the battery.
2. Attach the ID label.
  - Using isopropyl alcohol on a shop towel, clean the area where the ID label will attach.
  - Attach the ID label to the transmitter in the area as shown.

### With Keyless Memory Settings

NOTE: The remote is factory set for driver 1 remote control. To program the driver 2 remote, follow the "REMOTE CONTROL ENGINE STARTER TRANSMITTER REGISTRATION" instructions on ISIS.

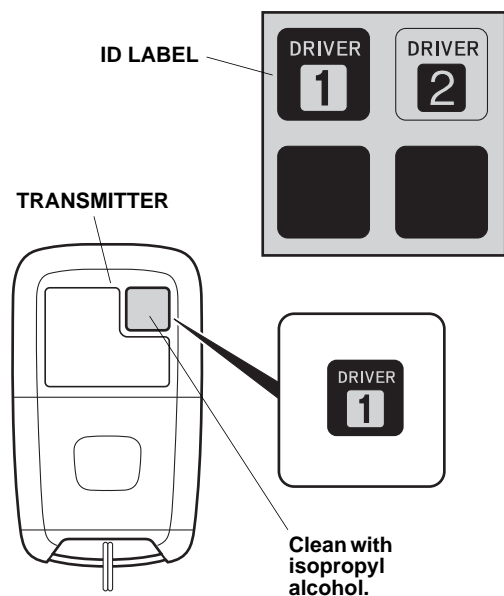

QB20939DH

## Without Keyless Memory Settings

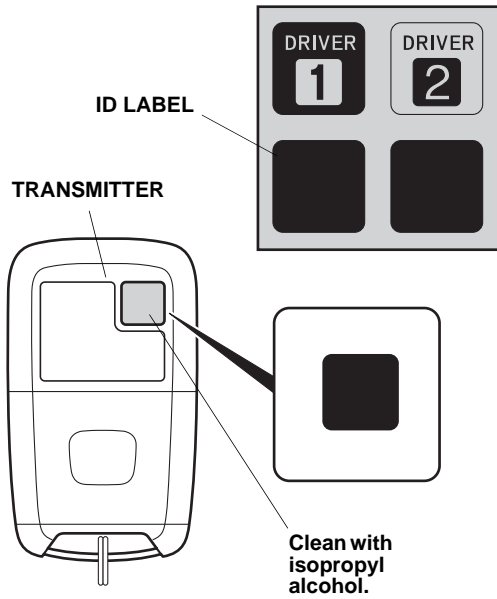

QB32111CH

3. If equipped, remove the roof console.
  - Using a plastic trim tool, pry out and remove the left and right lenses (four retaining tabs each).
  - Open the sunglass holder. Remove four screws.
  - Remove the roof console (unplug the vehicle connectors).

## With Moonroof

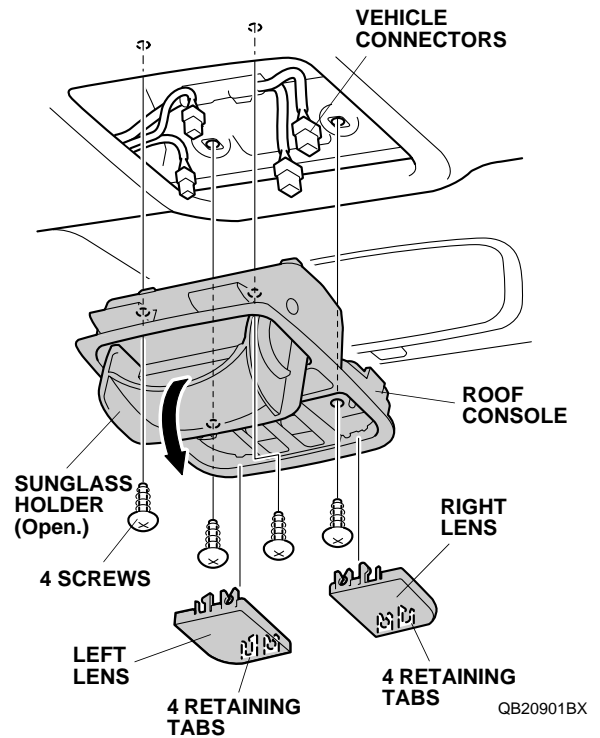

Without Moonroof

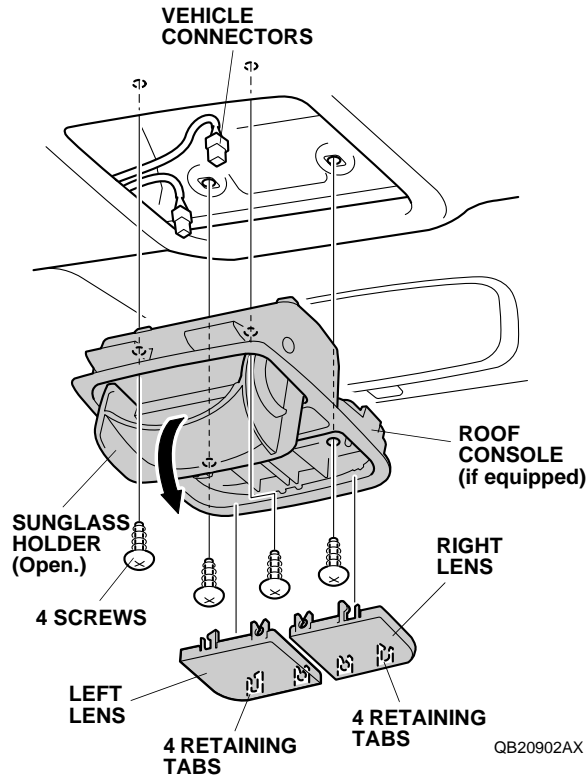

- Remove two sunvisor holders by rotating them 90° counterclockwise.

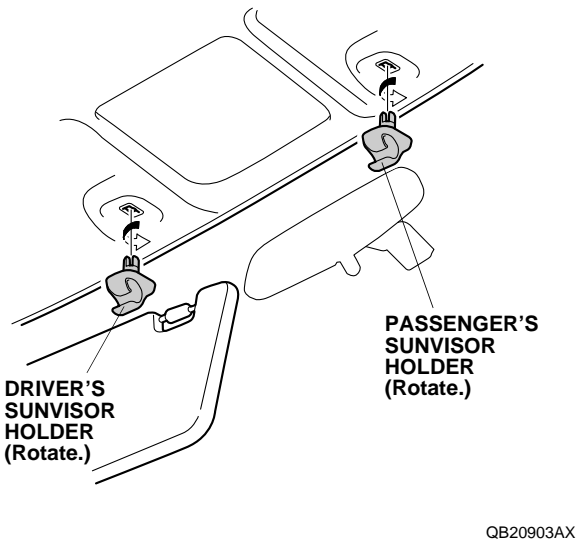

- Wrap the end of a flat-tip screwdriver with tape. Locate the slot in the bracket cover, and insert the flat-tip screwdriver into the slot. Push the hook with the screwdriver.

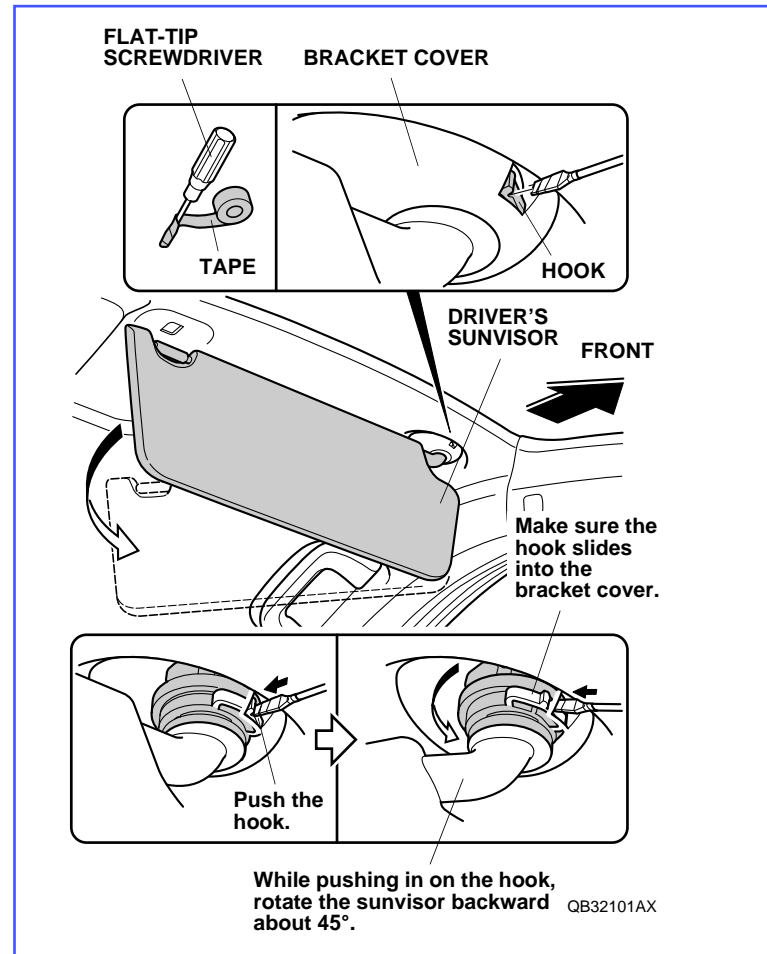

- While pushing in on the hook, rotate the driver's sunvisor backward about 45°. Make sure the hook slides into the bracket cover. NOTE: If the hook did not stay pushed in, return the driver's sunvisor to its original position and repeat steps 5 and 6.

- Remove the driver's sunvisor (unplug the vehicle connector).

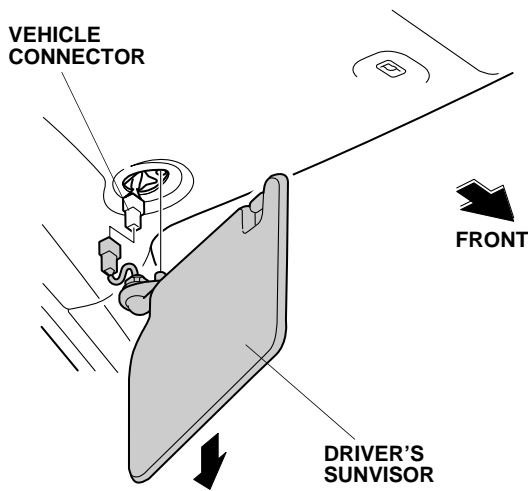

QB20904AX

- Pull away the driver's door opening seal in the area shown.

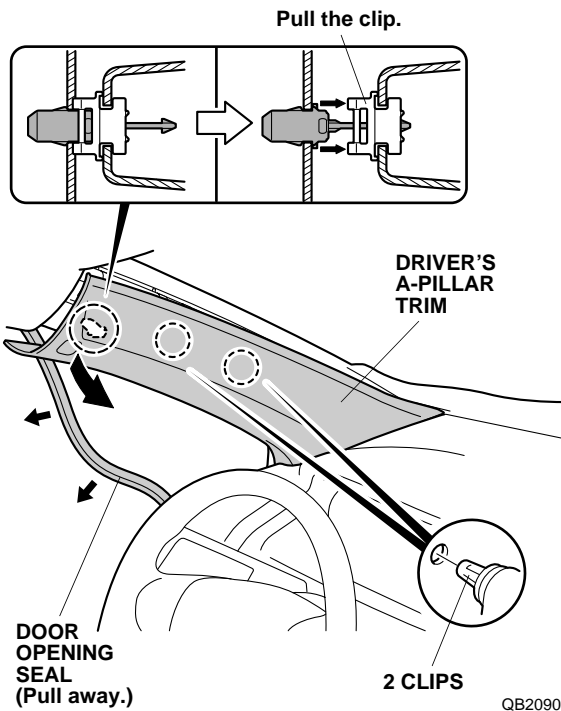

QB20905AX

- Pull out on the driver's A-pillar trim to release the clips.

- Insert a shop towel in the opening between the driver's A-pillar trim and the dashboard to prevent dropping the A-pillar clips. Take care not to damage the driver's A-pillar trim.

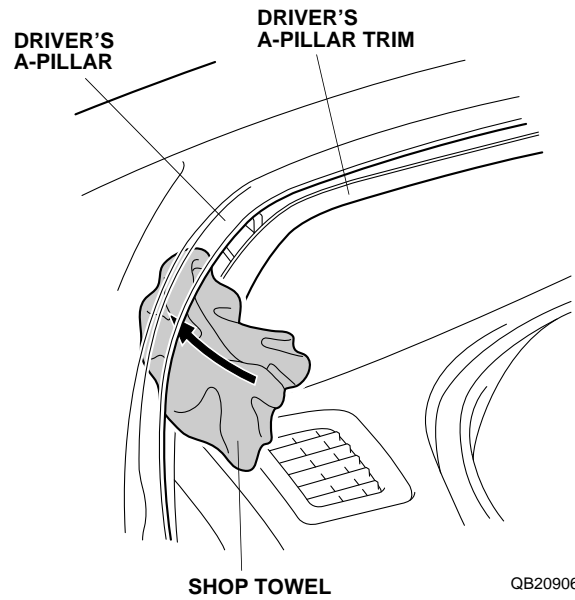

QB20906AX

- Slide up the driver's A-pillar trim to remove it from the upper clip. Carefully remove the shop towel and any clips that fell from the driver's A-pillar trim. **NOTE:** The upper clip will stay in the body.

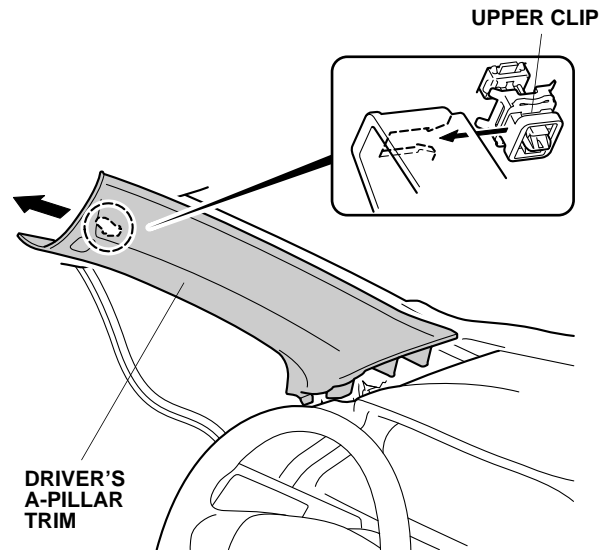

QB20907AX

- Remove the remaining upper clip from the driver's A-pillar.

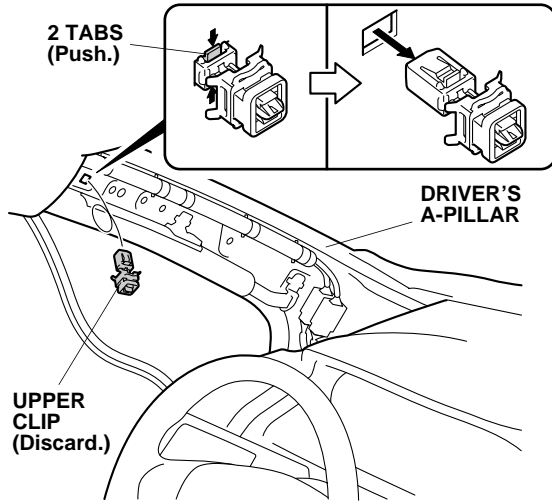

QB20908AX

- Install the new clip (supplied) to the driver's A-pillar trim, but do not reinstall the trim at this time.

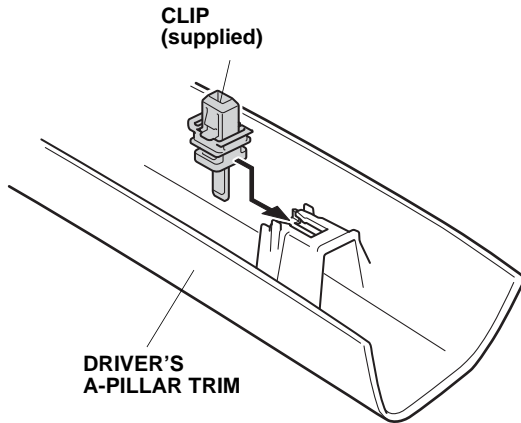

Q0N0533AH

- If equipped, remove the driver's dashboard under cover (turn the knob and two clips).

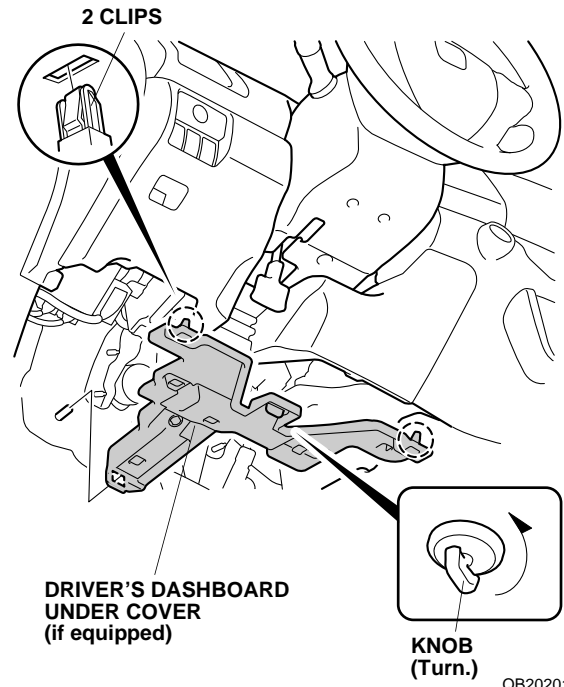

QB20201AB

- Remove the driver's dashboard lower cover (nine clips and unplug the vehicle connectors, if equipped).

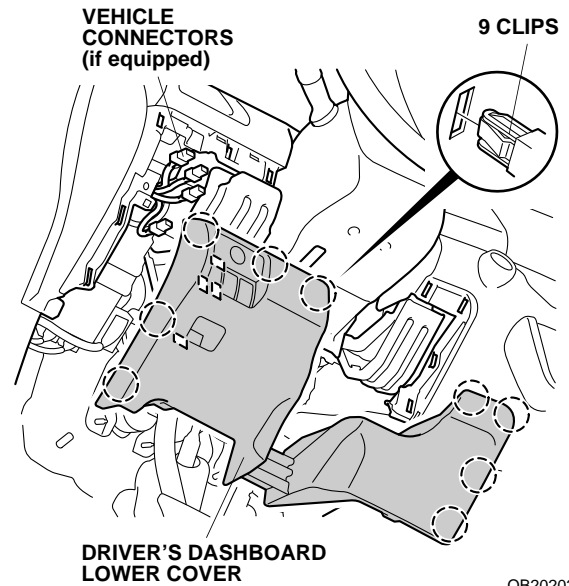

QB20202BB

16. Remove the cover (six retaining tabs). Using the ignition key, unlock the trunk lid/fuel fill door opener, then remove the key.

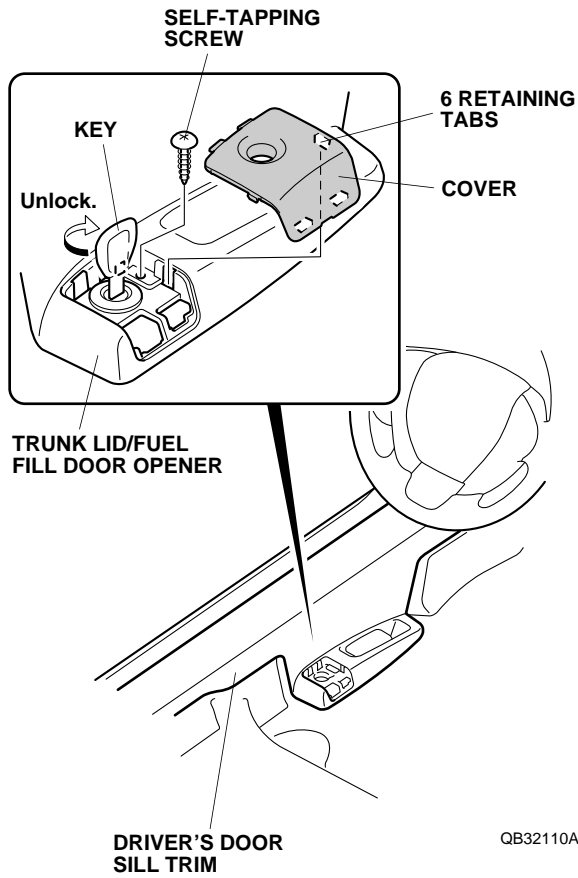

17. Remove one self-tapping screw from the trunk lid/fuel fill door opener cover.

18. Remove the driver's door sill trim.

4-Door: Two retaining tabs and four clips.

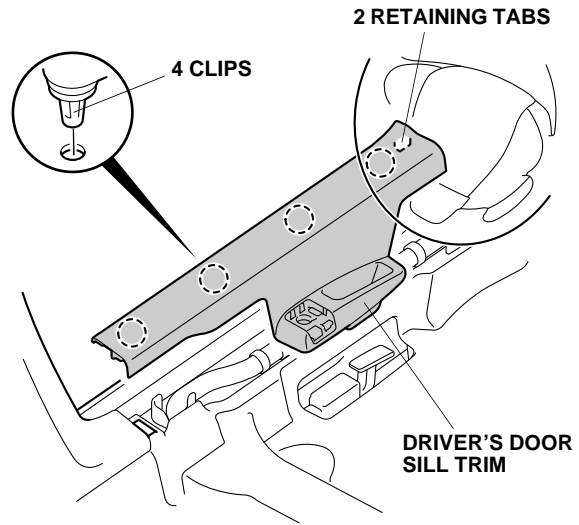

2-Door: Two retaining tabs and six clips.

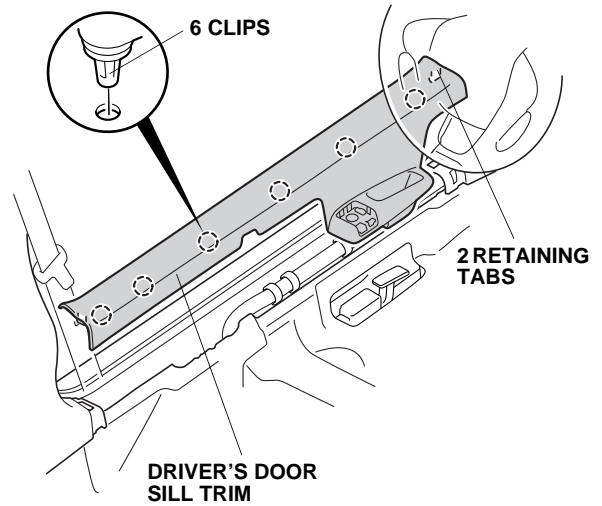



19. Pull away the door opening seal, and remove the driver's kick panel (two clips).

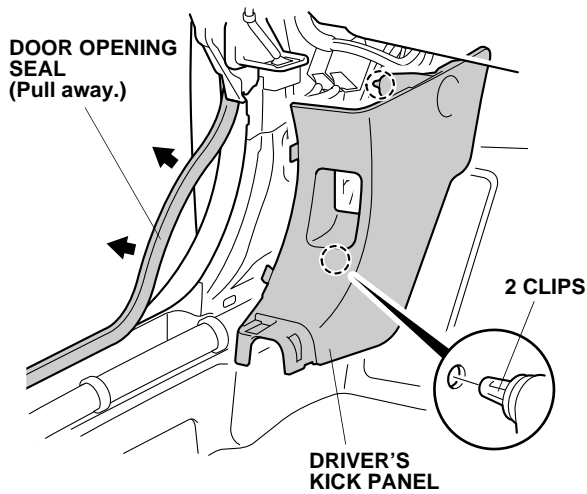

QB20805AB

20. Lower the tilt lever, and release the column band (two clips). If the vehicle is equipped with keyless access system, reconnect the negative cable to the battery, then press the engine start/stop button to select the ON mode.

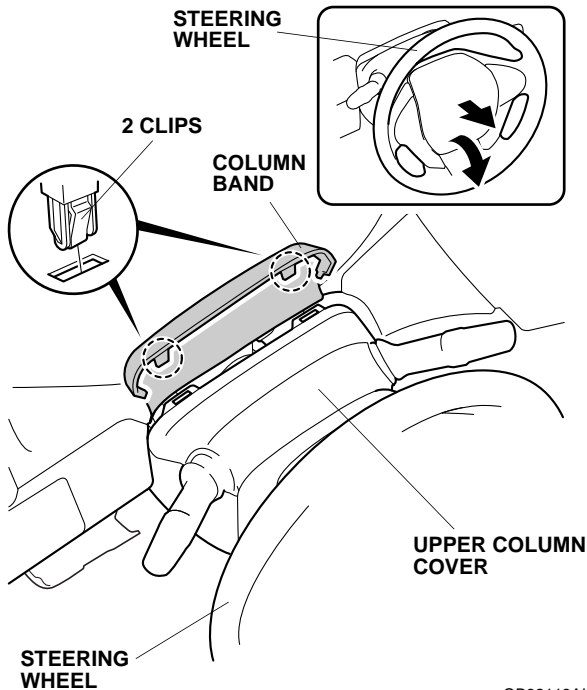

QB32113AH

21. Turn the steering wheel 90° clockwise. Using a plastic trim tool, release the retaining tab.

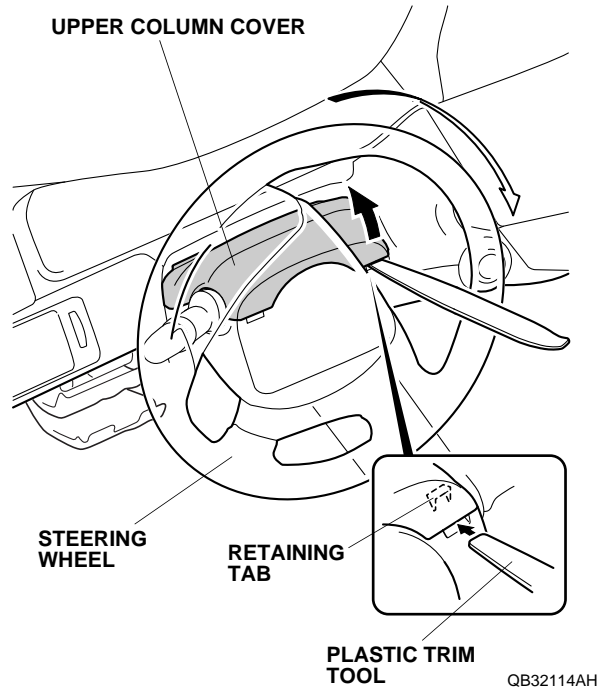

22. Turn the steering wheel 180° counterclockwise. Using a plastic trim tool, release the retaining tab.

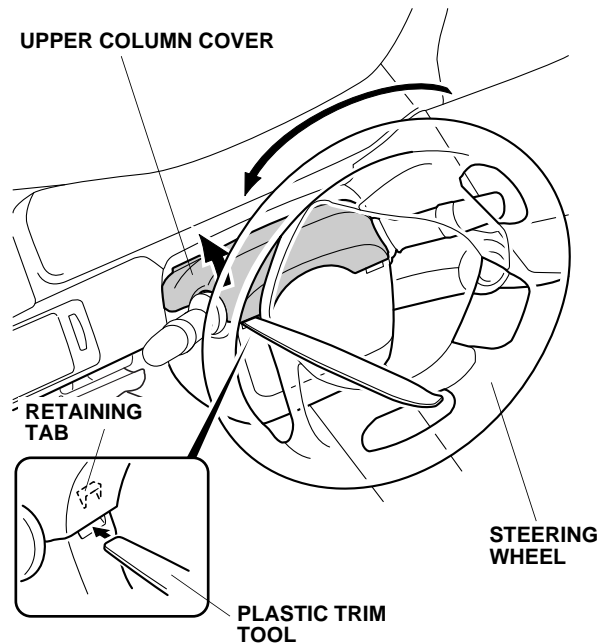

23. Remove the upper column cover (two retaining tabs and two hooks).

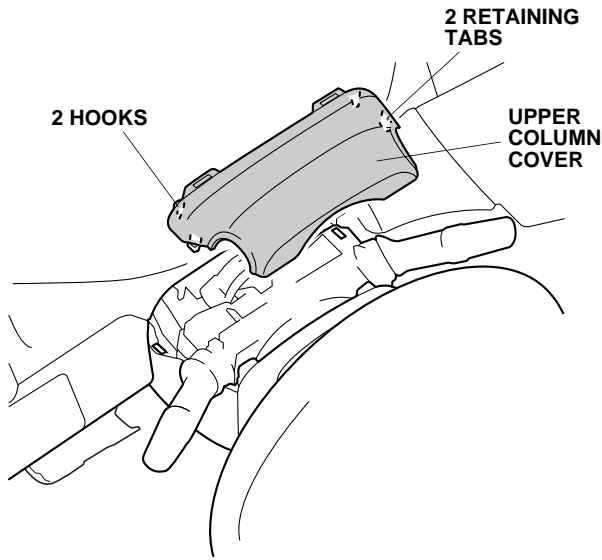

QB32116AH

24. Remove one self-tapping screw from the lower column cover.

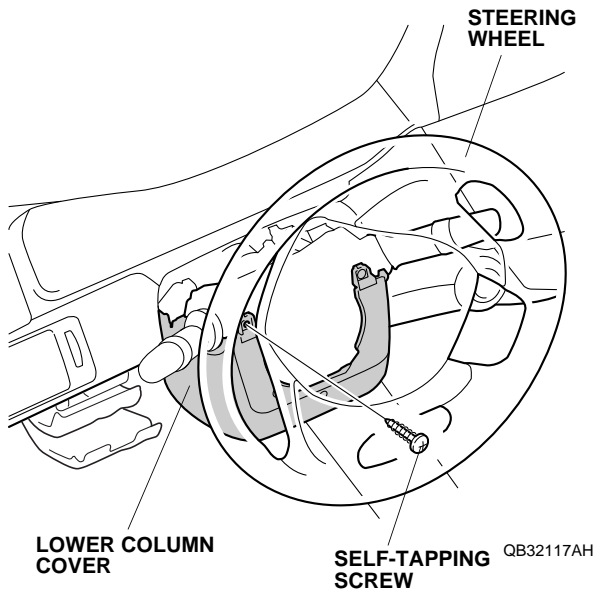

QB32117AH

25. Turn the steering wheel 180° clockwise, and remove the other self-tapping screw from the lower column cover.

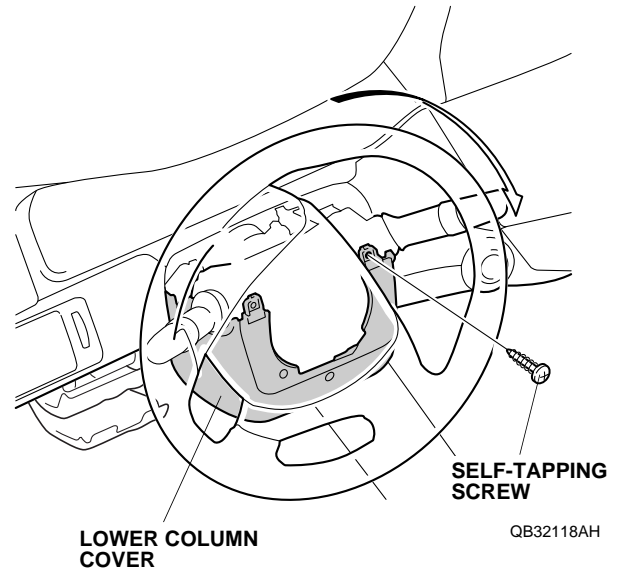

QB32118AH

26. Remove the lower column cover (one self-tapping screw).

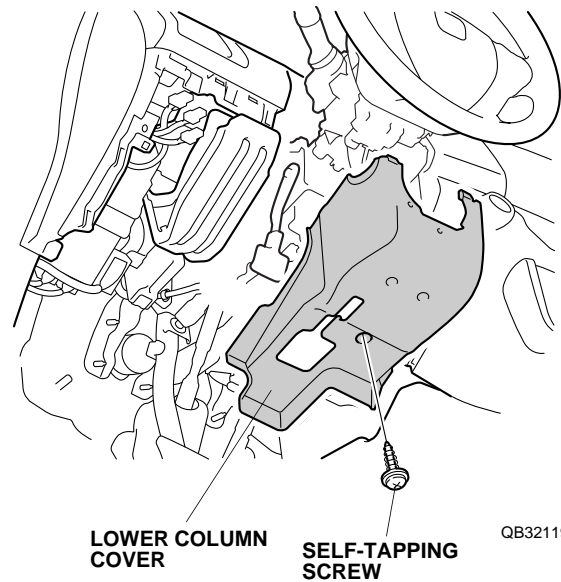

QB32119AH

27. If the vehicle is equipped with keyless access system, press the engine start/stop button to select the OFF mode. Disconnect the negative cable from the battery.

## Installing the Antenna

28. Using scissors, cut one urethane tape in half. Wrap two halves of urethane tape to the antenna cable as shown.

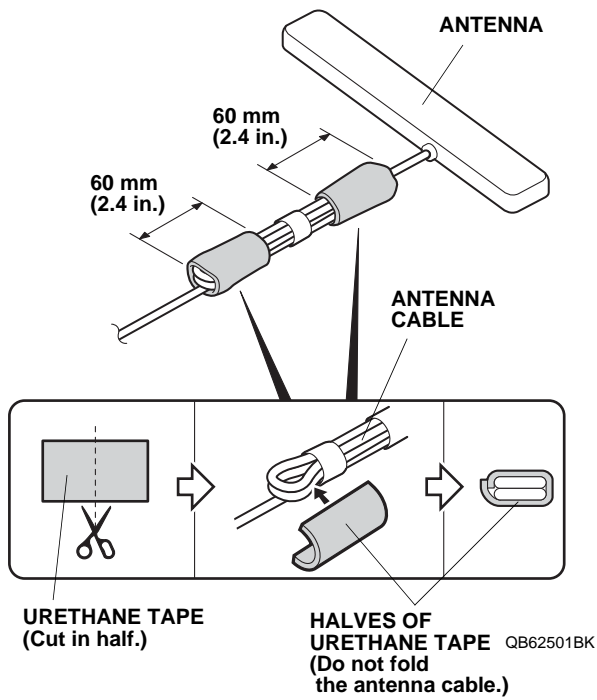

29. Starting near the antenna end of the cable, wrap one urethane tape around the antenna cable at the measurements shown.

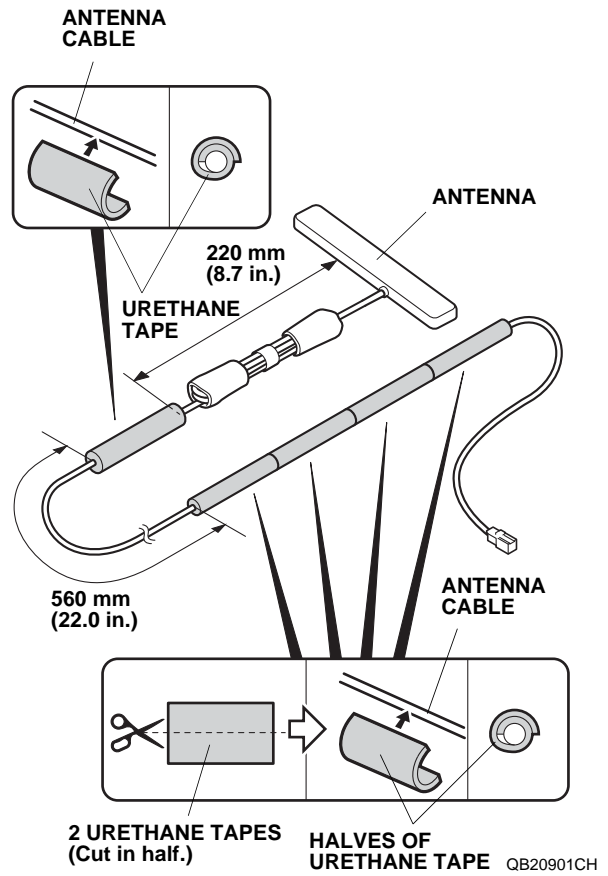

30. Using scissors, cut two urethane tapes in half. Wrap four halves of urethane tape around the antenna cable at the measurements shown.

31. Attach the antenna.
- Attach masking tape to the windshield at the measurement shown.

With Camera Cover

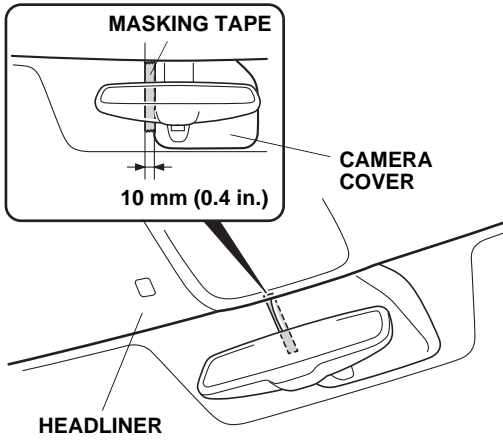

QB51403BH

Without Camera Cover

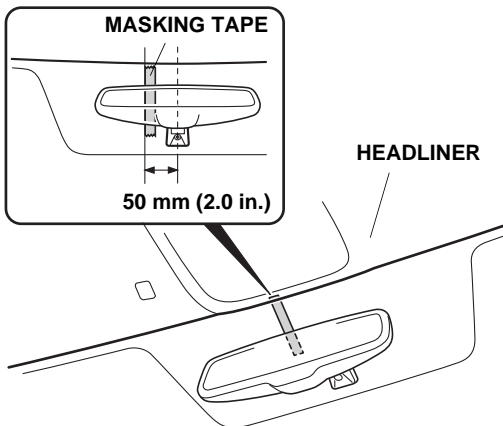

QB51402BH

- Fold the adhesive backing of the antenna as shown.

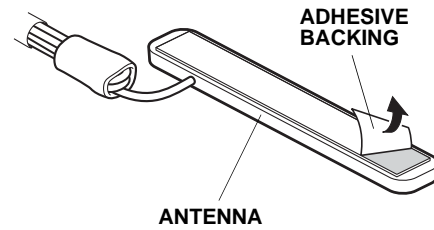

QB51401CH

- Using isopropyl alcohol on a shop towel, clean the windshield where the antenna will attach.
- Attach the antenna with masking tape. Adjust the position of the antenna so there is equal spacing on both sides.

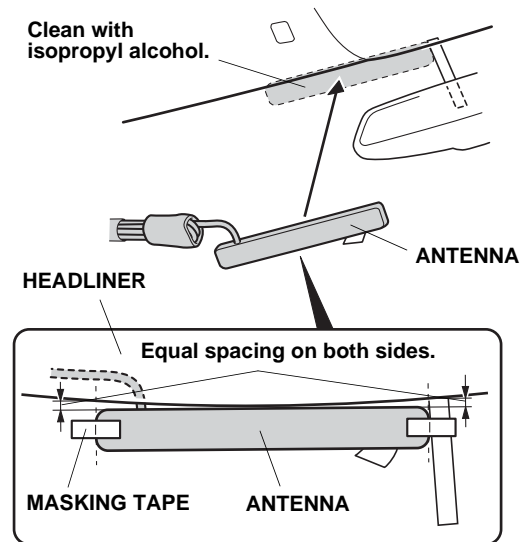

QB51404CH

- Carefully remove the adhesive backing from the antenna, and attach the antenna to the windshield. Press and hold the antenna firmly in place for 30 seconds.
- Remove the masking tape.

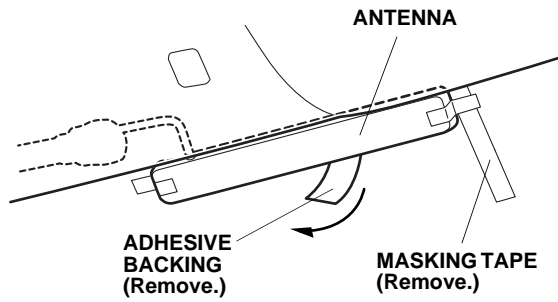

QB51405CH

32. Gently pull down the headliner, and tuck the antenna cable under the headliner. Be careful not to crease the headliner.

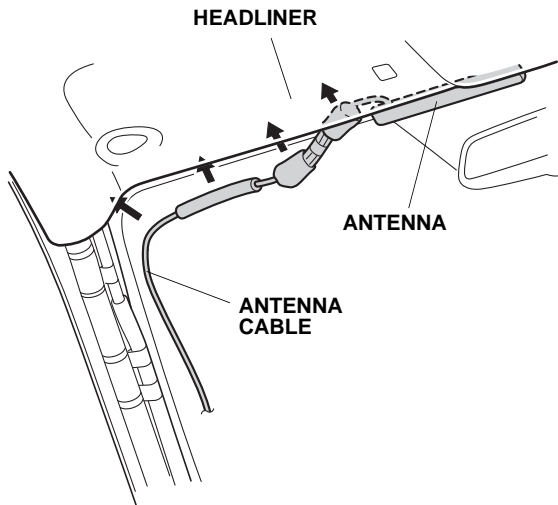

QB20904CH

33. Route the antenna cable down the A-pillar as shown. Using five wire ties, secure the antenna cable to the vehicle harness.

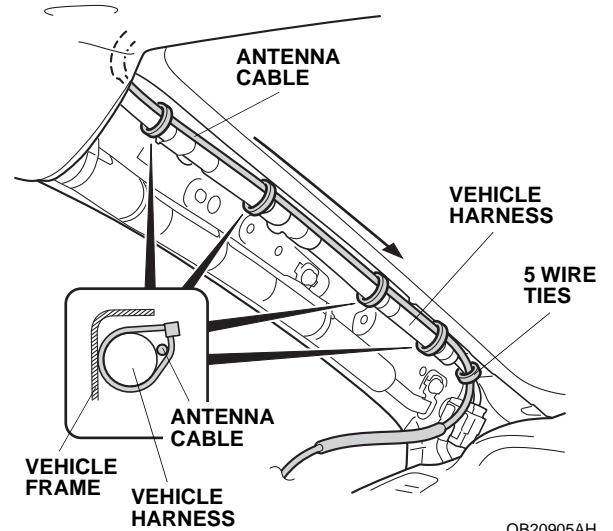

QB20905AH

34. Pull away the door opening seal. Route the antenna cable down next to the dashboard, and tuck the antenna cable between the driver's A-pillar and the dashboard. Reinstall the door opening seal.

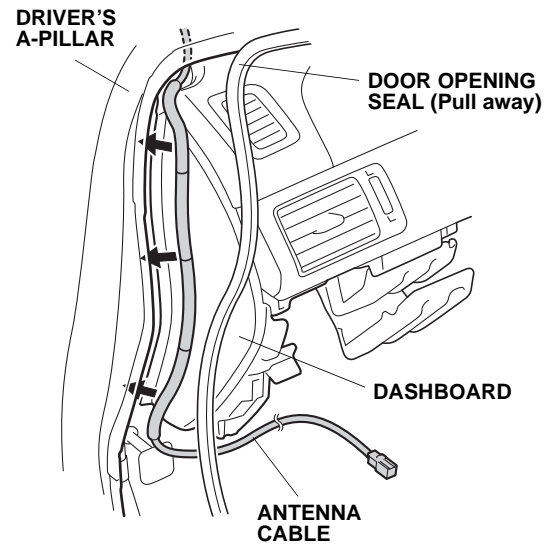

QB20906BH

## Routing the Engine Starter Harness

35. Using isopropyl alcohol on a shop towel, clean the areas where the fuse labels will attach.

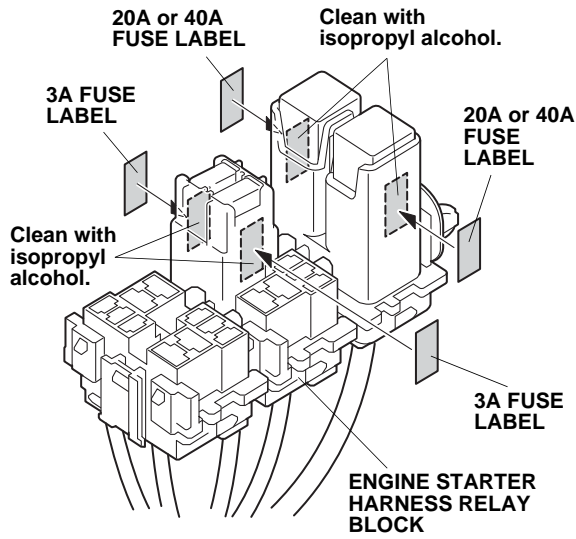

QB20907AH

36. Attach two 20A fuse labels (with keyless access system) or two 40A fuse labels (without keyless access system) and two 3A fuse labels to the engine starter harness relay block.
37. Install three relays to the engine starter harness relay blocks.

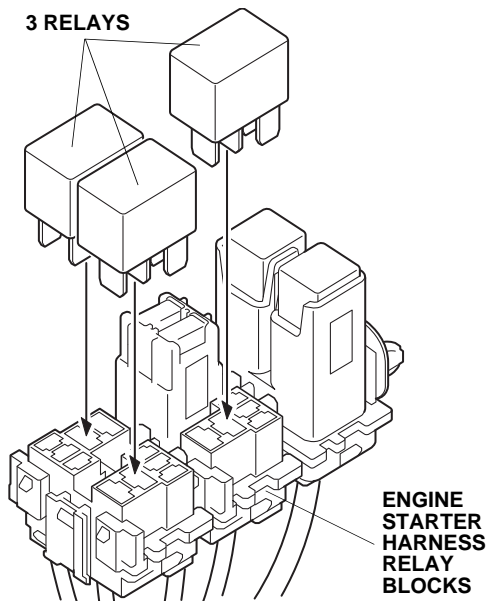

QB20908AH

38. Using scissors, cut one urethane tape to the measurements shown. Wrap the cut urethane tape around the engine starter harness 5-pin connector.

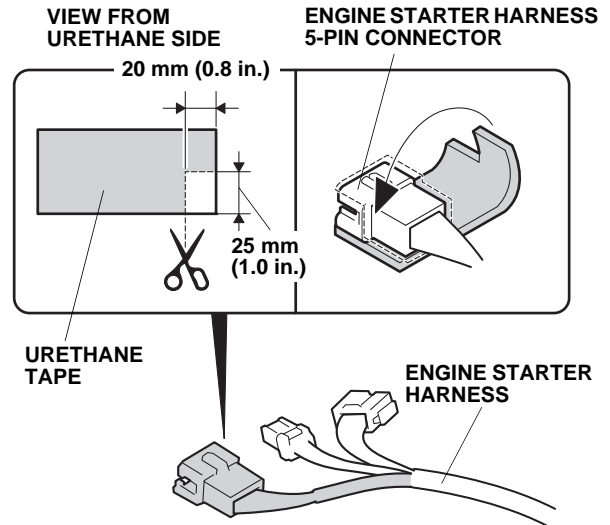

QB20909AH

39. Unplug the vehicle 5-pin connector from the fuse box. Plug the engine starter harness 5-pin connector into the fuse box 5-pin connector. Plug the vehicle 5-pin connector into the engine starter harness 5-pin connector.

**NOTICE:** Make sure the engine starter harness 5-pin connector is securely connected to the fuse box 5-pin connector. A loose connection can cause the engine to stall.

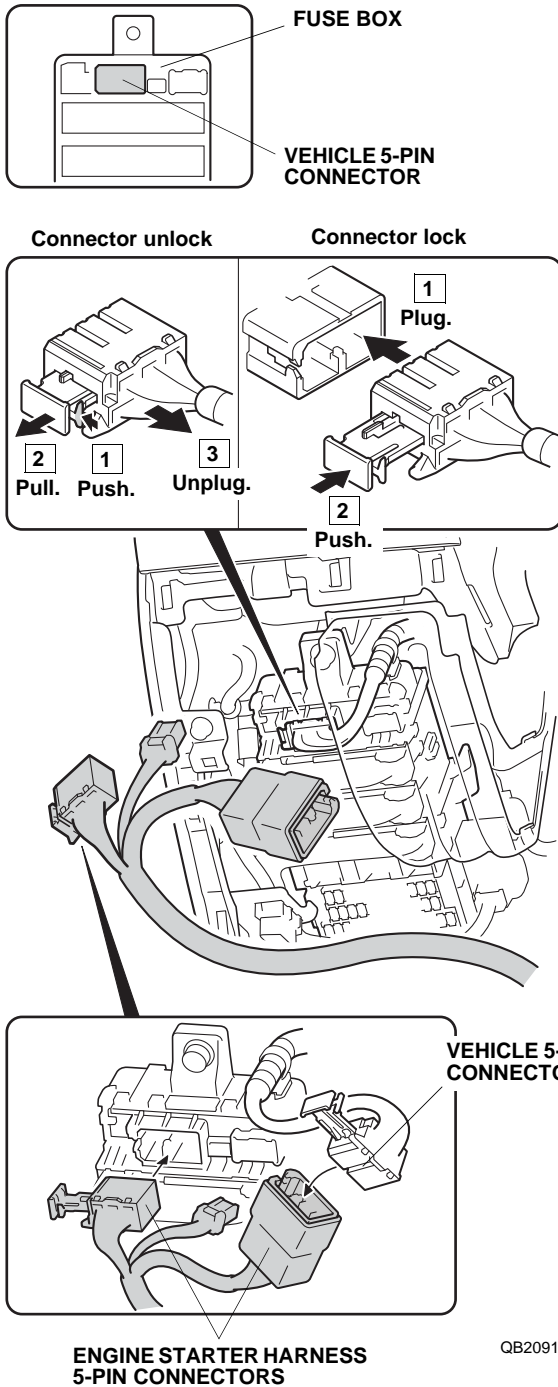

40. Using two wire ties, secure the engine starter harness to the vehicle harness.

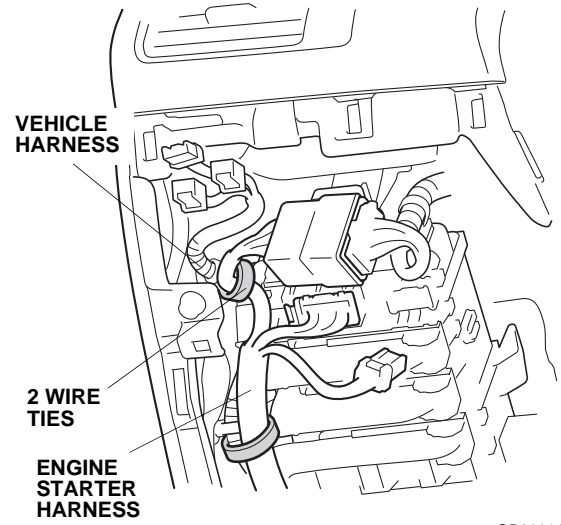

41. Plug the engine starter harness 4-pin connector into the fuse box.

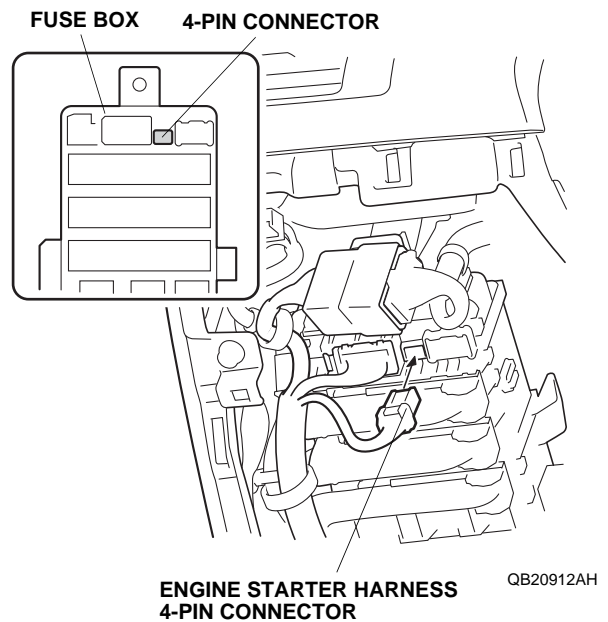

42. Route the engine starter harness as shown. Remove the tape from the vehicle harness. Do not damage the vehicle harness.

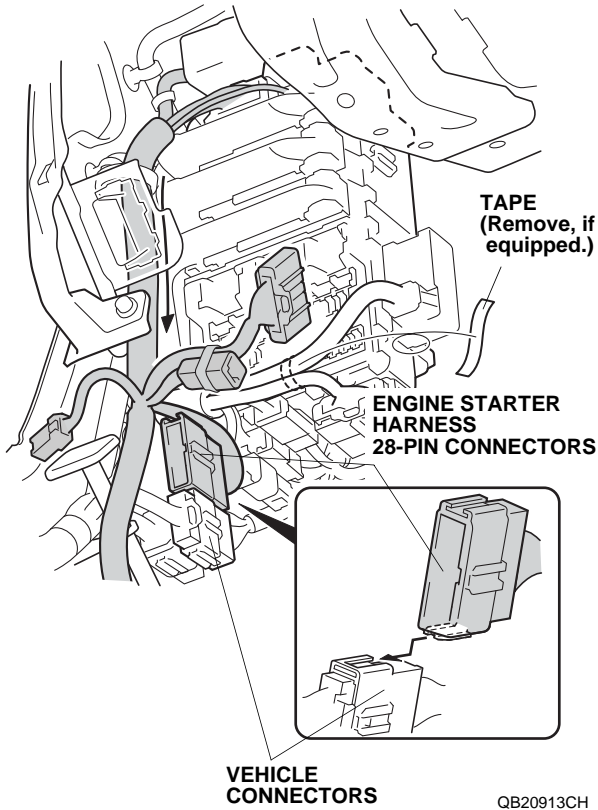

43. Attach the engine starter harness 28-pin connector to the vehicle connector.

44. Unplug the vehicle 28-pin connector, and plug it into the engine starter harness 28-pin connector. Plug the engine starter harness 28-pin connector into the vehicle 28-pin connector.

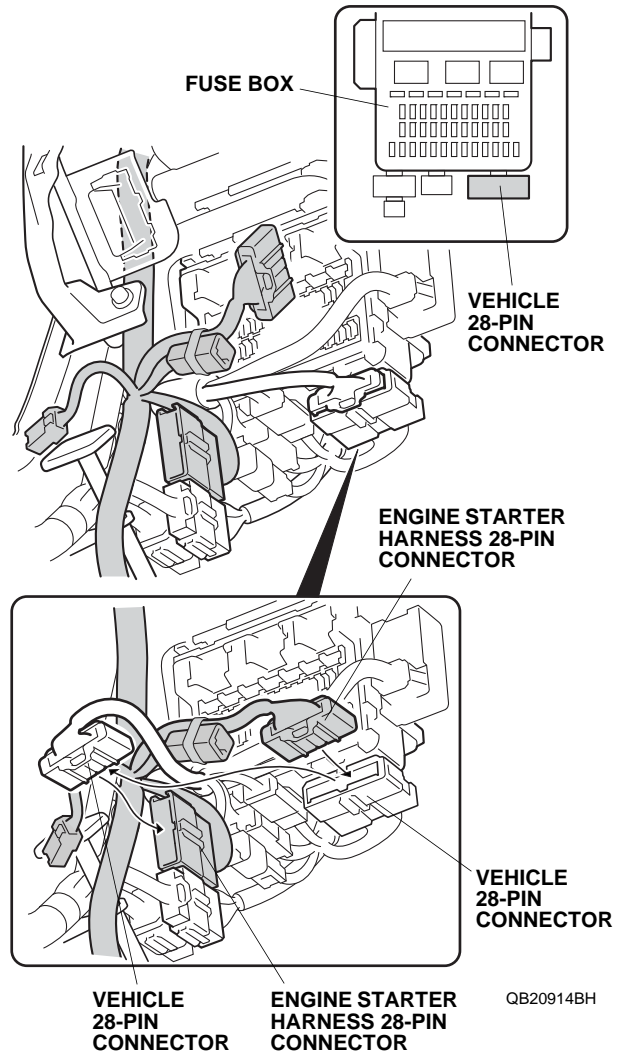



**With Keyless Access System**

- Remove the tape from the engine starter harness 2-pin connector. Unplug the vehicle 2-pin connector, and plug it into the engine starter harness 2-pin connector. Plug the engine starter harness 2-pin connector into the vehicle 2-pin connector.

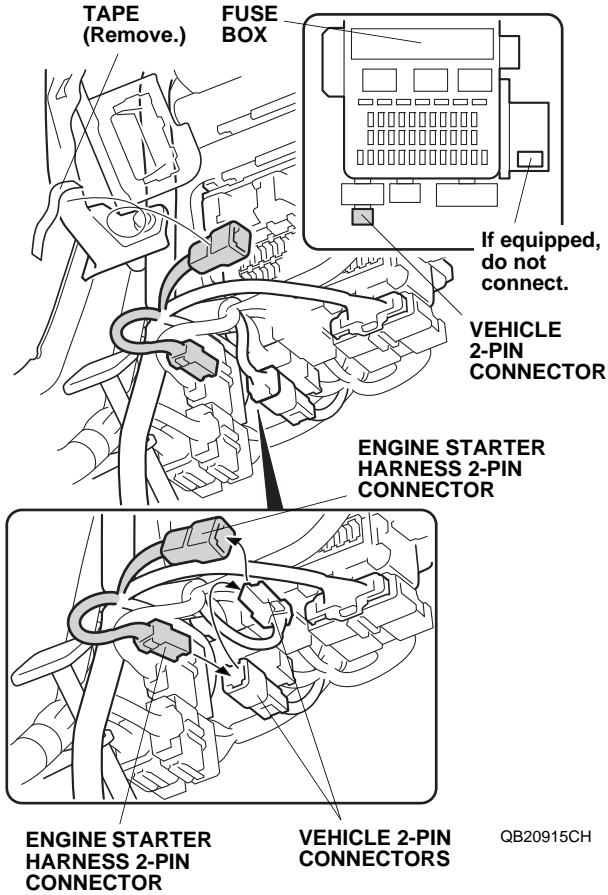

**Without driver's dashboard under cover**

- Using a utility knife, cut the dashboard insulator as shown. Go to step 48.

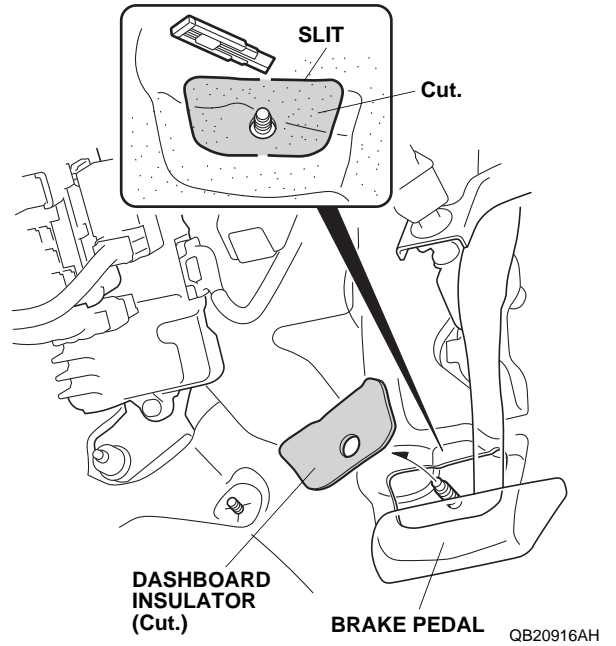

**With driver's dashboard under cover**

- Remove the cap from the vehicle bolt.

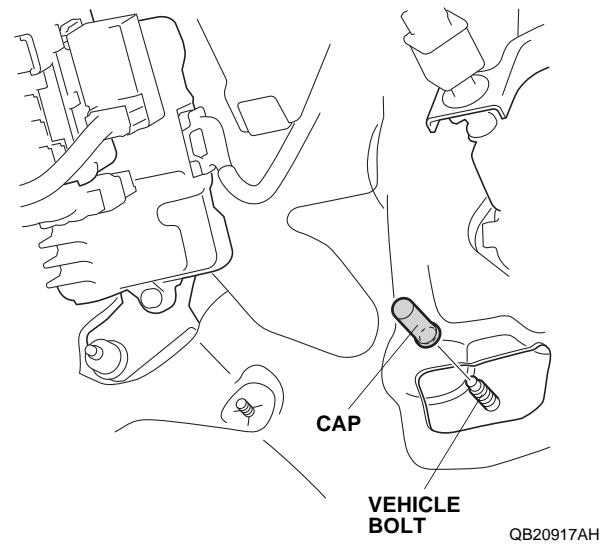

48. Using a utility knife, cut the dashboard insulator to the measurements shown. Do not damage the vehicle panel.

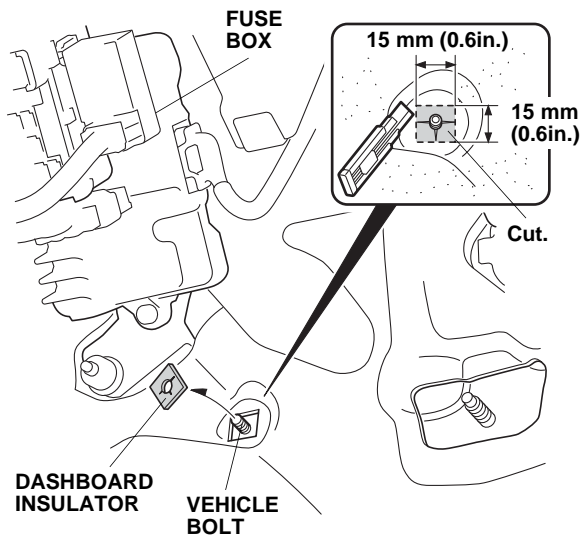

QB20918AH

49. Using isopropyl alcohol on a shop towel, clean the control unit where the urethane tape will attach.

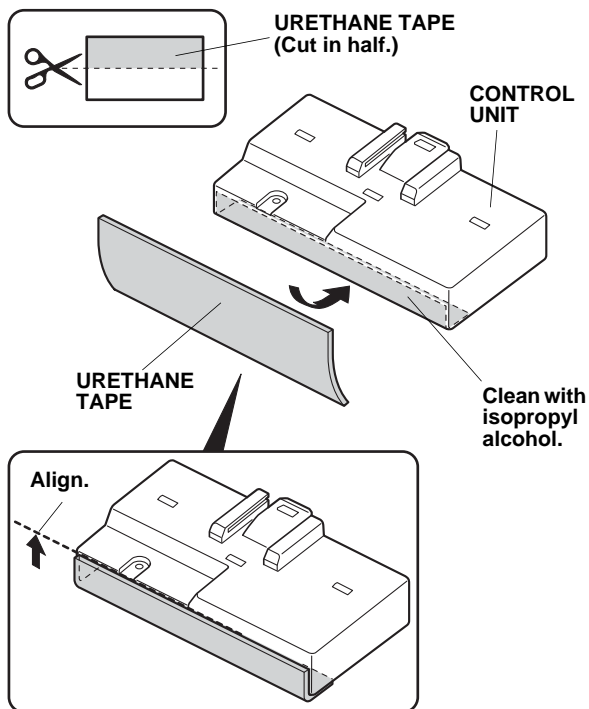

QB20919BH

50. Using scissors, cut the urethane tape in half, then wrap the urethane tape around the control unit.

51. Plug the antenna cable connector and engine starter harness 28-pin connector into the control unit.

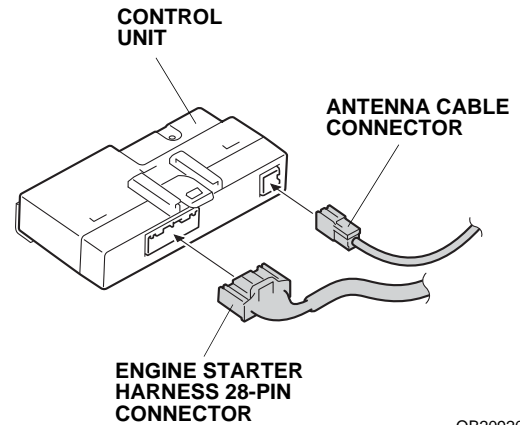

QB20920AH

52. Install the control unit bracket to the control unit.

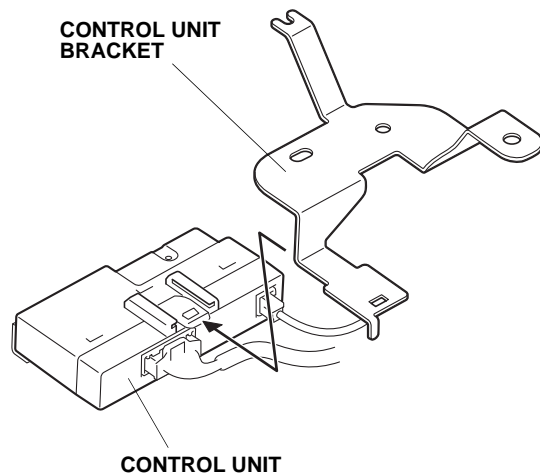

QB20921AH

53. Secure the engine starter harness clip to the control bracket.

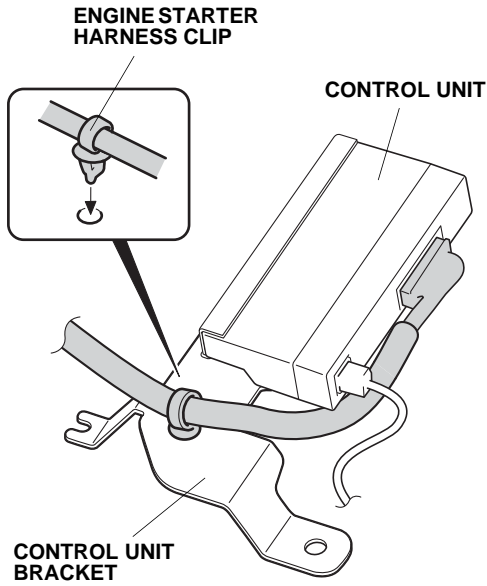

QB20922AH

54. Using two wire ties, secure the antenna cable to the engine starter harness.

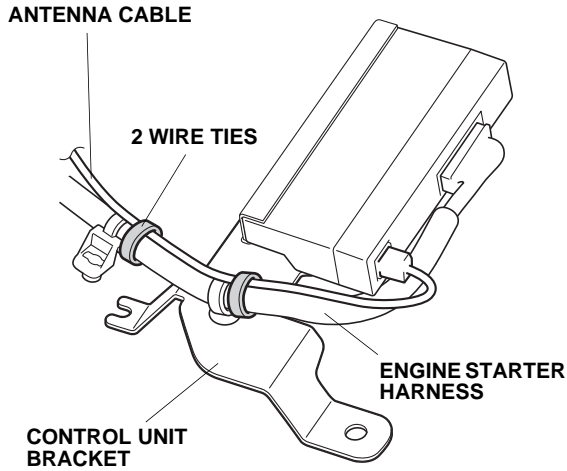

QB20923AH

55. Using one flange nut, secure the control unit bracket to the vehicle panel as shown.

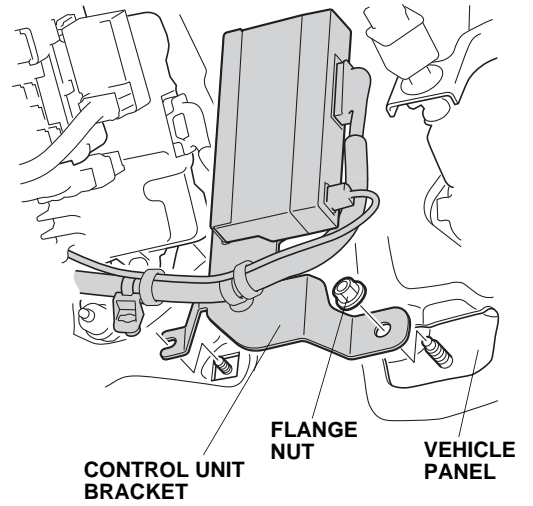

QB20924AH

56. Secure the engine starter harness clip to the vehicle bolt.

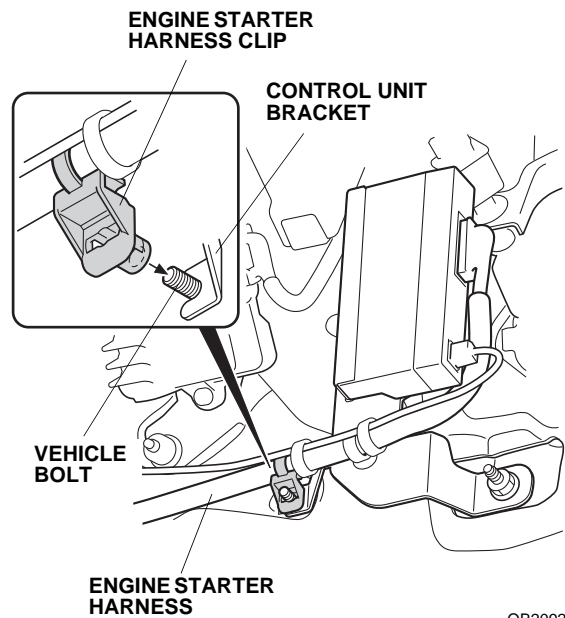

QB20925AH

57. Using isopropyl alcohol on a shop towel, clean the control unit bracket where the urethane tape will attach.

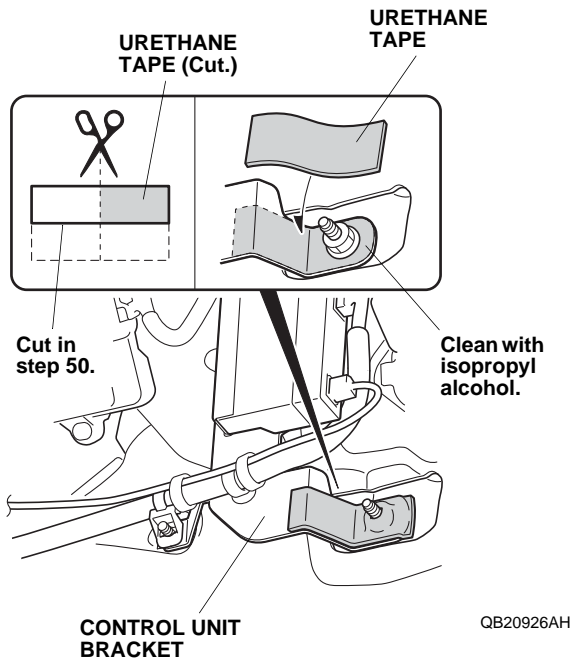

58. Using scissors, cut the urethane tape in half as shown, then attach the urethane tape to the control unit bracket.

With driver's dashboard under cover

59. Reinstall the cap to the vehicle bolt.

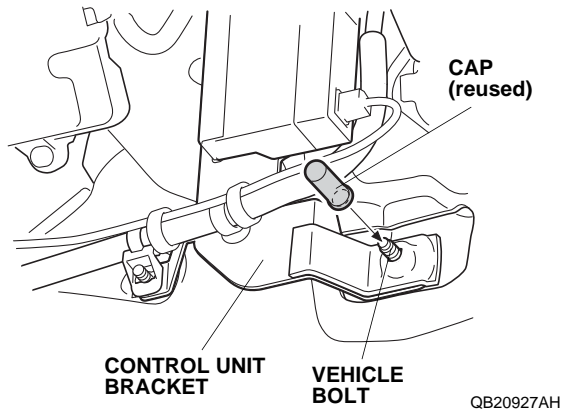

60. Attach the engine starter harness relay blocks to the control unit bracket.

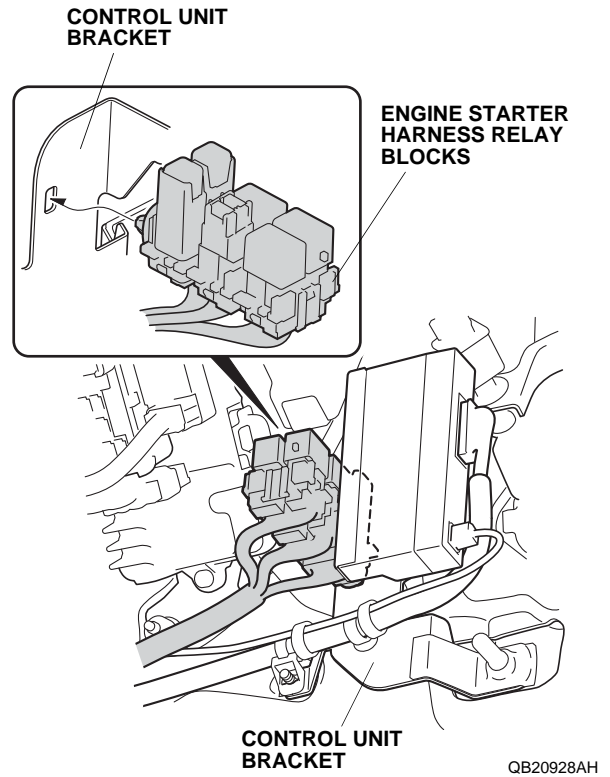

61. Remove the vehicle ground bolt.

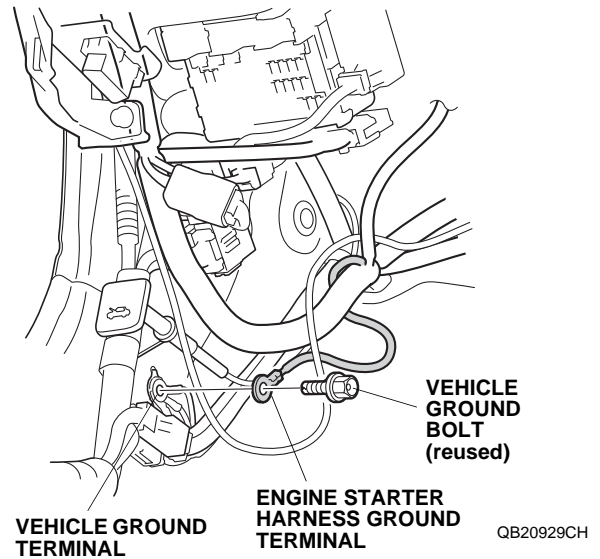

62. Attach the engine starter harness ground terminal to the vehicle ground terminal, and reinstall the vehicle ground bolt.

63. Using one wire tie, secure the antenna cable and engine starter harness to the vehicle harness.

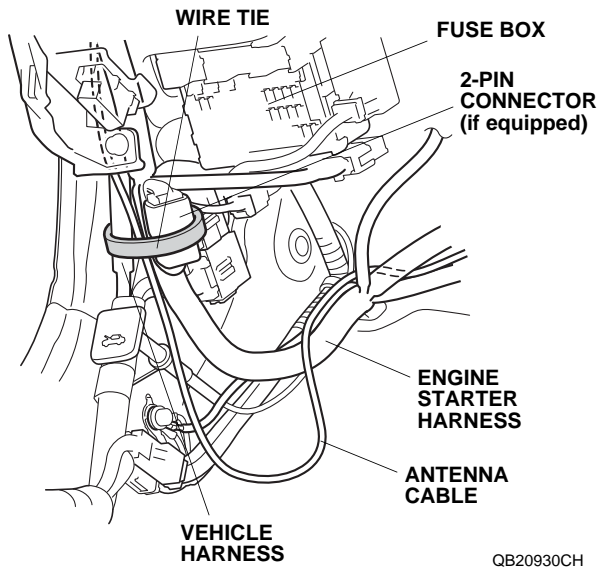

QB20930CH

64. Bundle up the excess antenna cable as shown. Using two wire ties, secure the antenna cable and engine starter harness to the vehicle harness.

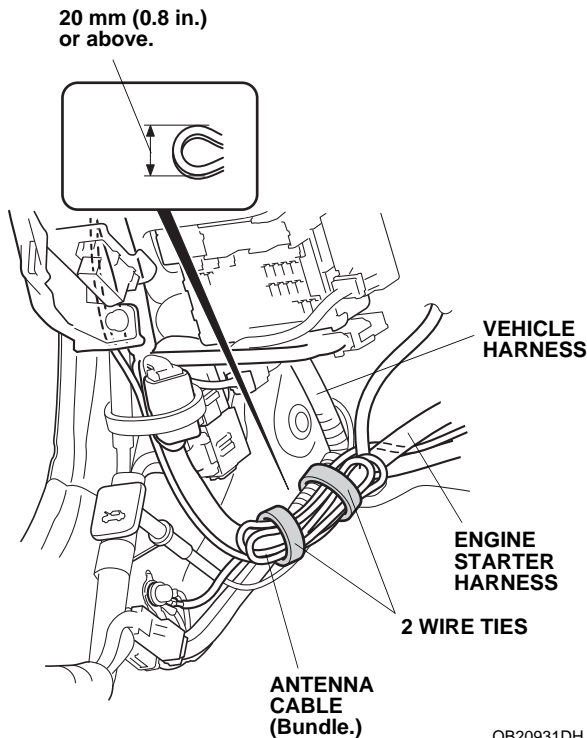

QB20931DH

65. Secure the engine starter harness to the hole in the vehicle frame with one wire tie with clip at the white tape on the engine starter harness.

NOTE: If another accessory harness is already attached, align the white tape on the engine starter harness with the clip on the other harness. Using one wire tie with clip, secure the engine starter harness to the other accessory harness.

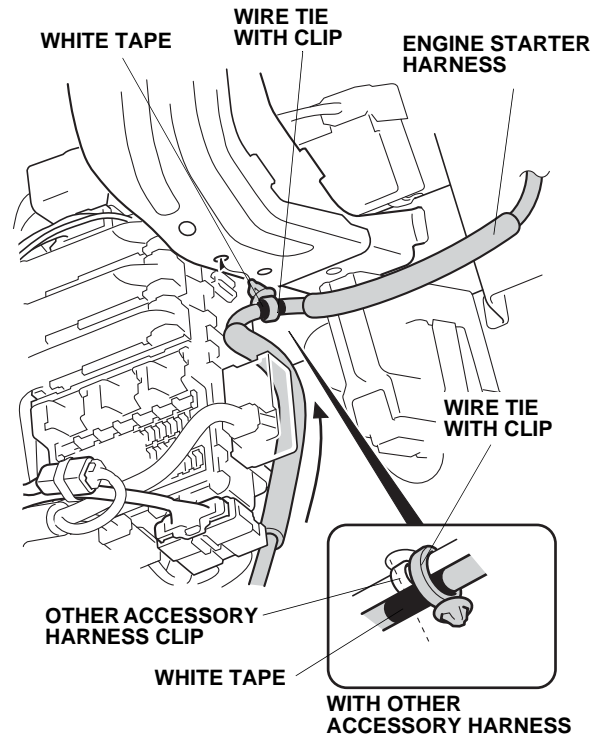

QB20932AH

66. Route the 12-pin/10-pin connector ends of the engine starter harness as shown.

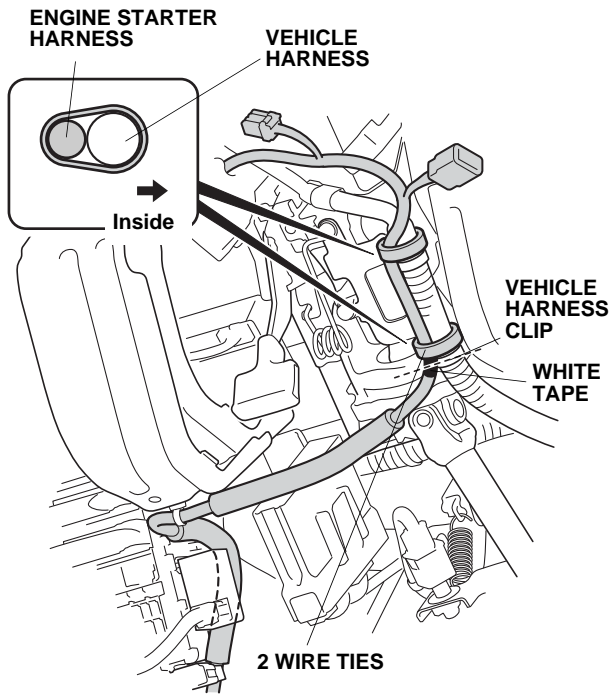

QB20933AH

67. Align the white tape on the engine starter harness with the clip on the vehicle harness, and secure the engine starter harness to the vehicle harness using one wire tie.
68. Using one wire tie, secure the engine starter harness to the vehicle harness.

69. Route the engine starter harness as shown. Unplug the vehicle 10-pin connector, and plug it into the engine starter harness 10-pin connector. Plug the remaining engine starter harness 10-pin connector into the wiper switch.

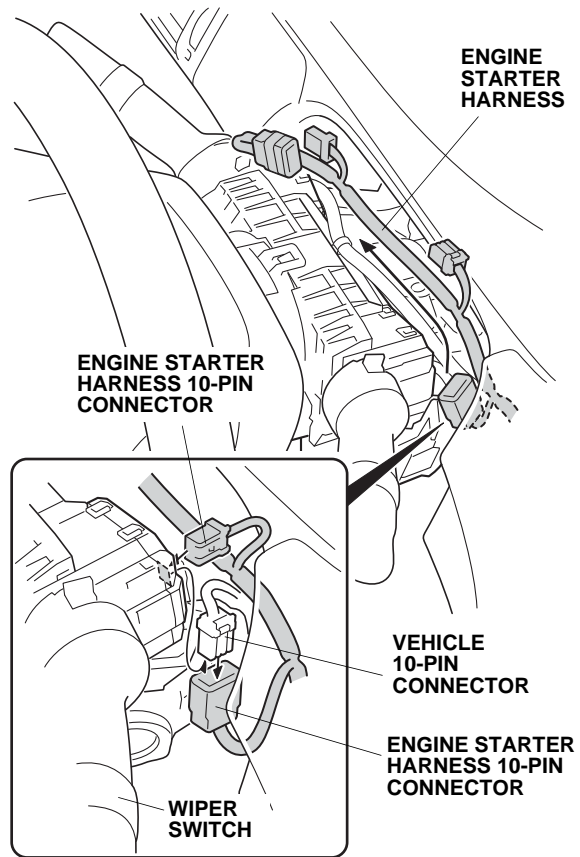

QB20934AH

70. Using one wire tie, secure the 10-pin connector and the engine starter harness to the vehicle harness.

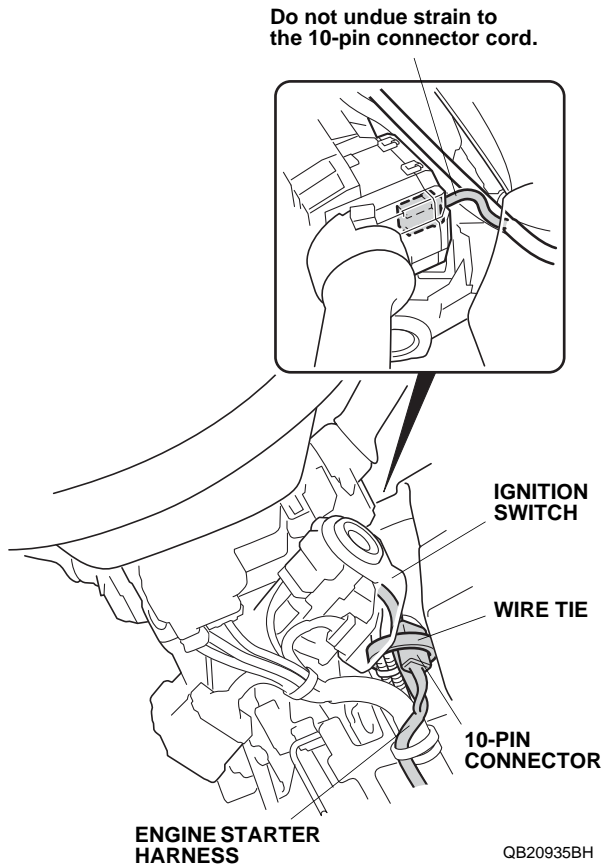

71. Route the engine starter harness as shown. Unplug the vehicle 12-pin connector, and plug it into the engine starter harness 12-pin connector. Plug the remaining engine starter harness 12-pin connector into the combination light switch.

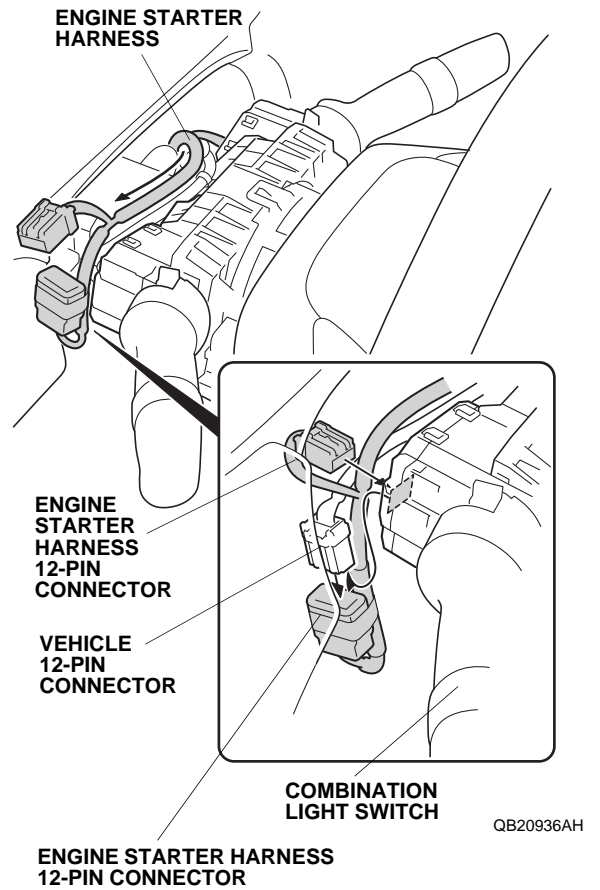

72. Using three wire ties, secure the engine starter harness to the vehicle harness. Do not secure it to the SRS harness.
- NOTE:** Make sure that the connectors and harness are not pinched, or are not interfering with the steering wheel when it is moved for adjustment.

**Do not pull the 12-pin connector cord wire too tight.**

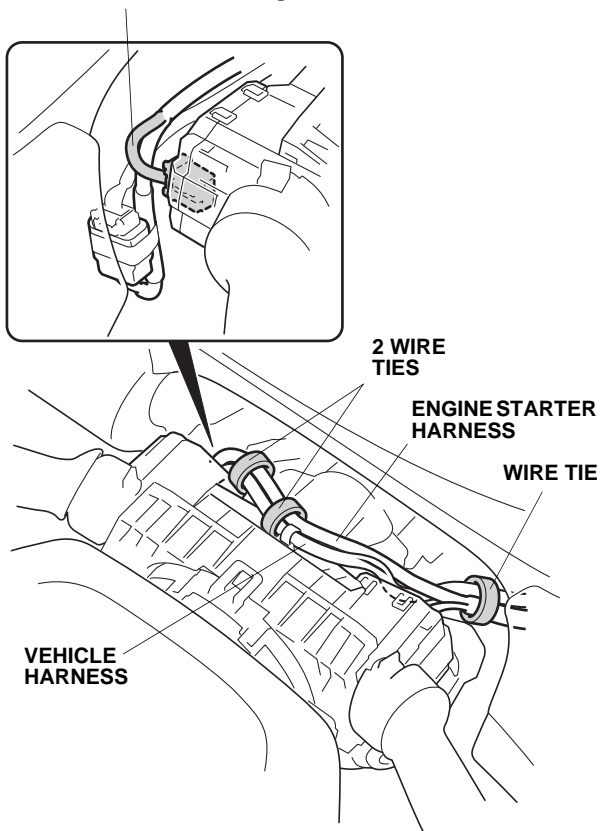

QB20937BH

73. Using isopropyl alcohol on a shop towel, clean the hood where the caution label will attach.

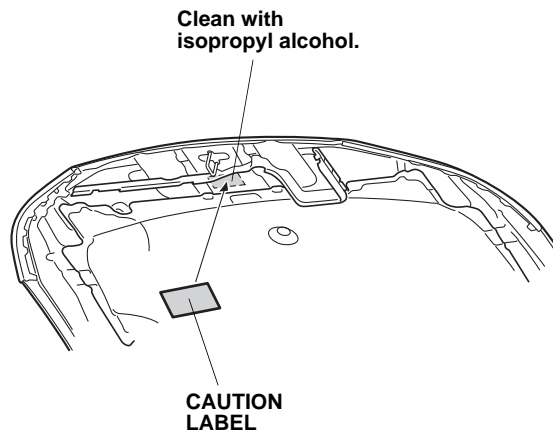

QB20938AH

74. Attach the caution label to the hood in the area shown.
75. Check that all wire harnesses are routed properly and all connectors are plugged in.
76. Check the overlap between the headliner and the driver's A-pillar trim. Refer to the Service Manual. If necessary, adjust the overlap.
77. Reinstall all removed parts.
78. Reconnect the negative cable to the battery.
79. Press and hold the radio power button for two seconds to restore the radio and navi (if equipped) system functions.
80. Reset the clock.
81. Perform the "REMOTE ENGINE STARTER REGISTRATION" and the "FUNCTION CHECK".



## REMOTE ENGINE STARTER REGISTRATION

1. Acquire the PCM Code from the Interactive Network.

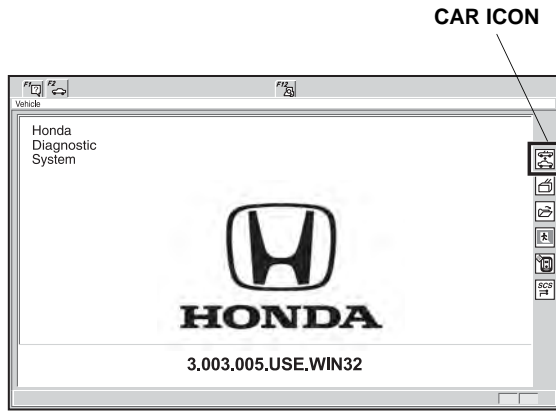

QB40150AH

2. Connect the HDS/MVCI tester to the OBD II data link connector, then turn the ignition switch to the on (II) position.
3. Start the HDS, and click the car icon.
4. Input the VIN and other required information into the HDS, then click the check button.

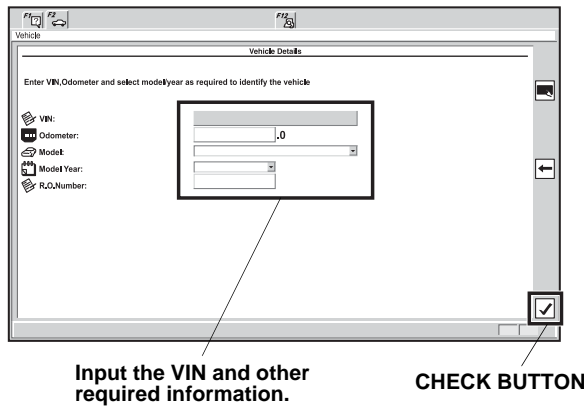

Input the VIN and other required information.

CHECK BUTTON

QB32102BH

5. Select **Honda Systems**, then click the check button.

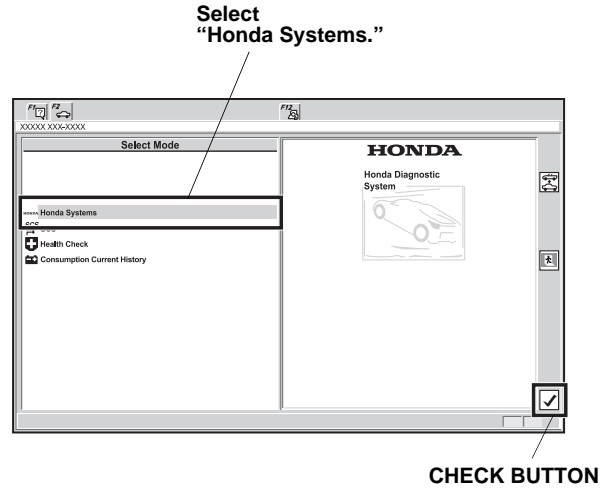

QB32103AH

6. Select **R/C ENG STARTER** and click the check button.

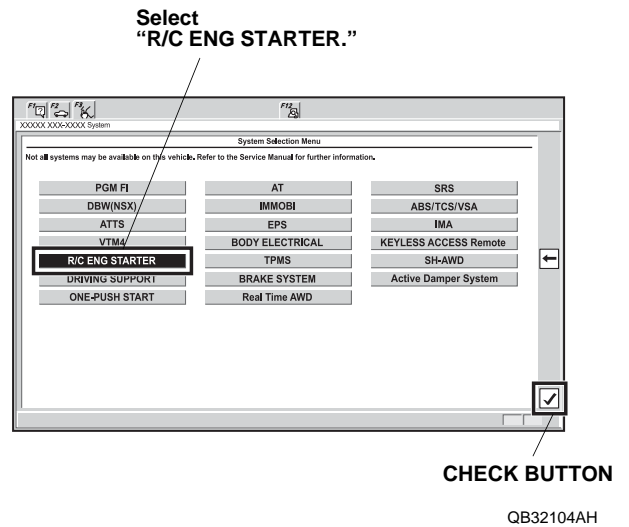

QB32104AH

7. Select **REGISTER REMOTE CONTROL ENGINE STARTER UNIT**, then click the check button.

Select  
"REGISTER REMOTE  
CONTROL ENGINE  
STARTER UNIT."

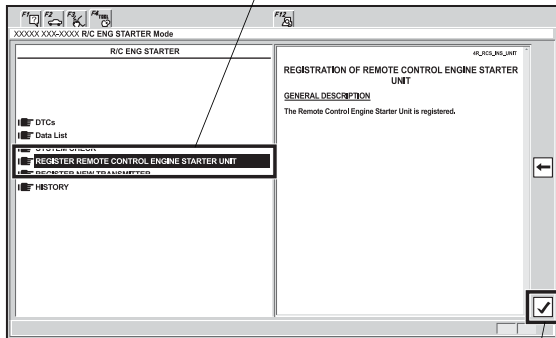

CHECK BUTTON

QB32105BH

8. The following message will display: **Obtain PCM-code (IMMOBILIZER PCM CODE) from iN. This vehicle's VIN will be required to obtain the password. (USA)** Click the check button.

"Obtain PCM-code"  
message.

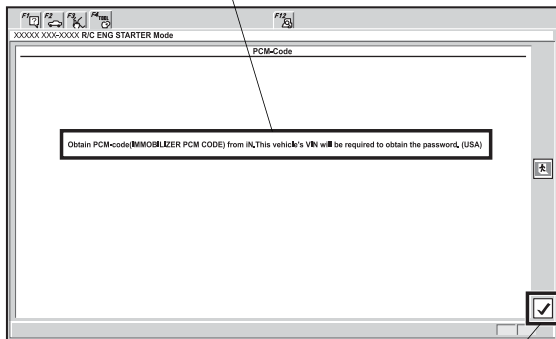

CHECK BUTTON

QB32106AH

9. Input the PCM-code, then click the check button.  
NOTE: To ensure security, the PCM-code (password) is changed everyday, so it is impossible to register the remote control engine starter if the dates of the PCM-code acquisition and registration are different. The date of the HDS/MVCI tester should also be the same.

Input the PCM-Code.

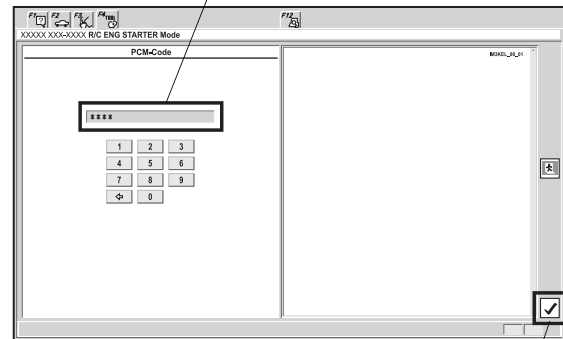

CHECK BUTTON

QB32107BH

10. The following message will display: **The registration of the Remote Control Engine Starter Unit has been completed.** Turn the ignition switch off.

**“The registration of the Remote Control Engine Starter Unit has been completed.”**

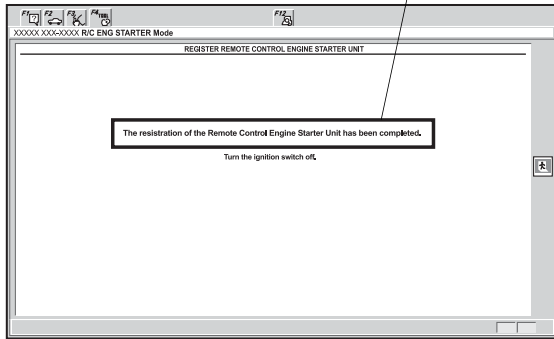

QB32108CH

11. The following message will display: **Check that engine can be started by the Transmitter.** Click the check button.

**“Check that engine can be started by the Transmitter.”**

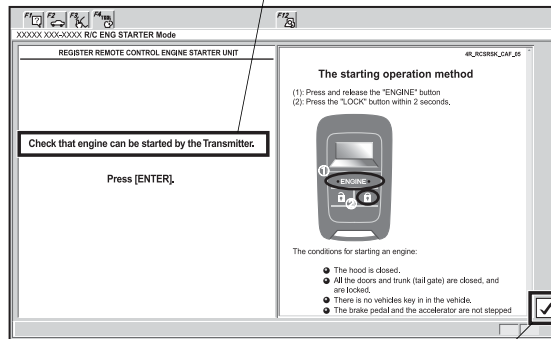

**CHECK BUTTON** QB32109CH

12. Perform the FUNCTION CHECK on page 28, then disconnect the HDS/MVCI.

## FUNCTION CHECK

### Operating Conditions

- The hood is closed
- The shift lever is in park
- Turn the ignition switch off and the key is outside the vehicle
- All doors and trunk lid closed and locked

### Inspection

1. Press the engine/command button on the transmitter and release, within 2 seconds, press the lock/start button on the transmitter.

The engine should start if all operating conditions are met.

Does the engine start?

Yes - Operation is normal.
No: <ul style="list-style-type: none"><li>• Make sure all “Operating Conditions” are met.</li><li>• Check the engine starter harness connections.</li><li>• Connect the HDS/MVCI and check for an indicated failure. (Refer to the appropriate Service Manual for details.)</li></ul>

- Press the engine/command button on the transmitter and release, within 2 seconds, press the unlock/stop button. The engine should stop.

Does the engine stop?

Yes - Operation is normal.
----------------------------

No - Check the engine starter harness connections.
--

- After the engine has stopped, start the engine again, and check that the engine stops after each of the following conditions:

NOTE: After each test the ignition key must be cycled, or the driver's door must be opened and closed.

- Move the shift lever out of the P position.
- Unlock or open the doors or the trunk lid.
- Open the hood.
- Insert the key in the ignition.
- If the vehicle is equipped the keyless access system, press the engine start/stop button.
- Press on the brake pedal.

Does the engine stop after each of these tests?

Yes - Operation is normal.
----------------------------

No - Check the engine starter harness connections.
--

- Check that the power windows and the moonroof do not function, and the shift lever does not move to any position when the engine is started with the transmitter.
- If the vehicle is equipped with the keyless access system, check that the engine does not start under "Operating Conditions" with the key left inside the vehicle.
- Start the engine again, press the engine/command button on the transmitter two times, and check the vehicle condition on the display.
- Check the operation of the transmitter when the vehicle is 120 m (400 ft.) away and in direct sight.
- Press the unlock/stop button on the transmitter and verify that the doors unlock. Press the lock/start button, and verify that the doors lock.  
For the vehicle equipped with the memory seat, make sure to shift the seat position of driver's seat to "Driver 1" by unlock of transmitter.
- Check that the engine can start by the vehicle key and that the wiper and the headlight can be operated normally.

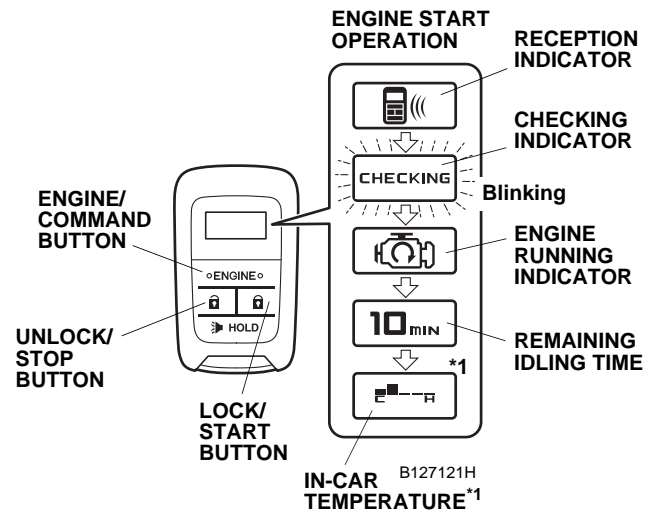

\*1 Only on vehicles equipped with the automatic climate control. This indicator is displayed for some vehicles among them.