

PARTS LIST

Remote Engine Starter Unit Kit P/N 08E91-E22-101A

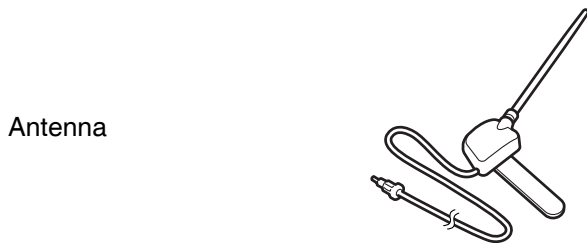

Accessory User's Information Manual

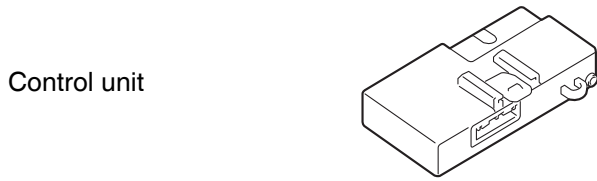
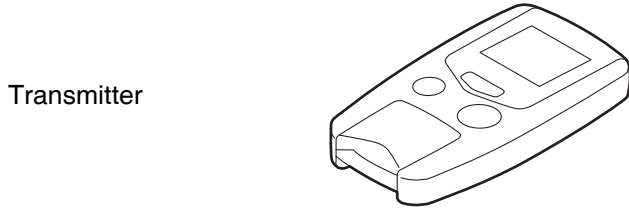
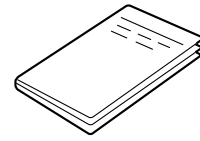

Quick start guide

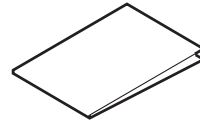

Remote Control Engine Starter Attachment Kit P/N 08E92-TA0-101

Engine starter harness

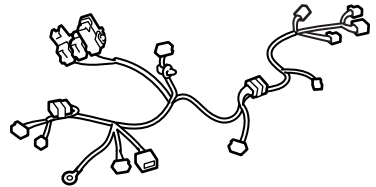

Control unit bracket



Template

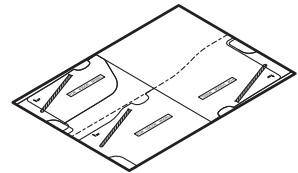

3 Relays

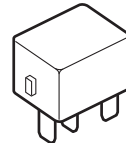

Ground bolt

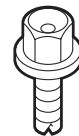

Flange nut



Illustration of the Remote Control Engine Starter Installed on the Vehicle

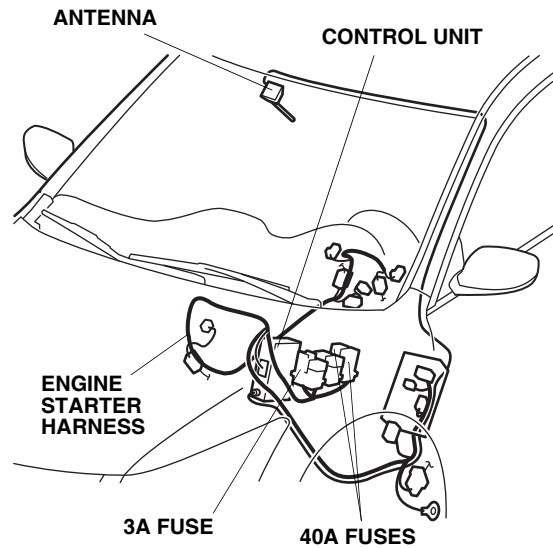

20 Wire ties

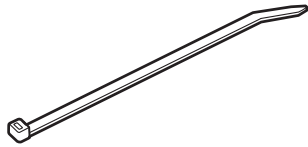

2 Long wire ties

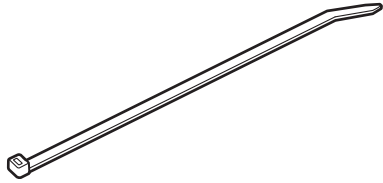

8 Urethane tapes

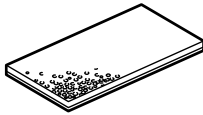

A-Pillar clip



TOOLS AND SUPPLIES REQUIRED

Flat-tip screwdriver
Phillips screwdriver
Small flat-tip screwdriver
Ratchet
10 mm Socket
10 mm Combination wrench
Isopropyl alcohol
Shop towel
Tape measure
Clip remover
Scissors
Small rubber mallet
Honda Diagnostic System (HDS)
Masking tape
2 Pairs of needle nose pliers
Diagonal cutters
Utility knife
Plastic Trim Tool (T/N SILTRIMTL10)

INSTALLATION

Customer Information: The information in this installation instruction is intended for use only by skilled technicians who have the proper tools, equipment, and training to correctly and safely add equipment to your vehicle. These procedures should not be attempted by “do-it-yourselfers.”

1. Make sure you have the anti-theft codes for the audio and navigation system (if equipped), then write down the radio station presets.
2. Disconnect the negative cable from the battery.

Setting the Control Unit

- Using a small flat-tip screwdriver, set the switches on the (accessory) control unit to the locations shown.

NOTE:

- The switches must be set before the control unit is plugged in.
- If the switch settings are not correct, the remote engine starter will not operate correctly.
- If setting the switches with the control unit installed in the vehicle, touch the metal part of the screwdriver to any metal part of the vehicle to discharge any static electricity.
- If you change the switch settings with the unit connected, you must disconnect the unit, then reconnect it before the new settings are recognized.

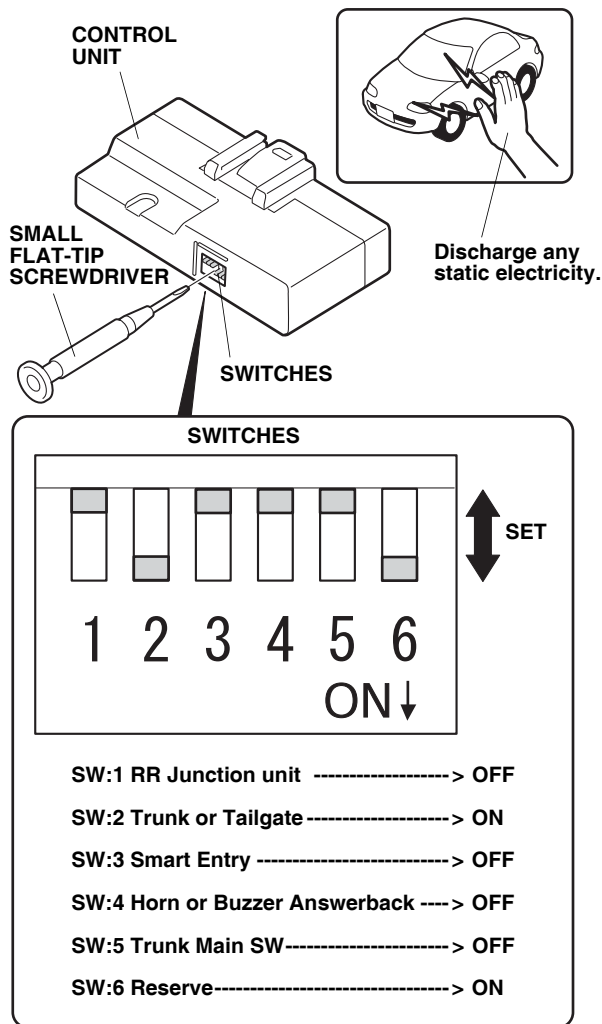

- Using isopropyl alcohol on a shop towel, clean the area where the protective tape will attach. Attach the protective tape to the control unit over the switches.

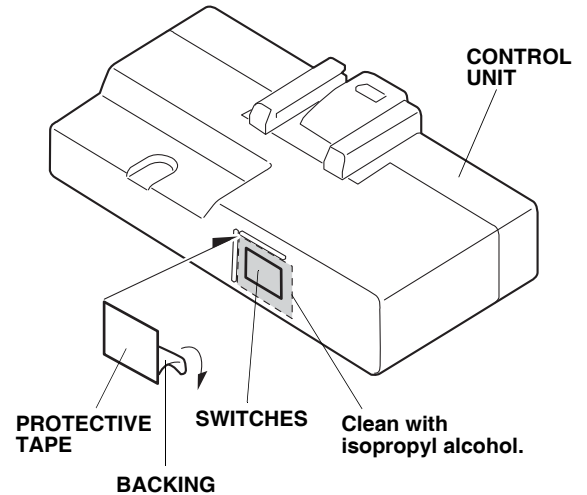

Removing the Vehicle Parts

- Using a plastic trim tool, disengage the eight retaining tabs and remove the left and right lenses from the roof console.

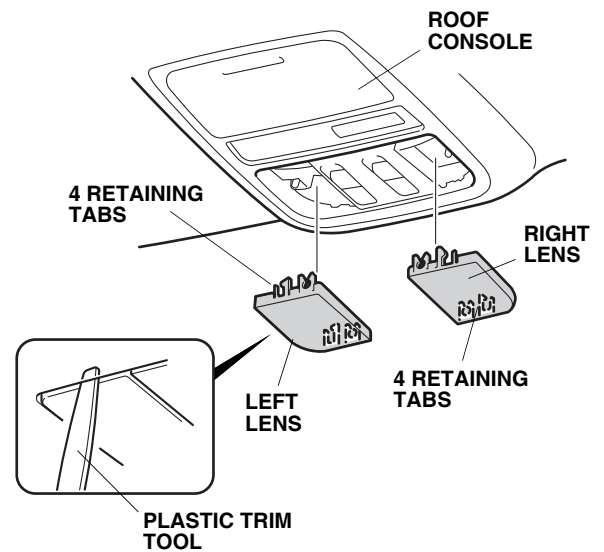

- Open the sunglass holder. Remove the four screws (two black and two silver) and let the roof console drop down. Unplug the vehicle connectors and remove the roof console.

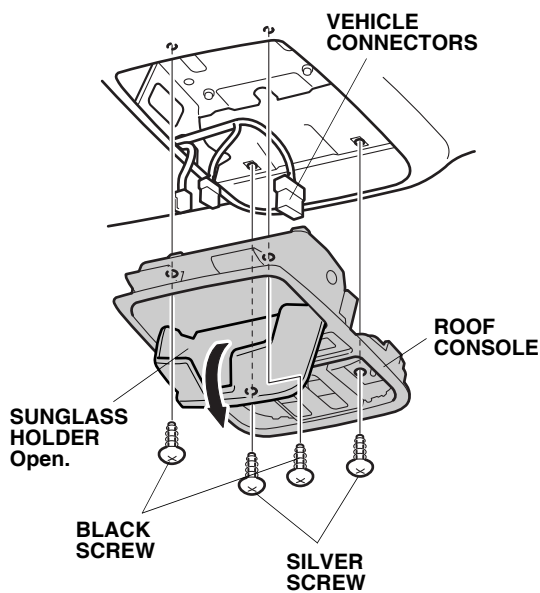

- Turn each sunvisor holder 45° to remove the two sunvisor holders.

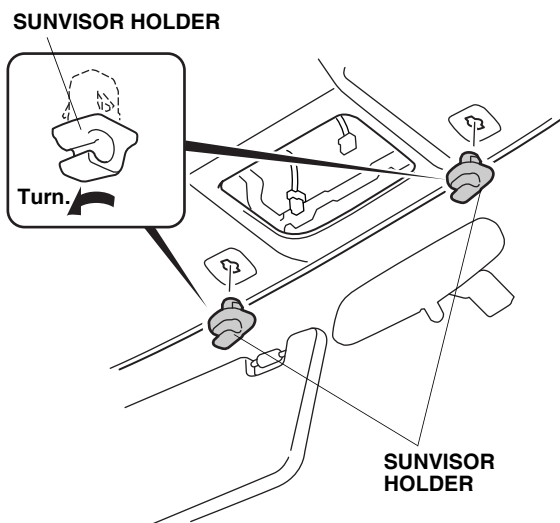

- Pull away the door seal from the left A-pillar trim.

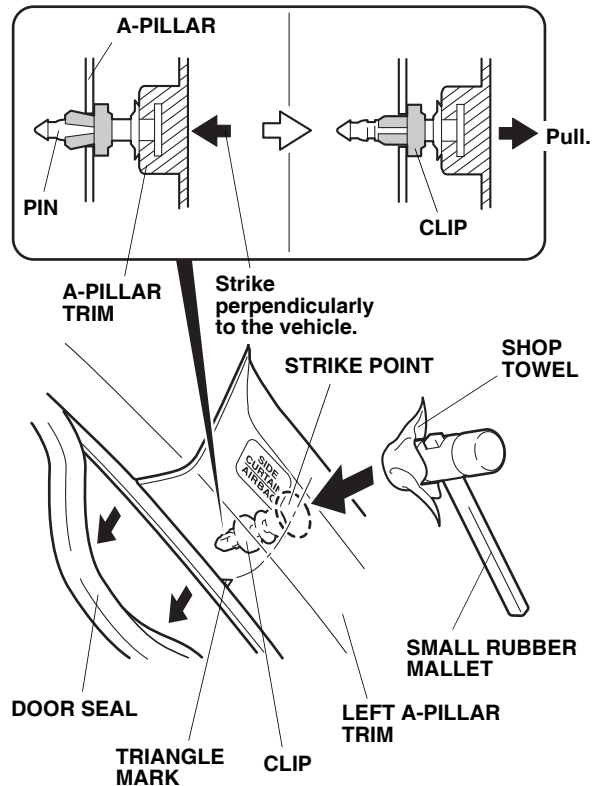

- Using a small rubber mallet and a shop towel, gently tap the left A-pillar trim at the position shown to release the clip.

- Pull away the remaining door seal from the left A-pillar trim, and remove the left A-pillar trim (two clips).

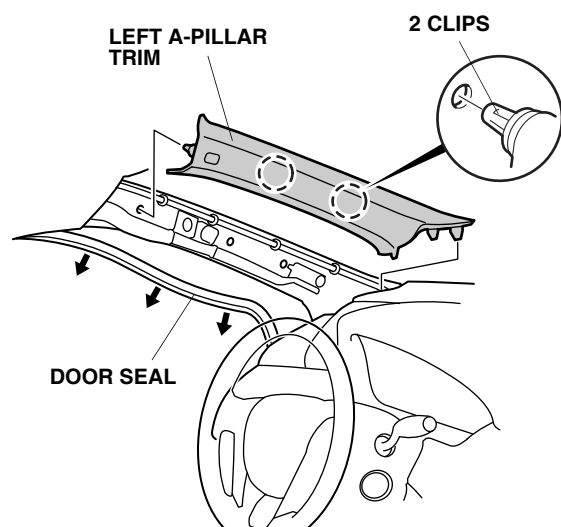

- Remove and discard the clip from the left A-pillar trim, and install a new A-pillar clip (supplied) onto the left A-pillar trim.

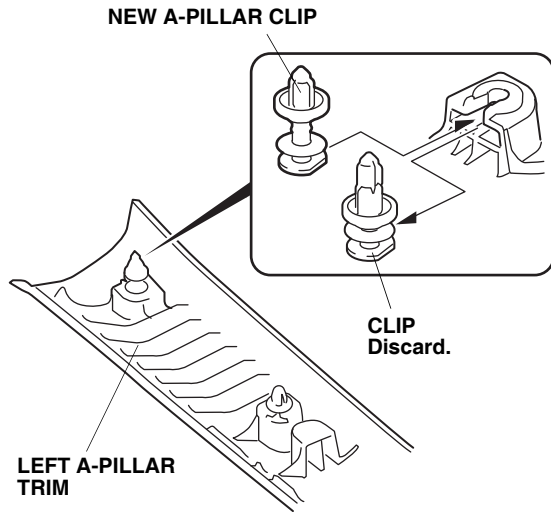

- Remove the driver's dashboard lower cover (eight clips, two hooks, and vehicle connector).

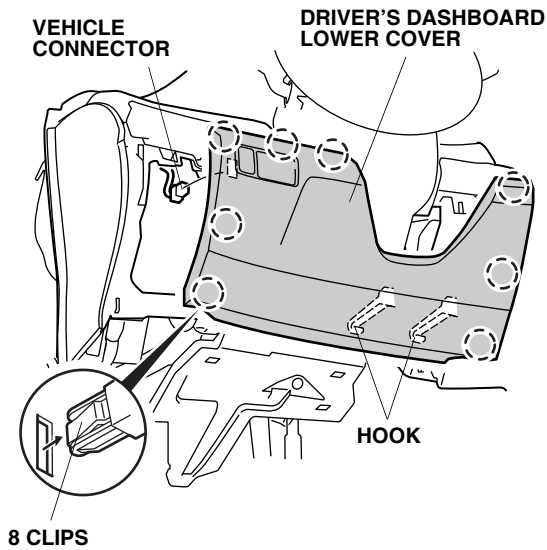

- Remove the driver's dashboard under cover (three clips and one pin).

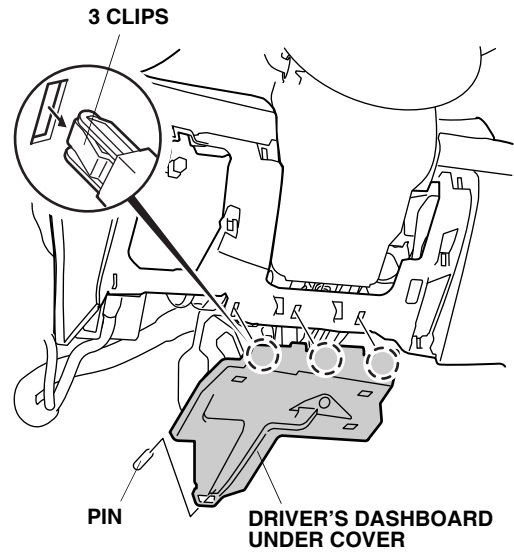

- Raise the front edge of the left front door sill trim, and remove the left front door sill trim (four clips and one retaining tab).

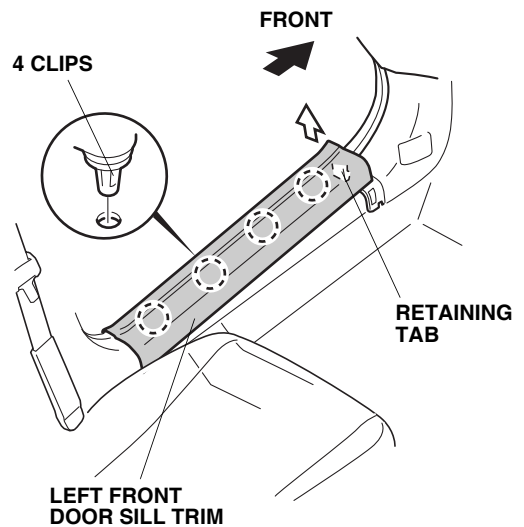

15. Pull away the door seal, and remove the left kick panel (two clips).

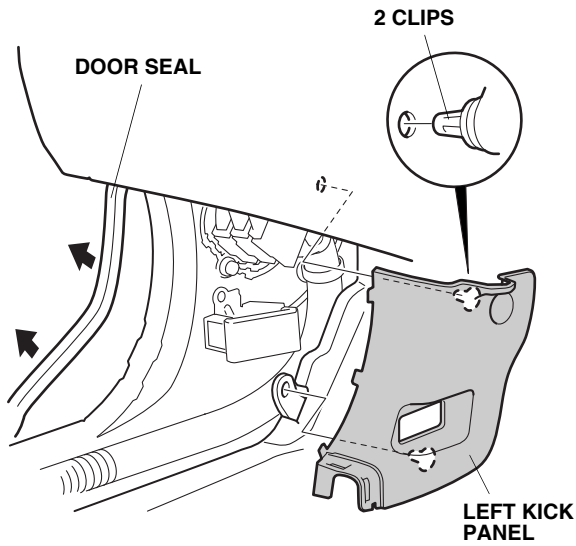

16. Pull away the door seal, and remove the driver's dashboard side lid (three clips, four tabs, and three hooks).

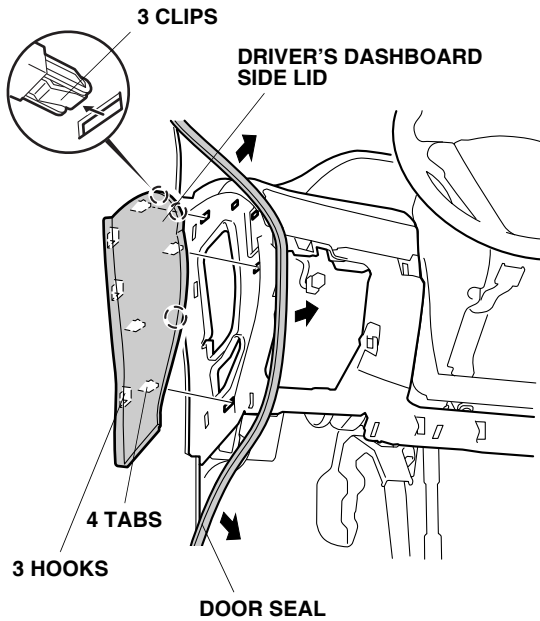

17. Lower the tilt lever and pull the steering wheel out.

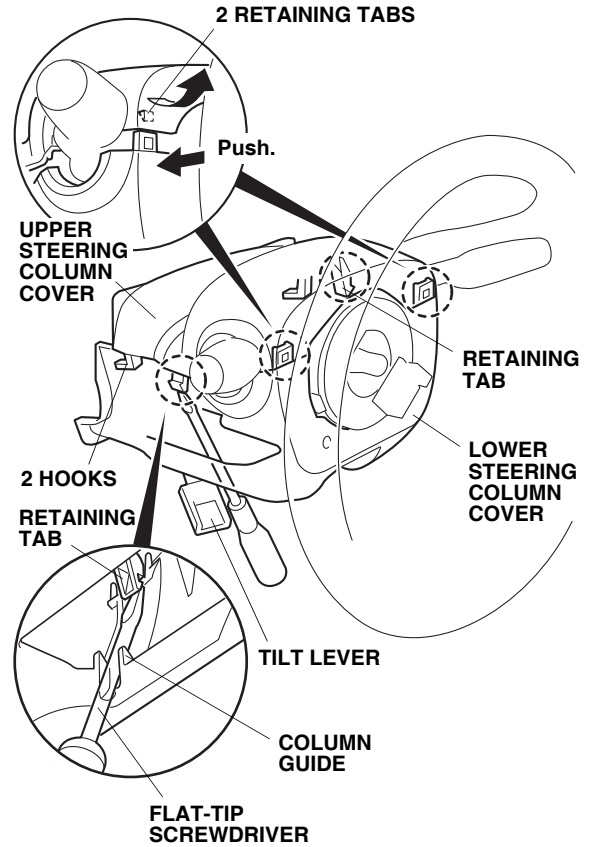

18. Remove the upper steering column cover:

- Insert a flat-tip screwdriver along the column guide inside the lower steering column cover, and gently pry out the retaining tab of the upper steering column cover.
- Push the lower steering column cover in at the areas shown to release the two retaining tabs, and pull up the upper steering column cover to release the two hooks and one retaining tab.

19. Remove the lower steering column cover (three screws). The upper screws are self-tapping screws.

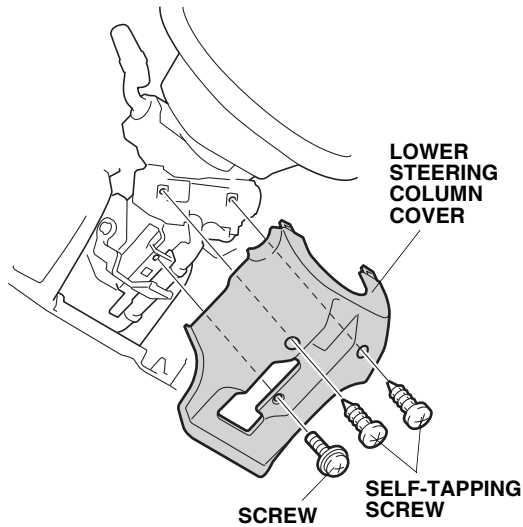

20. If equipped, remove the vehicle unit (two bolts and vehicle 28-pin connector).

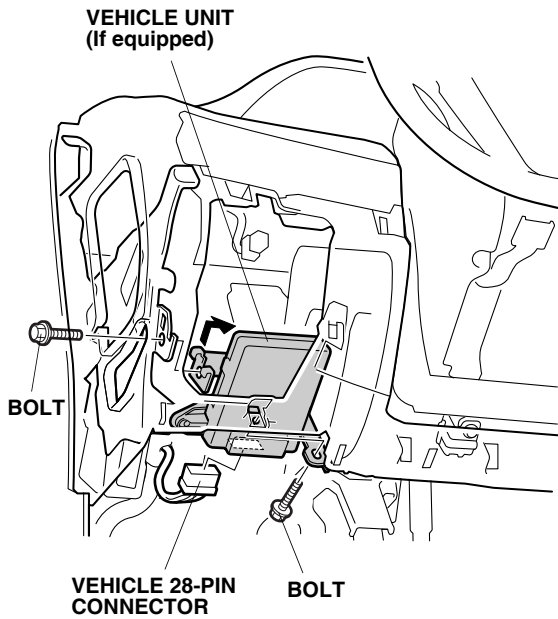

21. Remove the bolt, and remove the vehicle unit from the vehicle bracket.

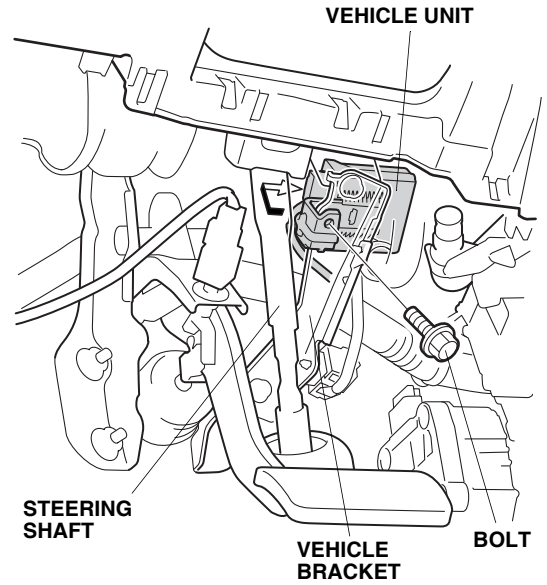

Routing the Engine Starter Harness

22. Using isopropyl alcohol on a shop towel, clean the areas where the fuse labels will attach.

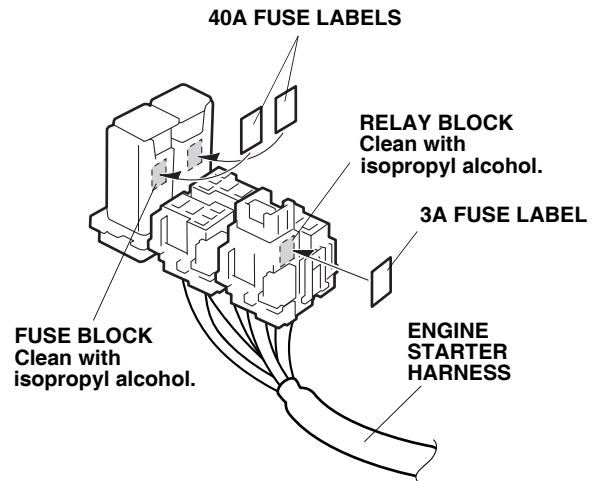

23. Attach the two 40A fuse labels to the engine starter fuse block.
24. Attach the 3A fuse label to the engine starter relay block.

25. Install the three relays to the engine starter relay blocks.

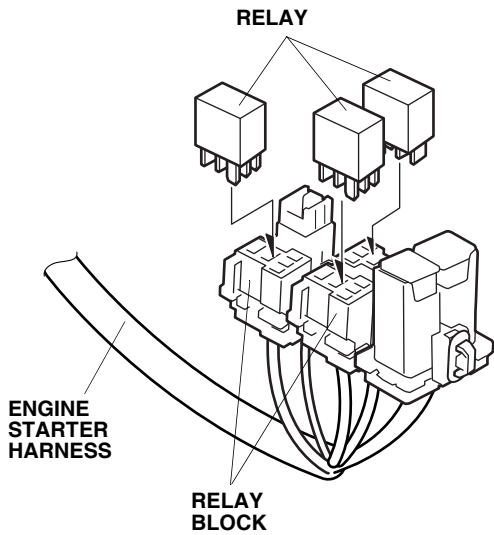

26. Route the 12-pin/8-pin/5-pin connector end of the engine starter harness over the vehicle bracket towards the center of the vehicle.

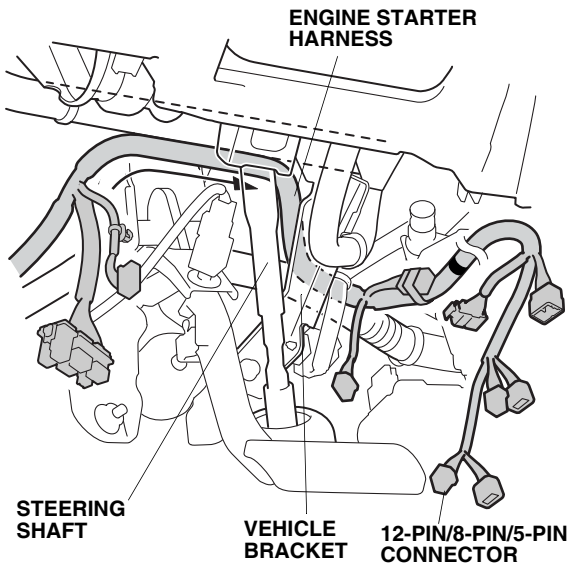

27. Route the 12-pin/8-pin/5-pin connector end of the engine starter harness to the ignition switch.

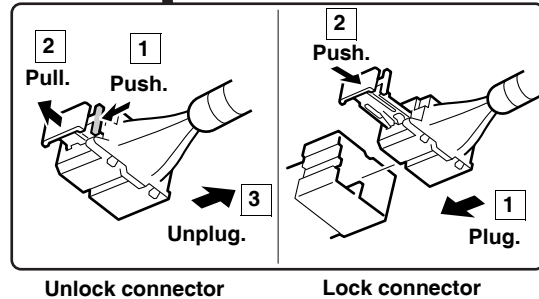
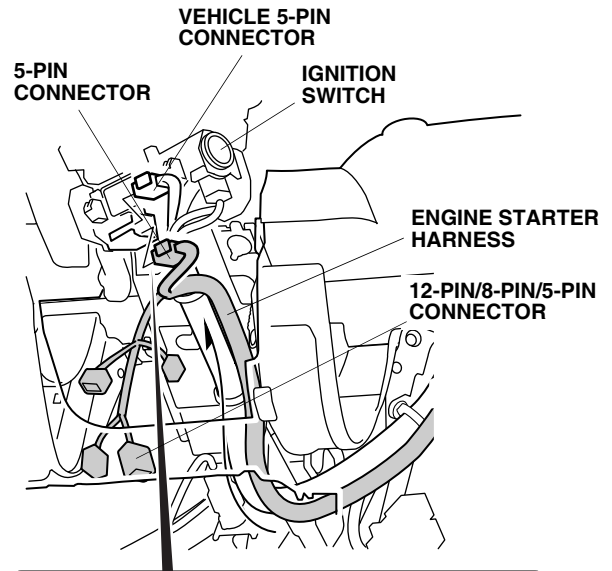

28. Unplug the vehicle 5-pin connector from the ignition switch, and plug the engine starter harness 5-pin connector into the ignition switch.

NOTICE: Check that the engine starter harness 5-pin connector is securely connected to the ignition switch. A loose connection can cause the engine to stall.

29. Wrap one urethane tape around the vehicle 5-pin connector, and tuck it into the area shown.

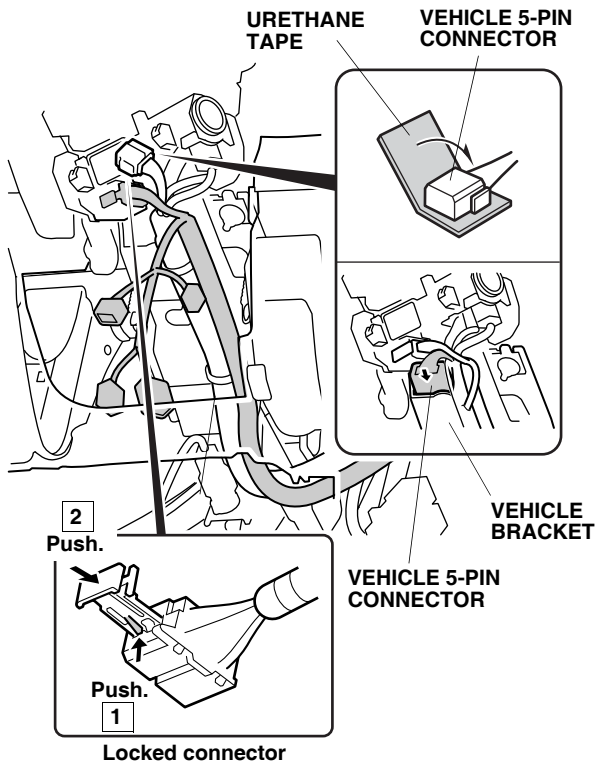

30. Unplug the vehicle 12-pin connector and plug it into the engine starter harness 12-pin connector. Plug the remaining engine starter harness 12-pin connector into the combination light switch.

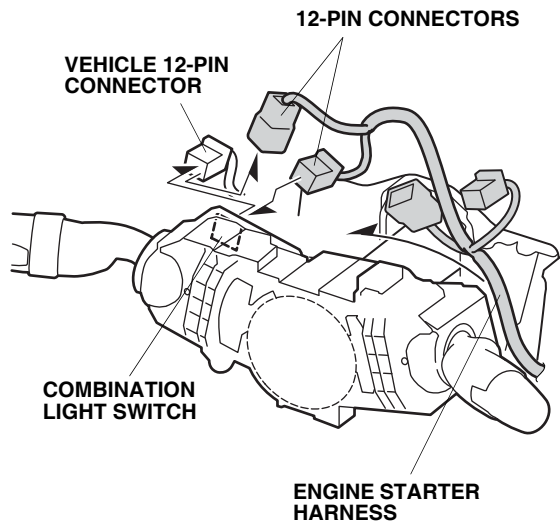

31. Unplug the vehicle 8-pin connector and plug it into the engine starter harness 8-pin connector. Plug the remaining engine starter harness 8-pin connector into the wiper switch.

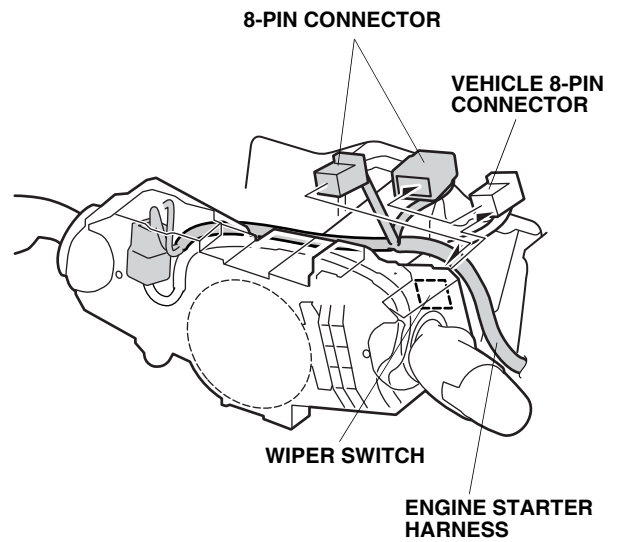

32. Using two wire ties, secure the engine starter harness to the vehicle harness. Do not secure it to the SRS harness.

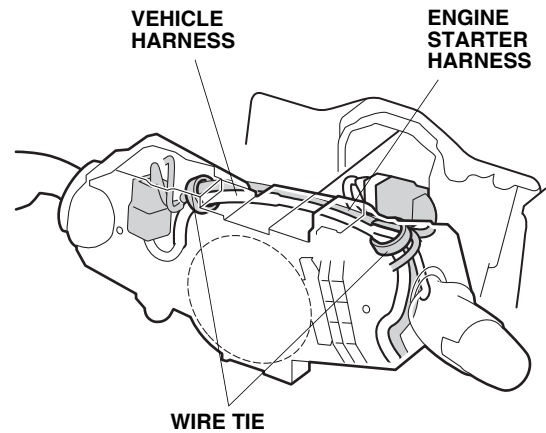

33. Using two wire ties, secure the engine starter harness to the vehicle harness in the areas shown.

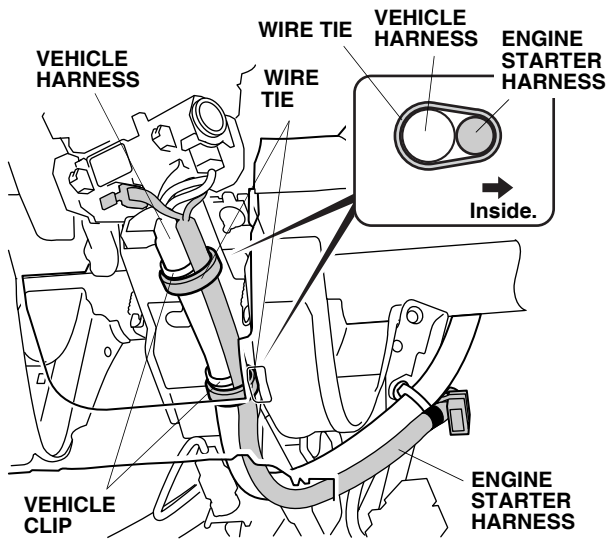

34. Unplug the vehicle 20-pin connector from the vehicle unit removed in step 21, and plug it into the engine starter harness 20-pin connector. Plug the remaining engine starter harness 20-pin connector into the vehicle unit.

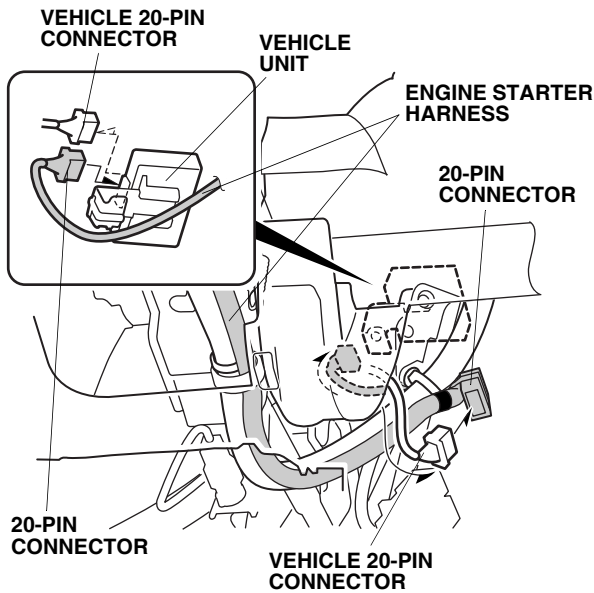

35. Align the green tape on the engine starter harness with the clip on the vehicle harness, and secure the engine starter harness to the vehicle harness using one wire tie.

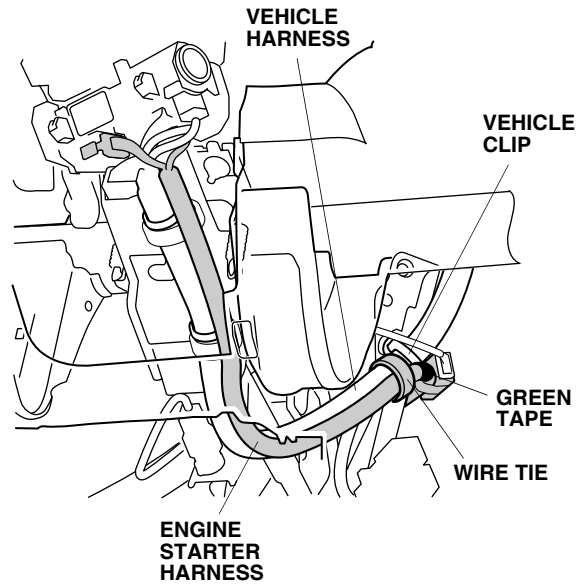

36. Near the connector, secure the engine starter harness to the vehicle harness using one wire tie.

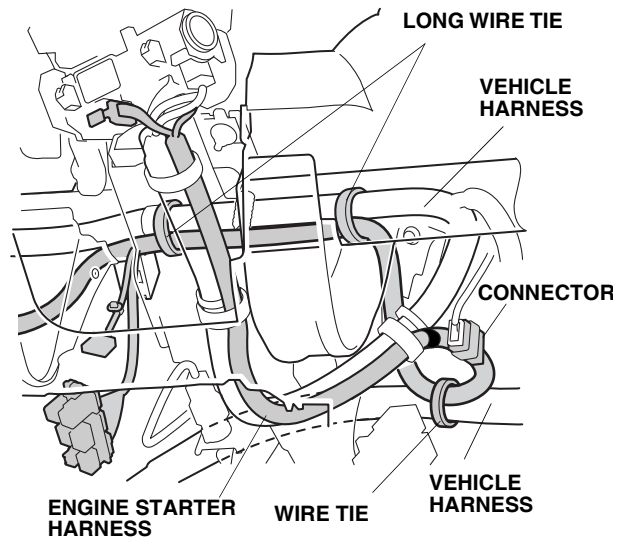

37. Using two long wire ties, secure the engine starter harness to the vehicle harness at the locations shown.

38. Reinstall the vehicle unit to the vehicle bracket using the bolt removed in step 21.

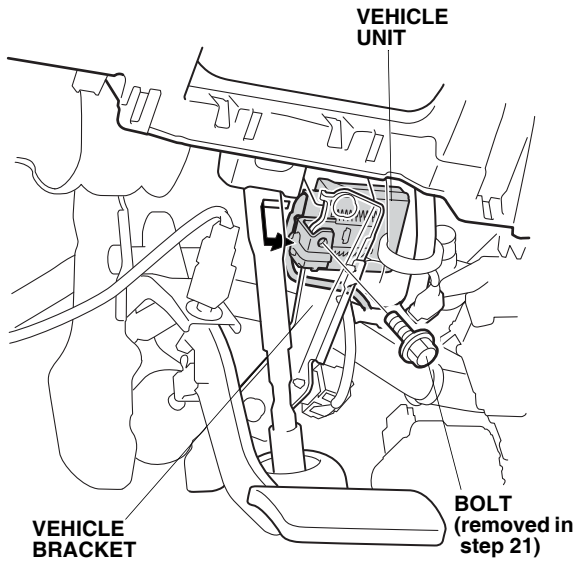

39. Route the engine starter harness along the vehicle harness to the front of the fuse box.

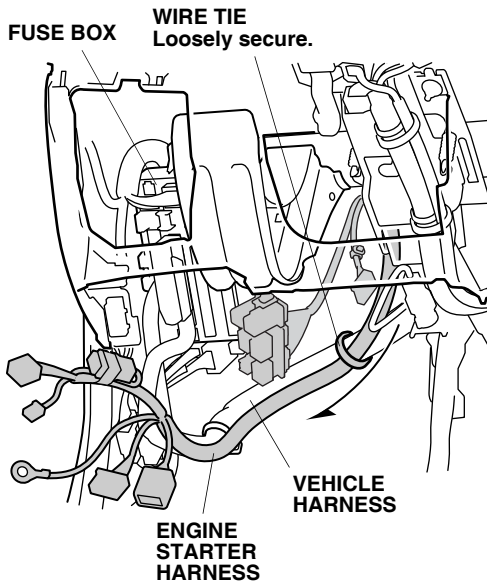

40. Using one wire tie, loosely secure the engine starter harness to the vehicle harness.

41. Unplug the vehicle 5-pin connector from the fuse box. Plug the engine starter harness 5-pin connector into the fuse box 5-pin connector. Wrap one urethane tape around the vehicle 5-pin connector.

NOTICE: Check that the engine starter harness 5-pin connector is securely connected to the fuse box 5-pin connector. A loose connection can cause the engine to stall.

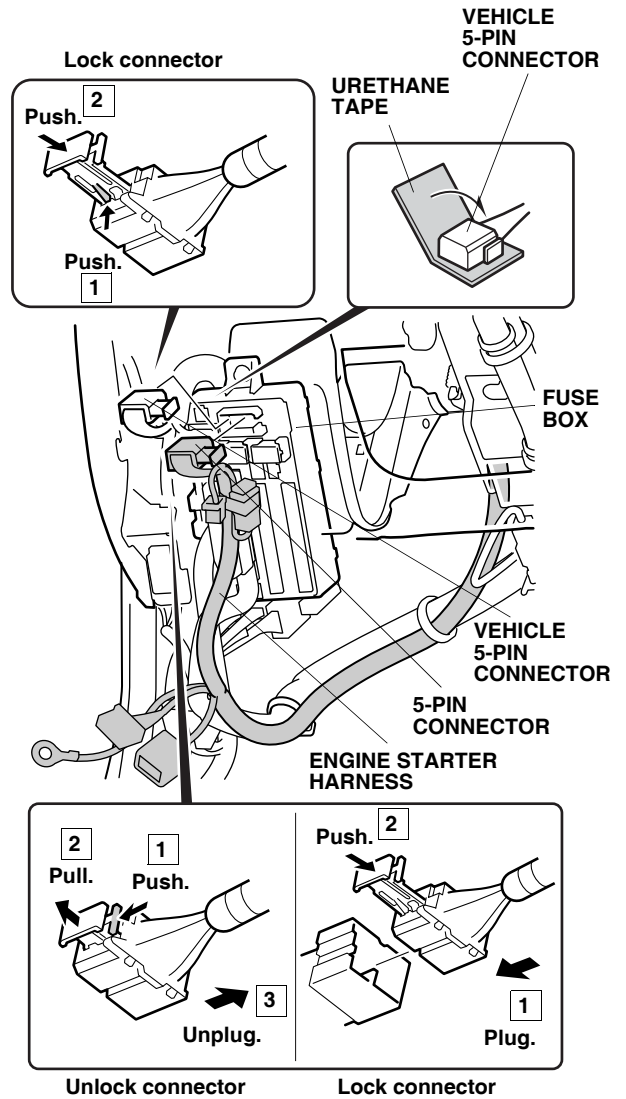

42. Plug the engine starter harness 12-pin connector into the fuse box 12-pin connector.

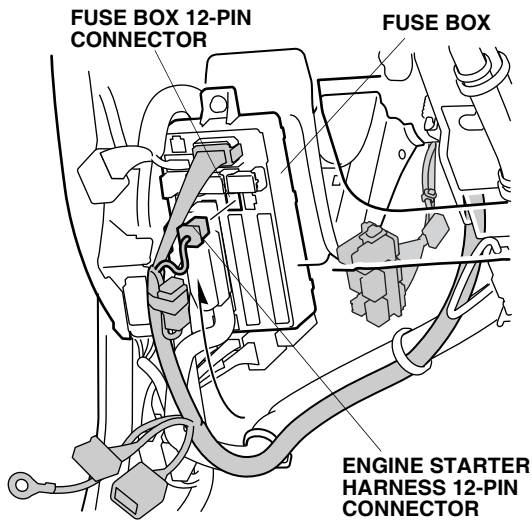

NOTE: If another accessory 12-pin connector is already plugged into the fuse box: Unplug the 12-pin connector from the fuse box, then plug the engine starter harness 12-pin connector into the fuse box. Remove and discard the dummy connector from the engine starter harness, and plug the other accessory 12-pin connector into the engine starter harness 12-pin connector.

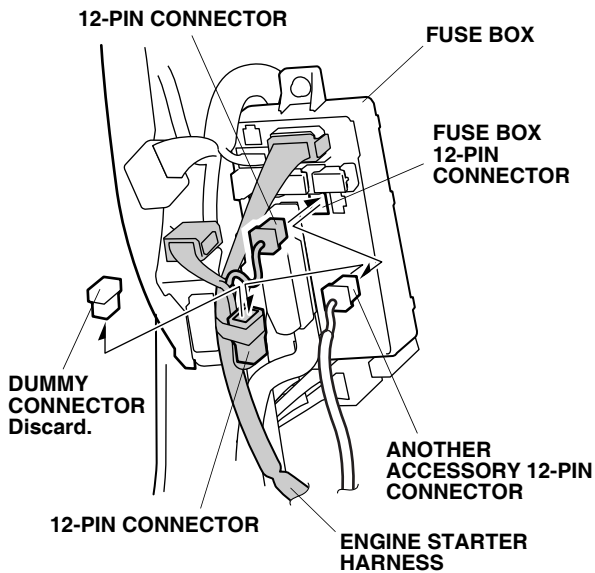

43. Using one wire tie, loosely secure the engine starter harness to the vehicle harness.

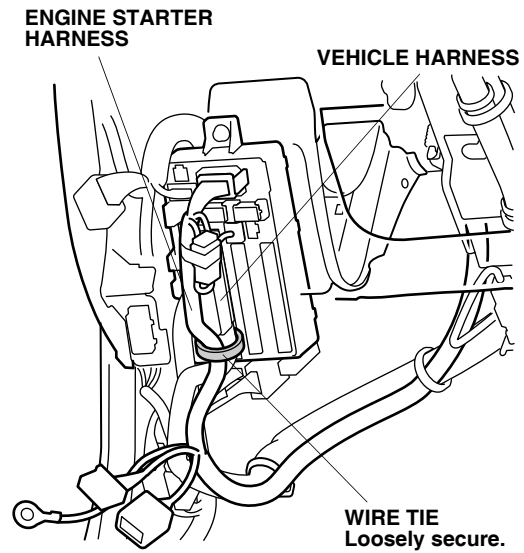

44. Unplug the vehicle 20-pin connector (blue), and plug it into the engine starter harness 20-pin connector. Plug the engine starter harness 20-pin connector (white) into the vehicle 20-pin connector.

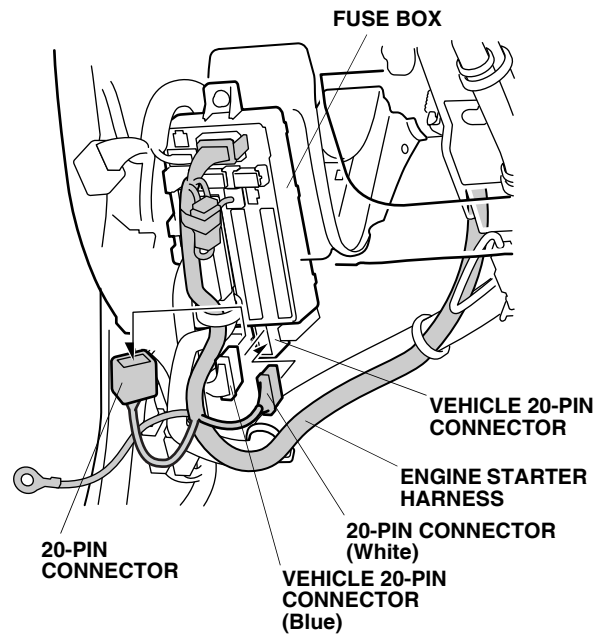

45. Attach the engine starter harness 20-pin connector to the vehicle connector as shown.

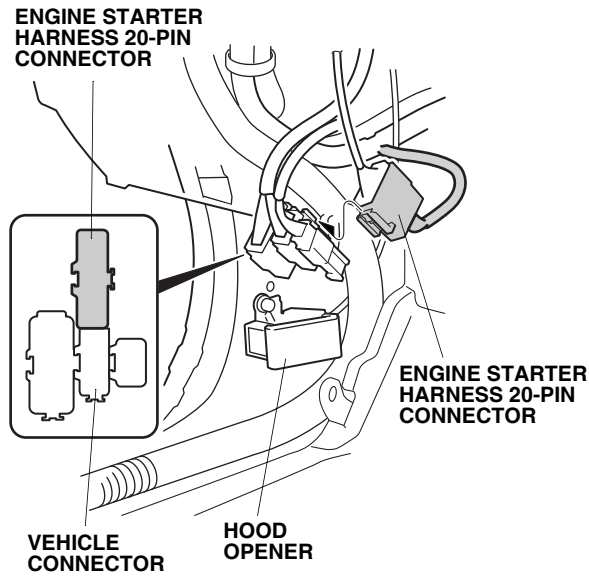

46. Remove and discard the hood opener bolt. Install the ground bolt with the engine starter harness ground terminal attached.

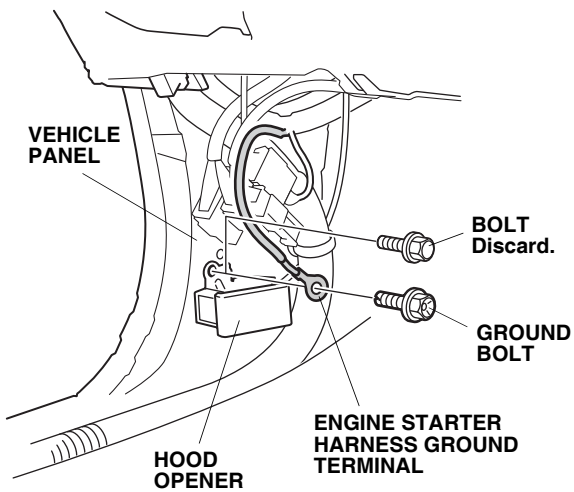

47. Using one wire tie, secure the engine starter harness to the vehicle harness.

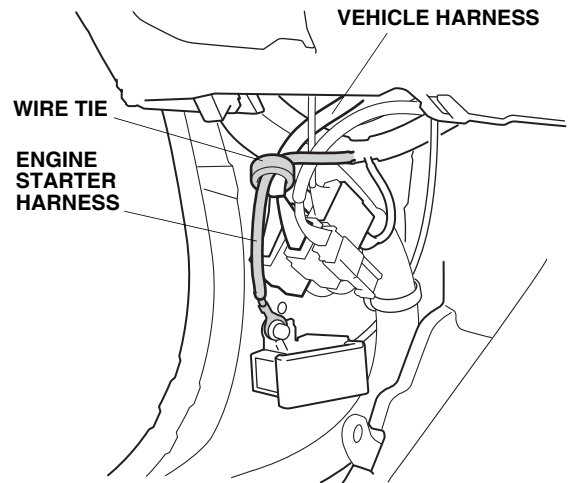

48. Using two wire ties, loosely secure the engine starter harness to the vehicle harness.

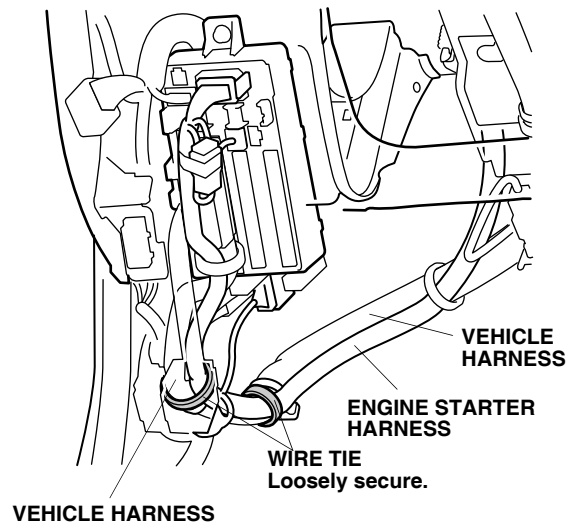

Installing the Antenna

49. Using scissors, cut out the appropriate template.

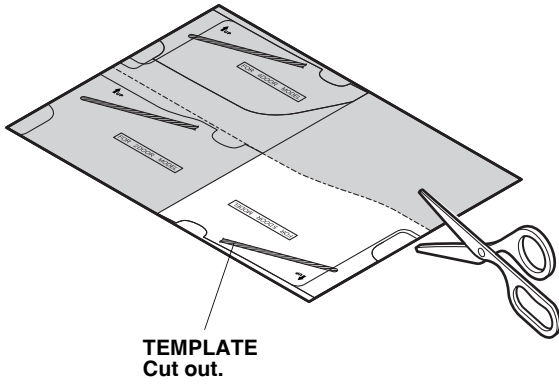

50. Using scissors, trim the template.

EX model:

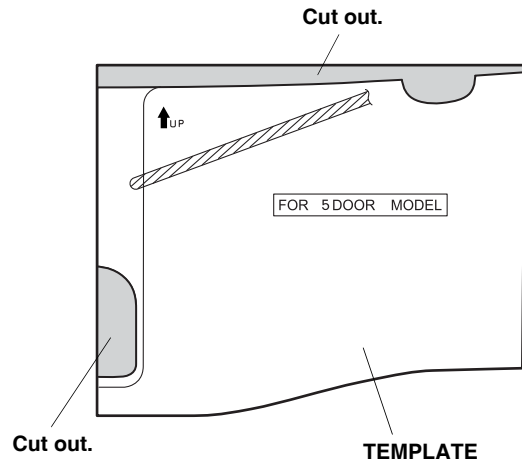

EX-L model:

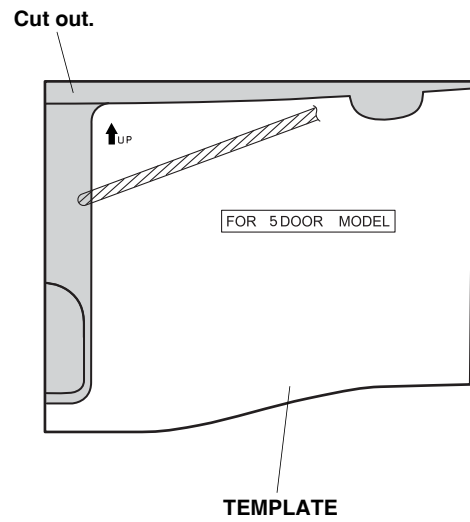

51. Attach the template to the windshield.

EX model:

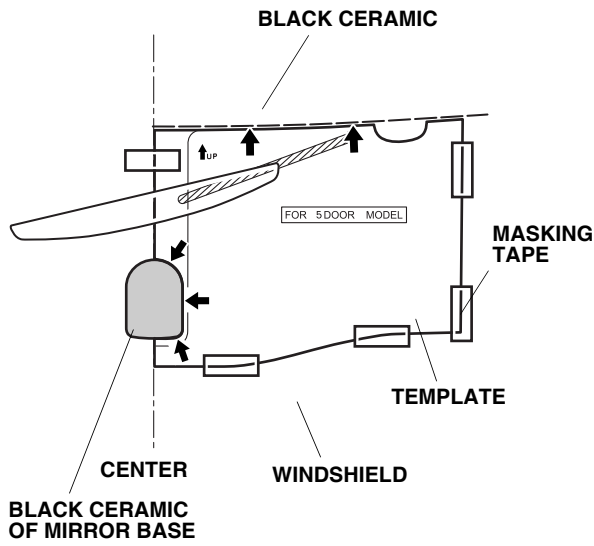

EX-L model:

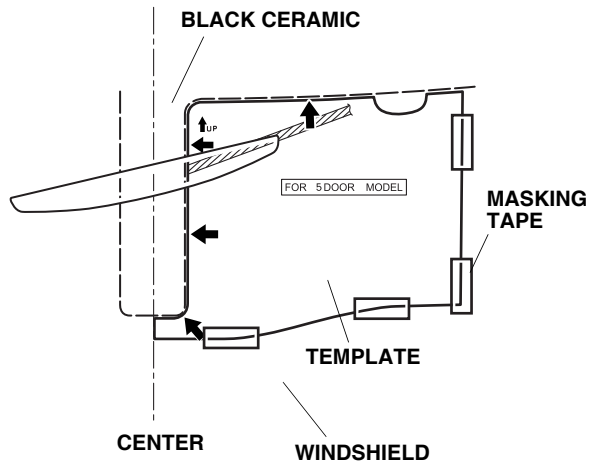

52. Using two pair of needle nose pliers, bend the antenna plate according to the full scale drawing shown.

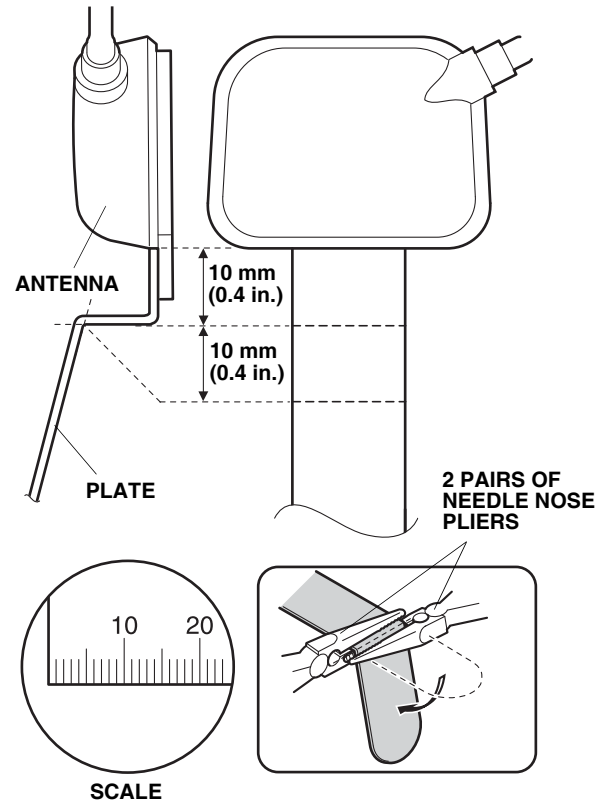

53. Starting at the antenna end of the cable, wrap three urethane tapes around the antenna cable at the measurements shown.

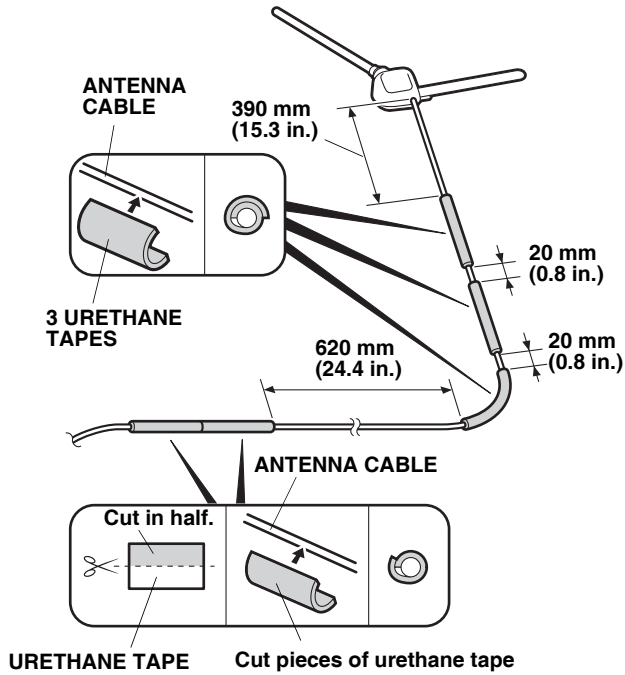

54. Cut one urethane tape in half. Wrap the two cut pieces around the antenna cable at the measurements shown.

55. Using isopropyl alcohol on a shop towel, clean the area where the antenna will attach.

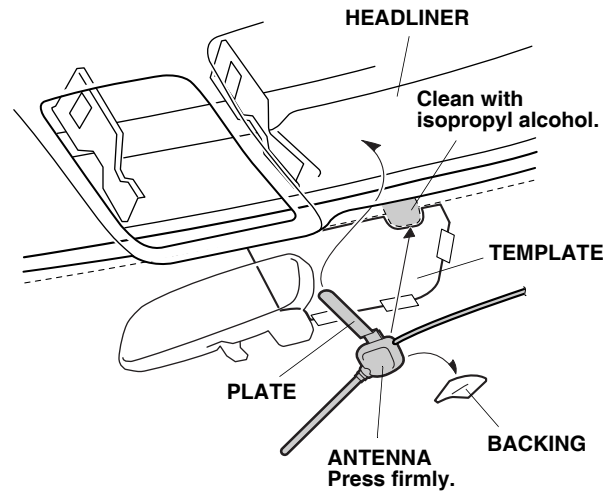

56. Remove the backing from the antenna. Insert the antenna plate under the headliner, align the antenna with the template, and attach the antenna to the windshield. Press the antenna firmly.

NOTE: This antenna should be installed only if the ambient air temperature is 15°C (60°F) or above.

57. Remove the template.
58. Gently pull down the headliner, and tuck the antenna cable under the headliner. Be careful not to crease the headliner.

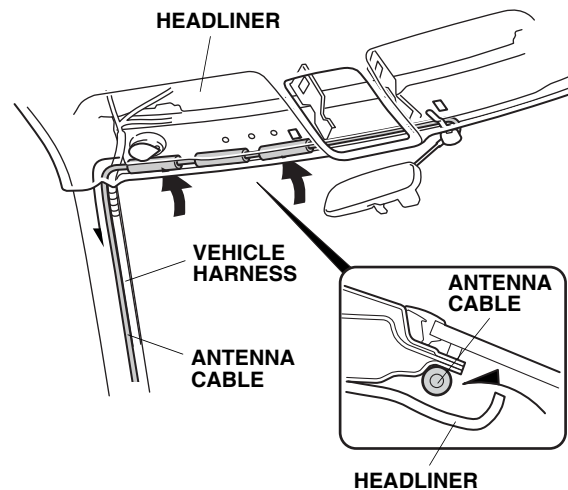

59. Using isopropyl alcohol on a shop towel, clean the areas where the urethane tapes will attach.

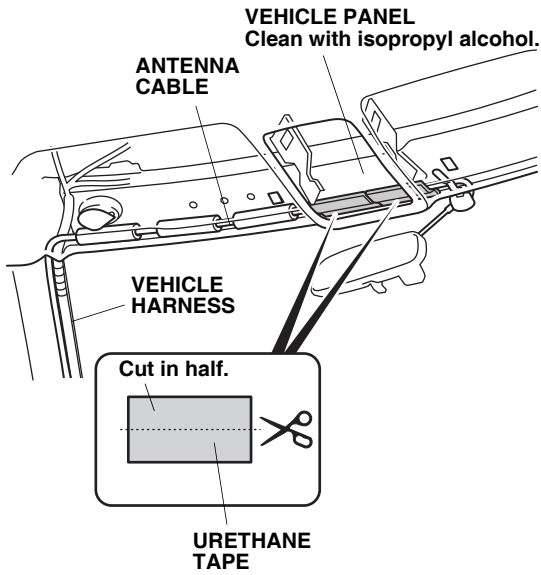

60. Cut one urethane tape in half. Secure the antenna cable to the vehicle panel using the cut pieces of urethane tape.
61. Route the antenna cable down and under the dashboard through the A-pillar trim opening.

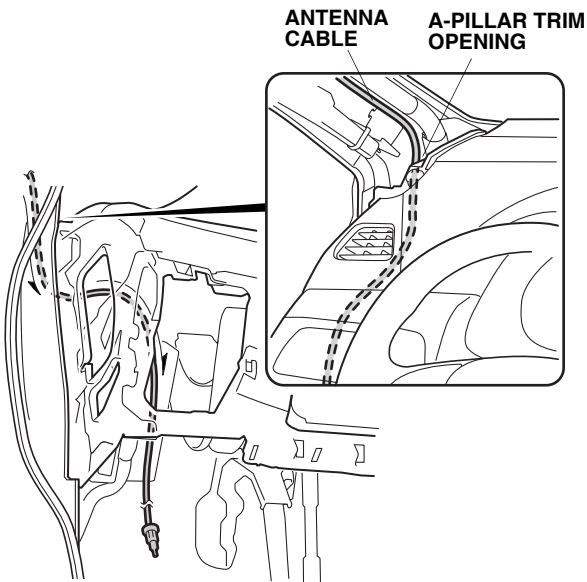

62. Using four wire ties, secure the antenna cable to the vehicle harness.

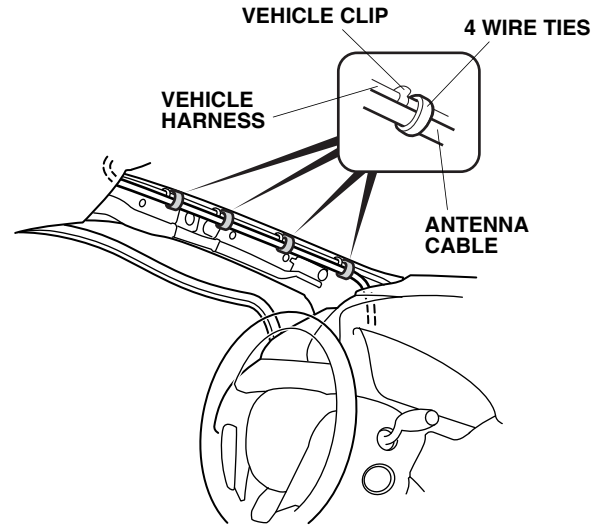

63. Using one wire tie, secure the vehicle 5-pin connector unplugged in step 41 to the vehicle harness.

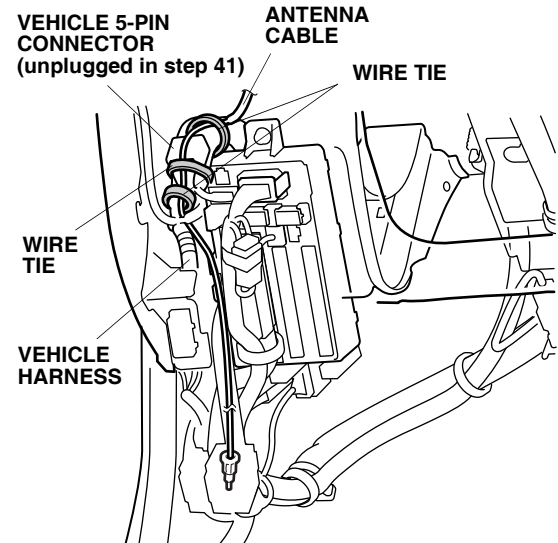

64. Using two wire ties, secure the antenna cable to the vehicle harness.

65. Route the antenna cable along the engine starter harness as shown.

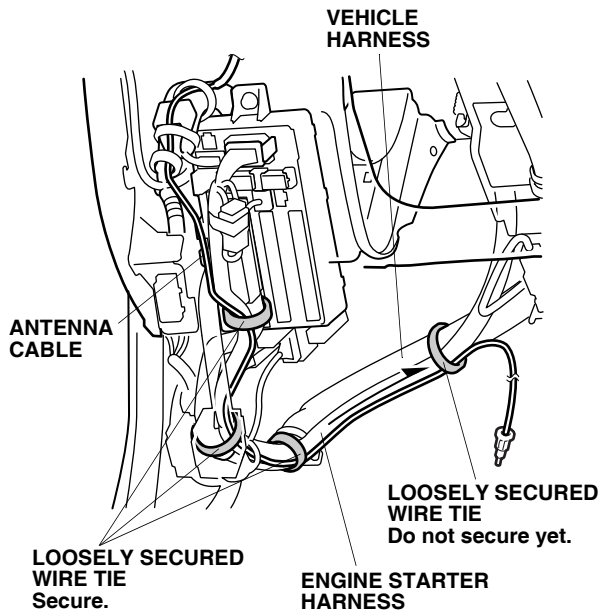

66. Secure the antenna cable using the three loosely secured wire ties.

Installation of the Control Unit

67. Install the control unit bracket to the control unit.

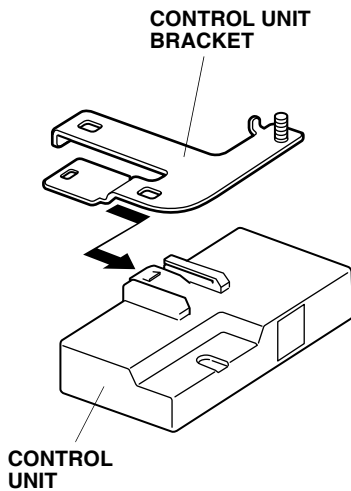

68. Plug the engine starter harness 28-pin connector into the control unit.

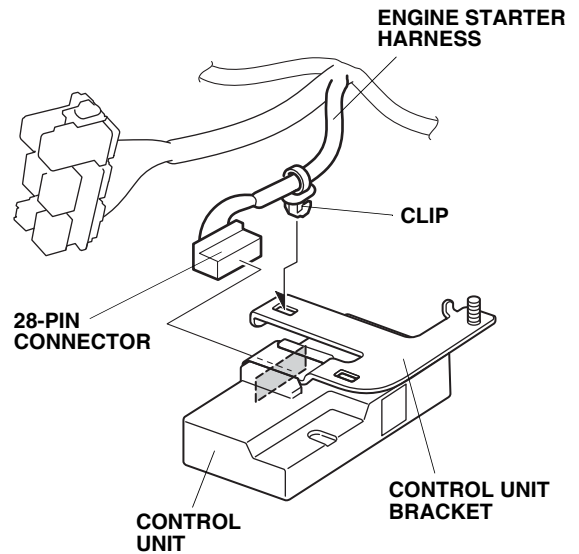

69. Install the clip on the engine starter harness to the control unit bracket.

70. Plug the antenna terminal into the control unit.

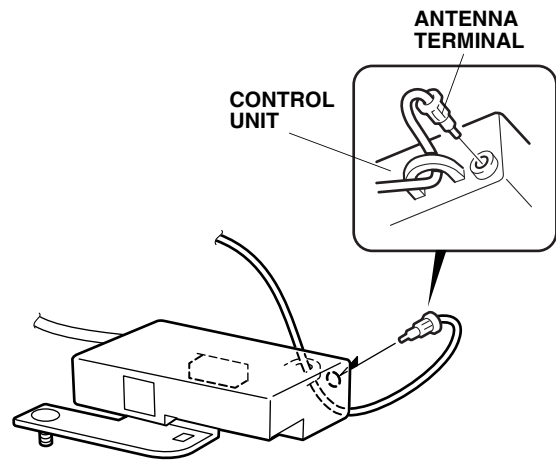

71. Secure the control unit to the vehicle frame using the flange nut.

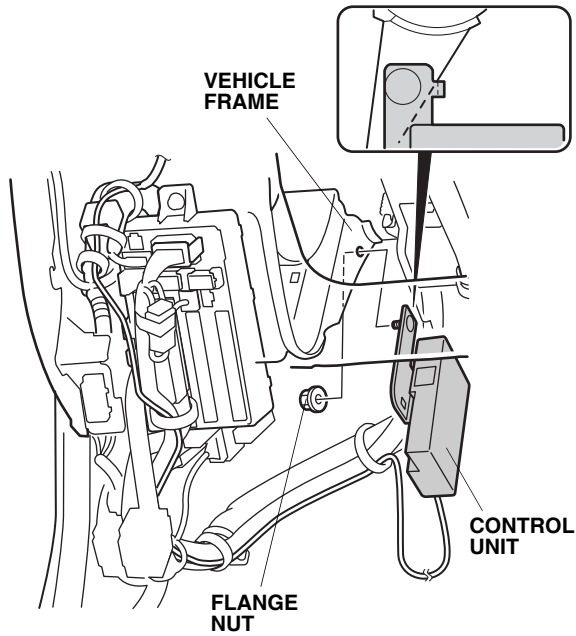

72. Wrap one urethane tape around the vehicle connector.

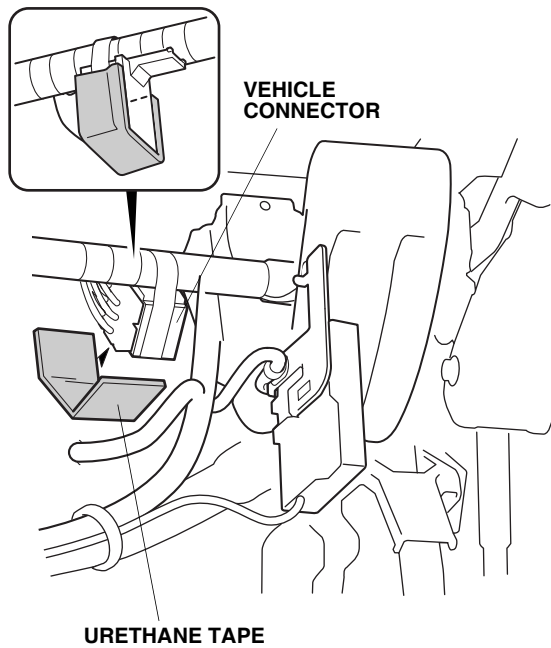

73. Attach the engine starter harness relay block clip to the vehicle frame.

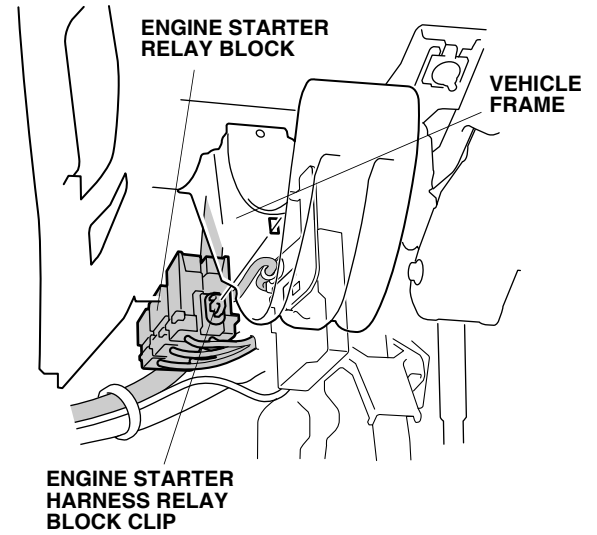

74. Bundle up the excess antenna cable and secure it to the engine starter harness and the vehicle harness using the loosely secured wire tie.

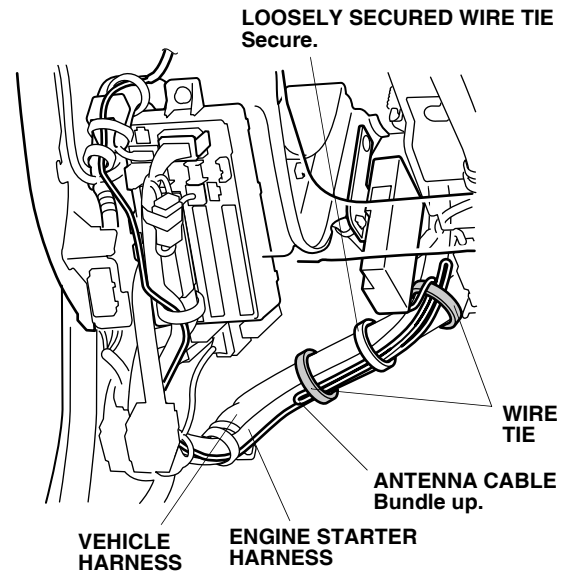

75. Using two wire ties, secure the antenna cable to the engine starter harness.

76. Under the hood, locate the area where the caution label will attach. Using isopropyl alcohol on a shop towel, clean the hood where the caution label will attach.

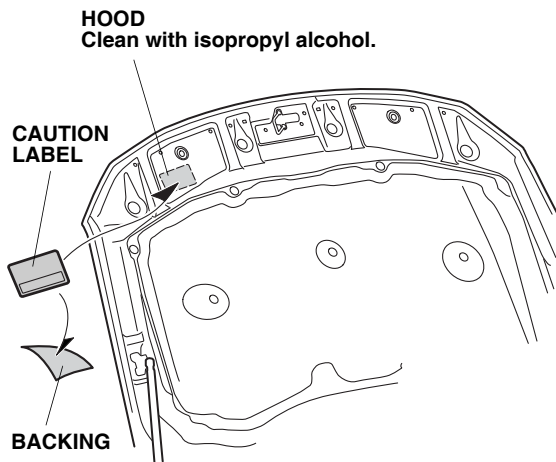

77. Attach the caution label to the hood in the area shown.
78. Reinstall all removed parts. Check that all clips and other fasteners are installed securely. Take care not to pinch the airbag with the clip during reinstallation of the A-pillar trim. Do not push the A-pillar trim excessively.
79. Reconnect the negative cable to the battery.
80. Enter the customer's radio anti-theft code, and reset the radio station presets.
81. Reset the clock.
82. Perform "REMOTE ENGINE STARTER REGISTRATION" and "FUNCTION CHECK."

REMOTE ENGINE STARTER REGISTRATION

1. Acquire the PCM Code from ISIS.

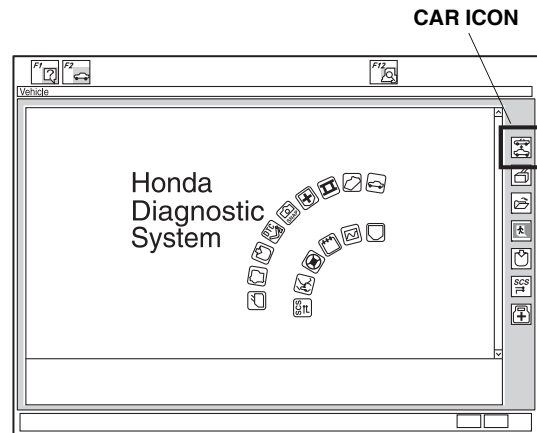

2. Connect the HDS tester to the OBD II data link connector, then turn the ignition switch on.
3. Start the HDS, and click the car icon.
4. Input the VIN and other requirements, then click the check button.

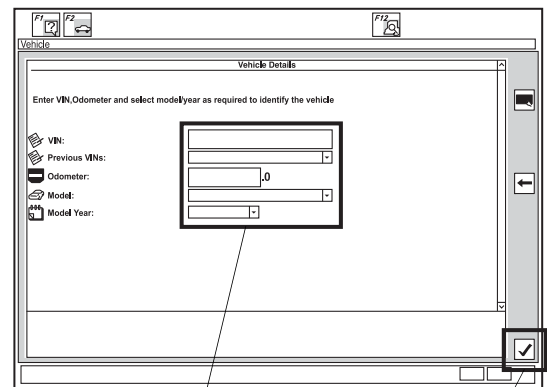

Input the VIN and other requirements.

CHECK BUTTON

5. Select "Honda Systems," then click the check button.

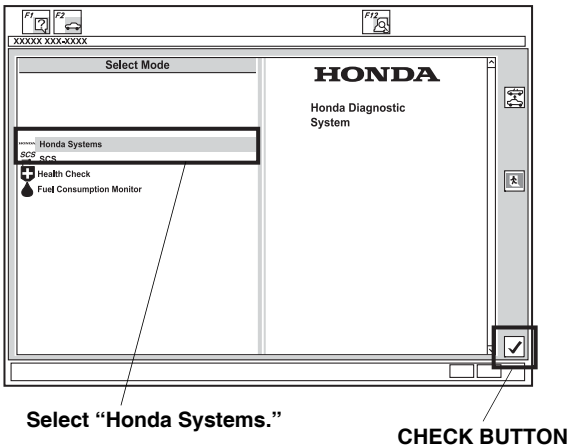

6. Select "R/C ENG STARTER," and click the check button.

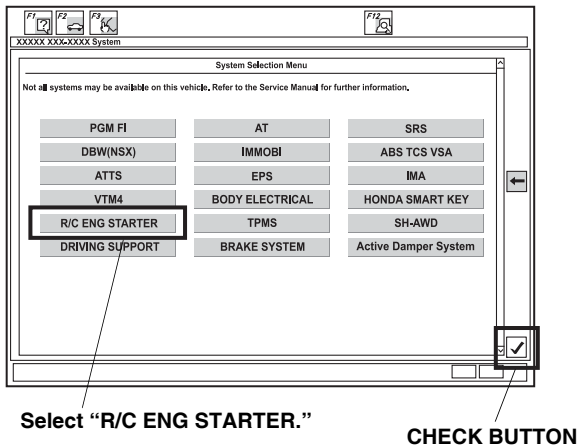

7. Check that "REMARKS" is shown, then click the check button.

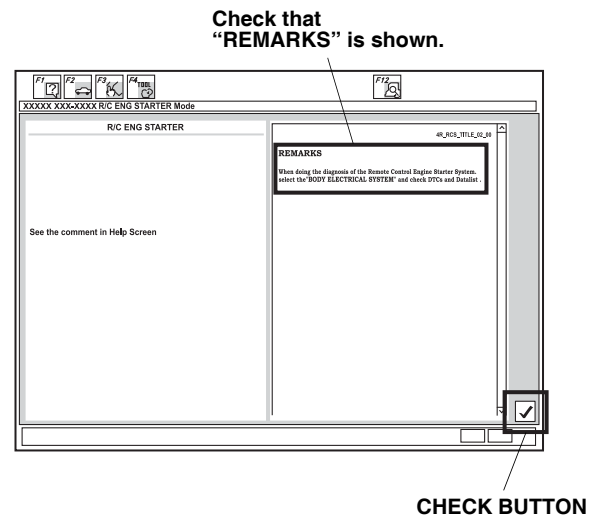

8. Select "REGISTER REMOTE CONTROL ENGINE STARTER UNIT," then click the check button.

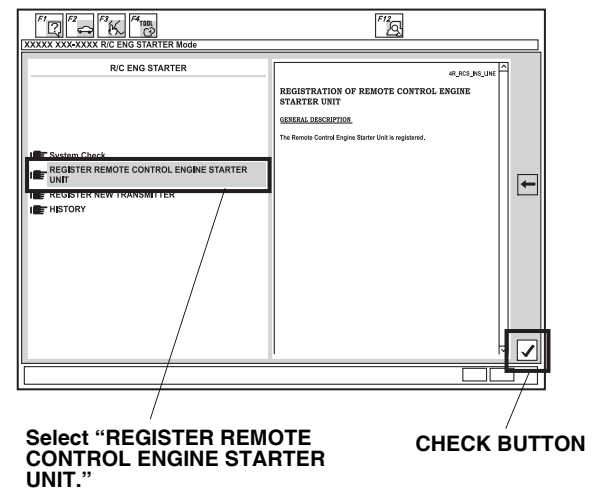

9. Check that “Obtain PCM-code (IMMOBILIZER PCM CODE) from iN. This vehicle’s VIN will be required to obtain the password. (USA)” is shown, then click the check button.

Check that “Obtain PCM-code (IMMOBILIZER PCM CODE) from iN. This vehicle’s VIN will be required to obtain the password. (USA)” is shown.

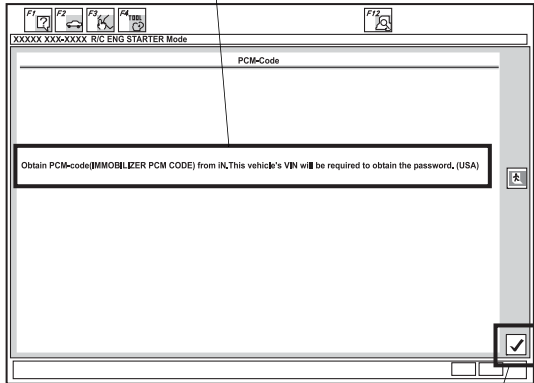

CHECK BUTTON

10. Input the PCM Code, then click the check button.
NOTE: To ensure security, the PCM code (password) is changed everyday, so it is impossible to register the remote controlled engine starter if the date of the PCM code acquisition and registration are different. The date of the HDS tester should also be the same.

Input the PCM Code.

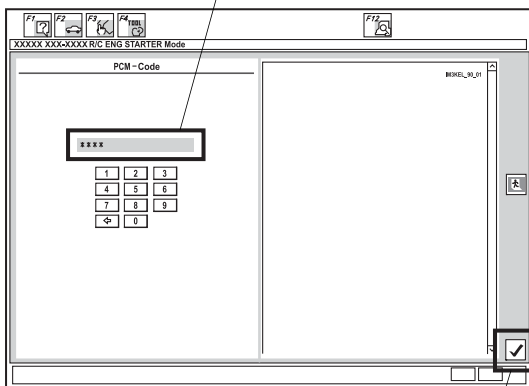

CHECK BUTTON

11. Check that “The registration of the Remote Control Engine Starter Unit has been completed” is shown, then click the check button.

Check that “The registration of the Remote Control Engine Starter Unit has been completed” is shown.

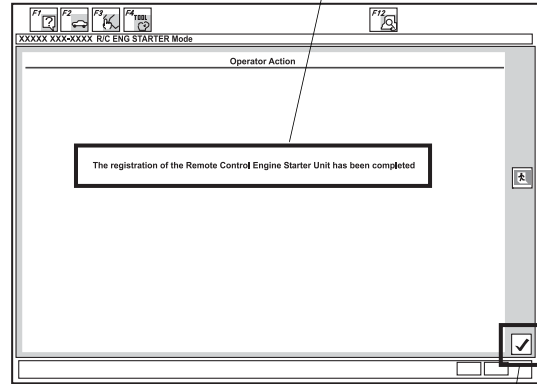

CHECK BUTTON

12. Check that “Check that the engine can be started by the Transmitter” is shown, then click the check button.

Check that “Check that the engine can be started by the Transmitter” is shown.

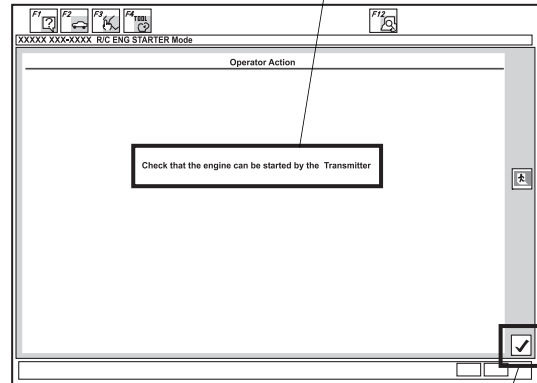

CHECK BUTTON

13. Perform the function test on the next page, then remove the HDS.

FUNCTION CHECK

Operating Conditions

- Hood is closed
- Shift lever in park
- Parking brake is on
- The key is out of the ignition
- All doors and tailgate closed and locked

Inspection

1. Press the command button, and then, within 1 second, press the start button on the transmitter.
The engine should start if all operating conditions are met.

Does the engine start?

Yes - Operation is normal.

No:

- | |
|--|
| <ul style="list-style-type: none">• Make sure all "Operating Conditions" are met.• Check the engine starter harness connections.• Connect the HDS and check for an indicated failure. (Refer to the appropriate service manual for details.) |
|--|

2. Press the command button on the transmitter, and, within 1 second, press the stop button. The engine should stop.

Does the engine stop?

Yes - Operation is normal.

No - Check the engine starter harness connections.
--

3. After the engine has stopped, start the engine again and, check that the engine stops after each of the following conditions:

NOTE: After each test, the ignition key must be cycled, or the driver's door must be opened and closed.

- Move the shift lever out of the P position.
- Unlock or open the doors or the tailgate.
- Open the hood.
- Insert the key in the ignition.
- Press on the brake pedal.

Does the engine stop after each of these tests?

Yes - Operation is normal.

No - Check the engine starter harness connections.
--

4. Check that the power windows and the moonroof do not function when the engine is started with the transmitter.
5. Press the command button on the transmitter two times and check the vehicle condition on the display.
6. Check the operation of the transmitter when the vehicle is 100 m to 150 m (325 to 490 ft.) away, and in direct sight.

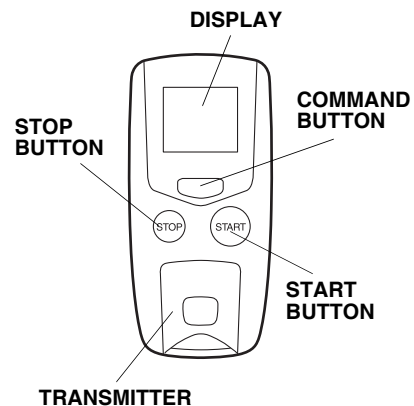

How to Program an Additional Transmitter

1. Connect the HDS to the data link connector.
2. Start the HDS and click on the car icon.
3. Input the vehicles's VIN and other required information.
4. Select **Honda System**.
5. Select **R/C Engine Starter**.
6. Select **REGISTER NEW TRANSMITTER**.
7. When "Ready to program the new transmitter" shows, select **ENTER**.
8. Press and release the Command button.
9. Press and release the Stop button.
10. Perform the function check on both transmitters.

NOTE: Only 2 remotes can be stored in the system's memory.