



# INSTALLATION INSTRUCTIONS

Accessory  
**ENGINE BLOCK HEATER**

Application  
**2012 CR-Z**

Publications No.  
**All 46895**

Issue Date  
**OCT 2011**

## PARTS LIST

**Engine Block Heater Kit  
P/N 08T44-SNA-101**

Engine block heater

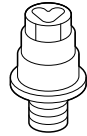

Aluminum washer



Heater harness

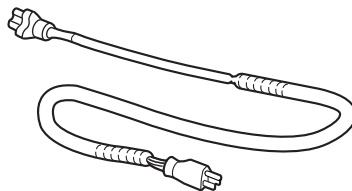

Protective cap

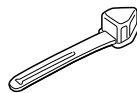

12 Black wire ties  
(4 Not used)

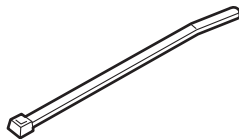

7 Wire ties with clips  
(3 Not used)

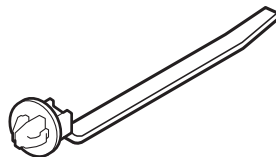

5 White wire ties  
(Not used)

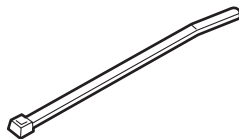

**Engine Block Heater Bracket Kit  
P/N 08T44-TK6-100**

Engine block heater bracket



Washer-bolt, 6 x 12 mm

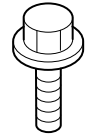

## TOOLS AND SUPPLIES REQUIRED

Ratchet

12 mm, 19 mm, and 24 mm Sockets

10 mm Open end wrench

Torque wrench

Diagonal cutters

Heavy gloves

Drain pan

Tape measure

White marker

Coolant (Honda All Season Antifreeze/Coolant Type 2)

Fender cover

Phillips screwdriver

Blanket

Trim Tool Set (SOJATP2014)

(Available through the Honda Tool and Equipment program. On the iN, click on: Service/Service Bay/Tool and Equipment Program, then enter the number under "Search." Or call 888-424-6857.)

## Illustration of the Engine Block Heater Installed in the Vehicle

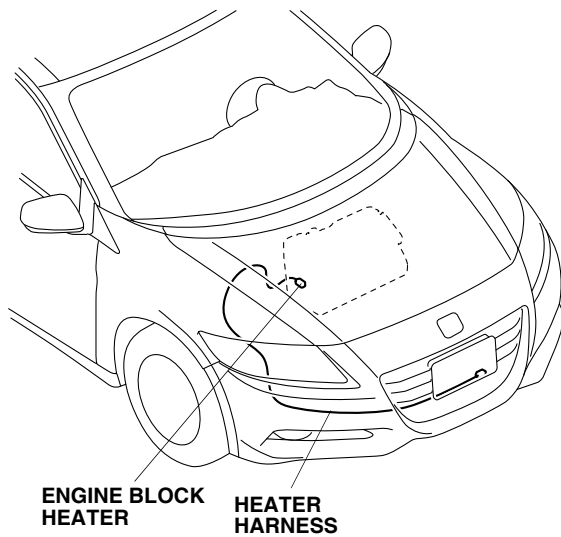

## INSTALLATION

### NOTE:

- Always use Honda All Season Antifreeze/Coolant Type 2. Using a non-Honda coolant may result in corrosion, causing the cooling system to malfunction or fail.
- To avoid burning out the element, do not operate the engine block heater until it is installed on the vehicle and you have added the coolant.

**Customer Information:** The information in this installation instruction is intended for use only by skilled technicians who have the proper tools, equipment, and training to correctly and safely add equipment to your vehicle. These procedures should not be attempted by “do-it-yourselfers.”

1. Make sure you have the anti-theft code for the audio unit and navigation unit (if equipped), then write down the radio station presets.
2. Disconnect the negative cable from the battery.
3. Allow the engine and all cooling system components to cool down.
4. Place the vehicle on a hoist and raise the vehicle off the ground.

5. Remove the front bumper.
  - Remove the front bumper molding (six clips).

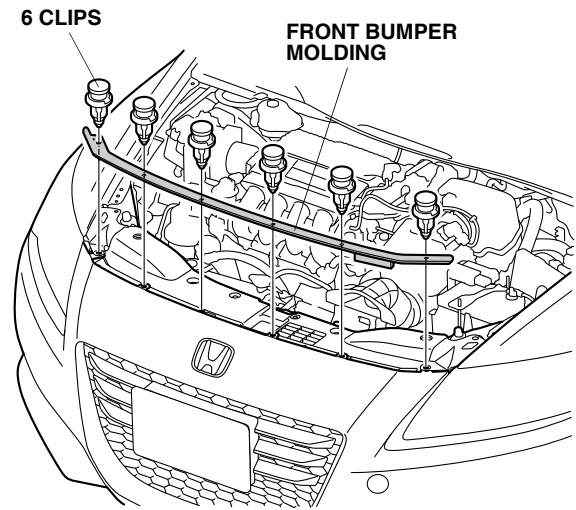

- Remove ten clips, four self-tapping screws, and two washer-screws.

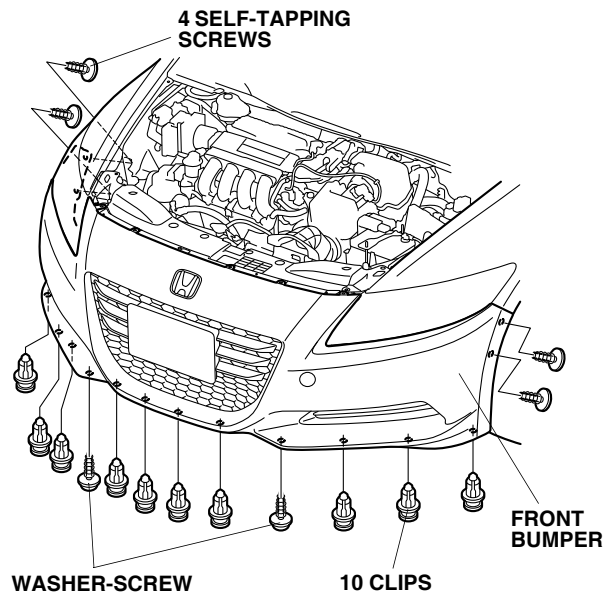

- Remove the top clip. With the help of an assistant, release the six retaining tabs on each side and remove the front bumper.
- If the vehicle is equipped with fog lights, unplug the vehicle connectors.
- Place the front bumper on a blanket.

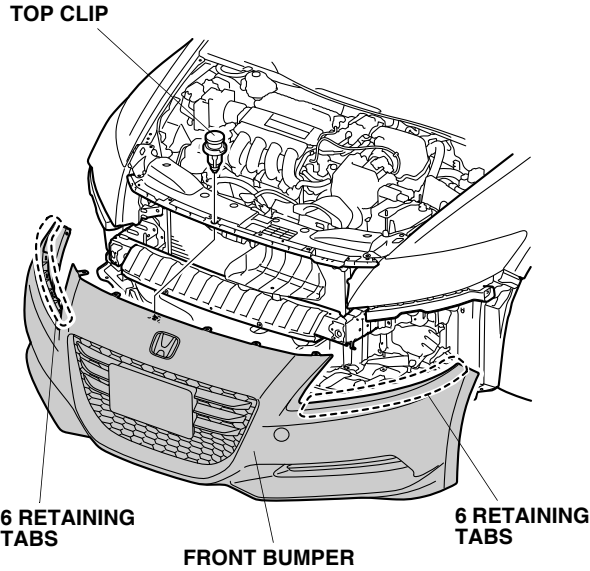

6. Remove the front bulkhead lower cover (four self-tapping screws and seven clips).

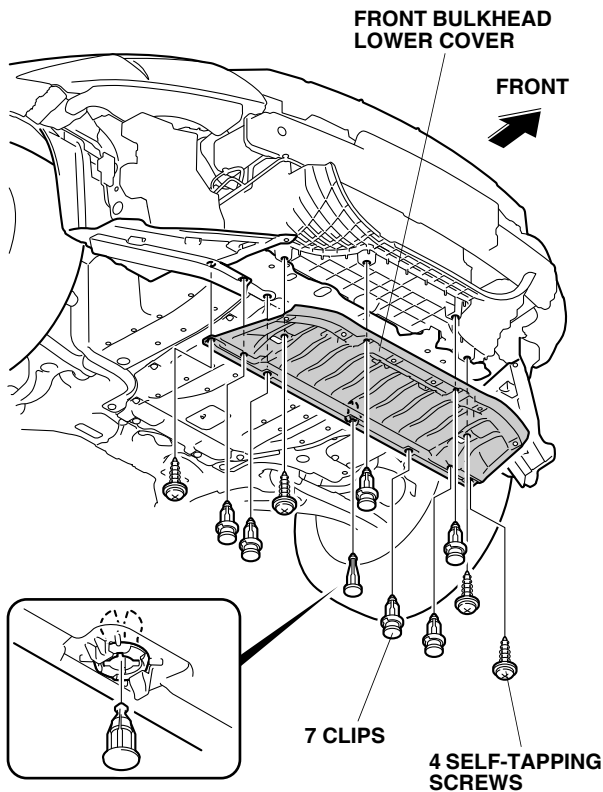

7. Remove the engine under cover (six self-tapping screws and four clips).

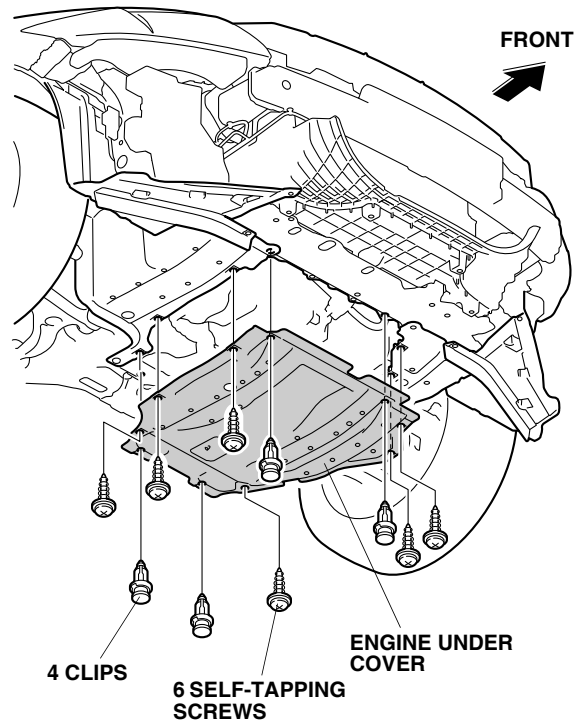

8. Remove the passenger's splash shield (three clips).



9. Place a clean drain pan under the radiator drain plug, then remove the drain plug from the bottom of the radiator to drain the coolant. Remove the radiator cap to increase the flow.

**NOTICE:** Radiator coolant will damage the paint. Quickly rinse any spilled coolant from the paint finish.

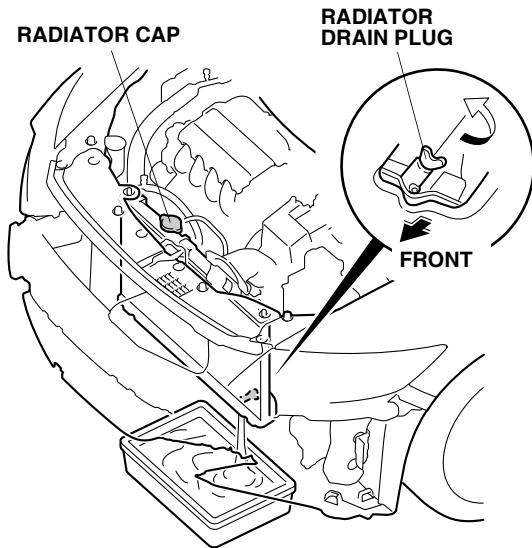

10. Locate and remove the engine block drain bolt and the washer. Coolant remaining in the engine jackets will flow out of the bolt hole when the bolt is removed. Retain the bolt; it will be used if the block heater is removed.

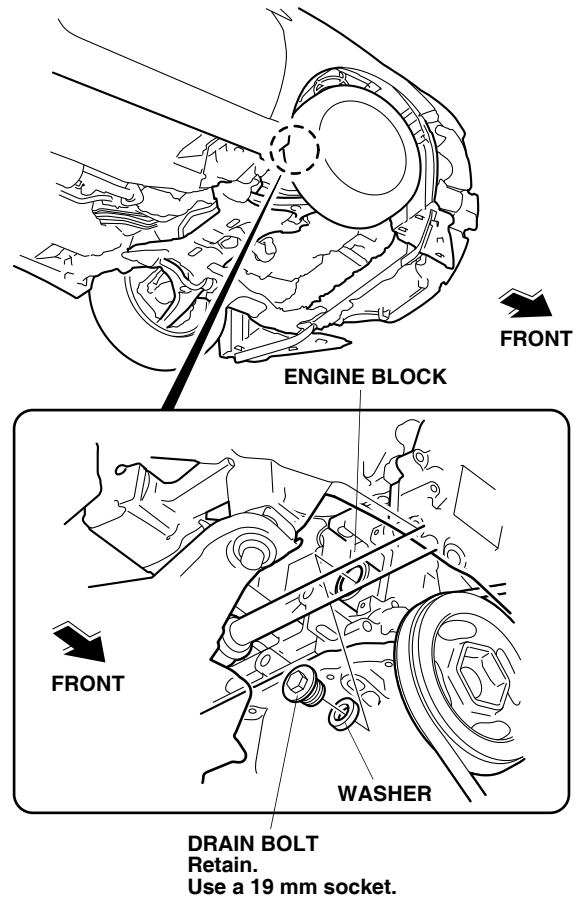

- Install the engine block heater with the aluminum washer into the bolt hole using a 24 mm socket and a torque wrench. Torque the engine block heater to 60 N·m (44 lbf·ft).

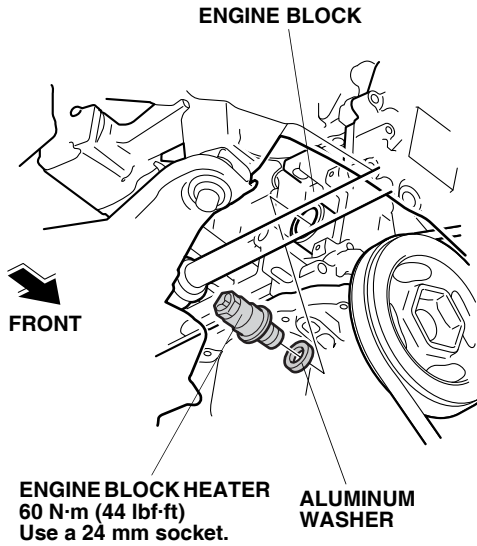

- Attach the engine block heater bracket to the engine block with one 6 x 12 mm washer-bolt.

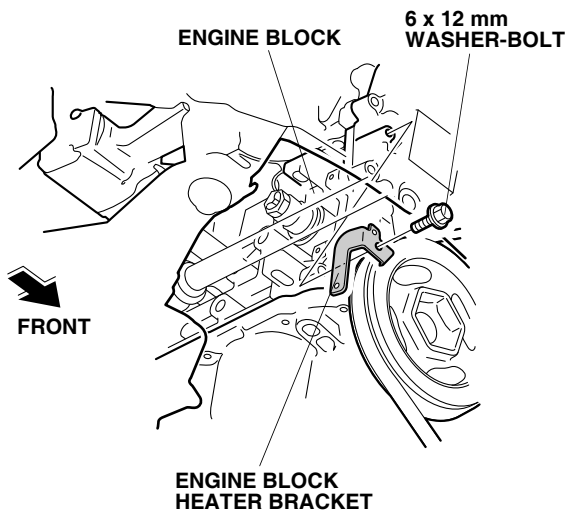

- Using a tape measure, install three wire ties with clips to the heater harness at the measurements shown.

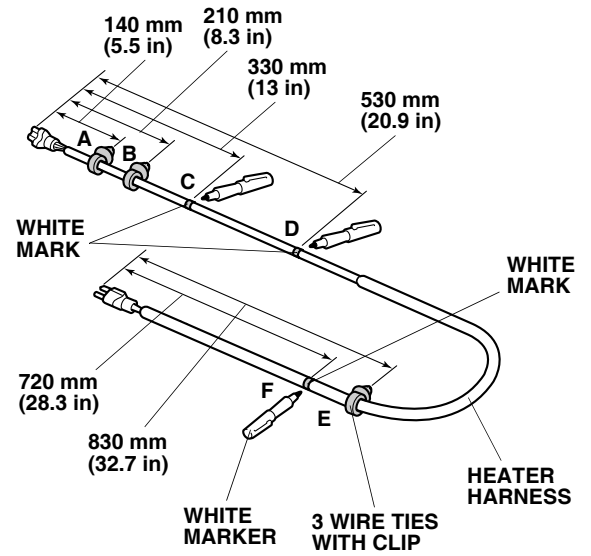

- Using a white marker, mark the heater harness at the three positions shown.
- Plug the connector end of the heater harness into the engine block heater.

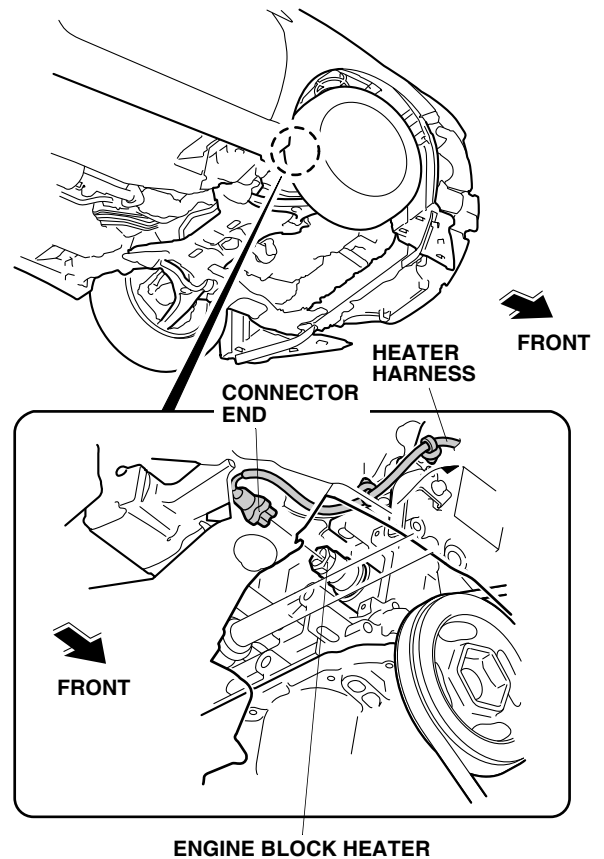

16. Route the heater harness along the engine block, and secure it to the engine block heater bracket with two wire ties with clips at point A and point B.

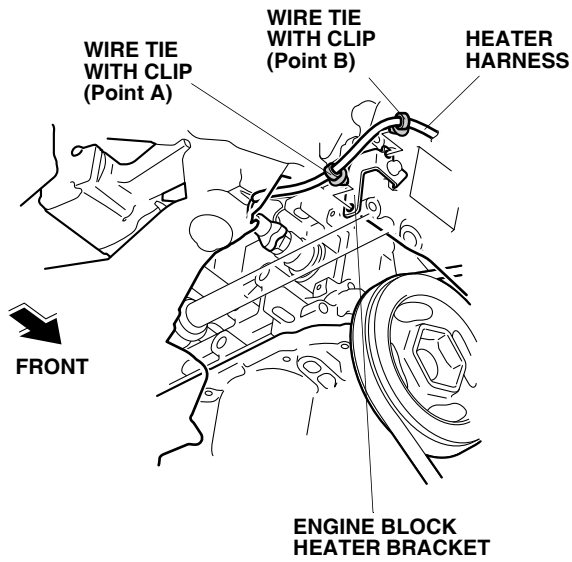

17. Route the heater harness through the engine compartment as shown.

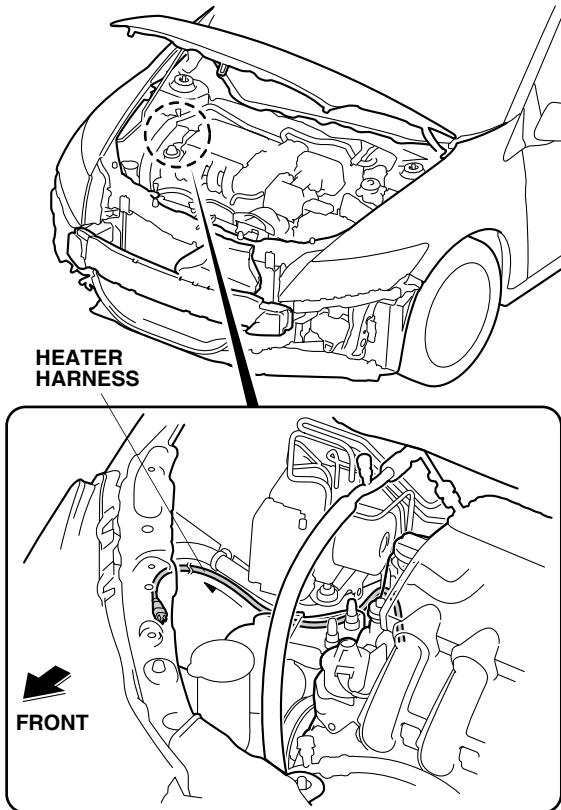

18. Secure the heater harness to the vehicle frame with one wire tie at point C.

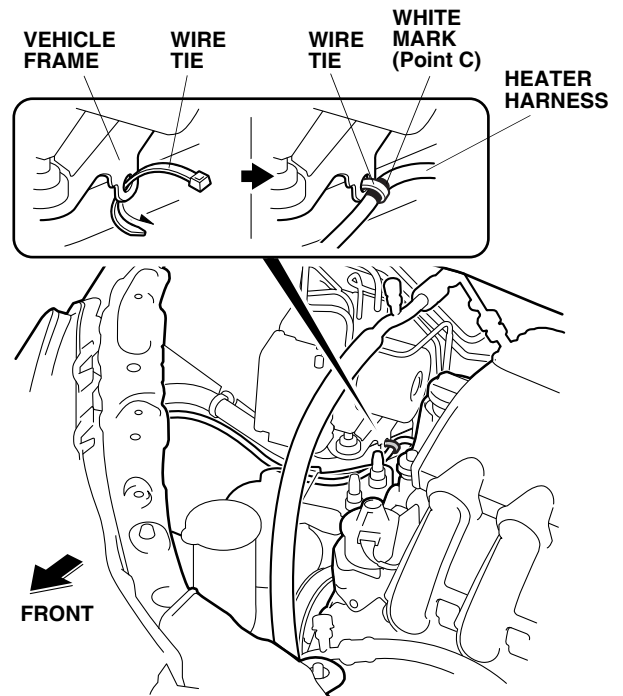

19. Align the white mark at point D to the vehicle clip, and secure the heater harness to the vehicle harness with two wire ties.

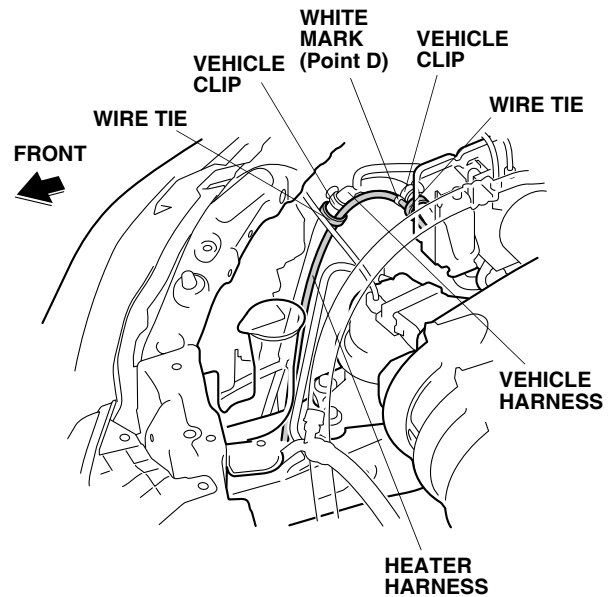

20. Route the heater harness forward, and secure it to the vehicle harness with one wire tie. Do not secure the heater harness to the SRS harness.

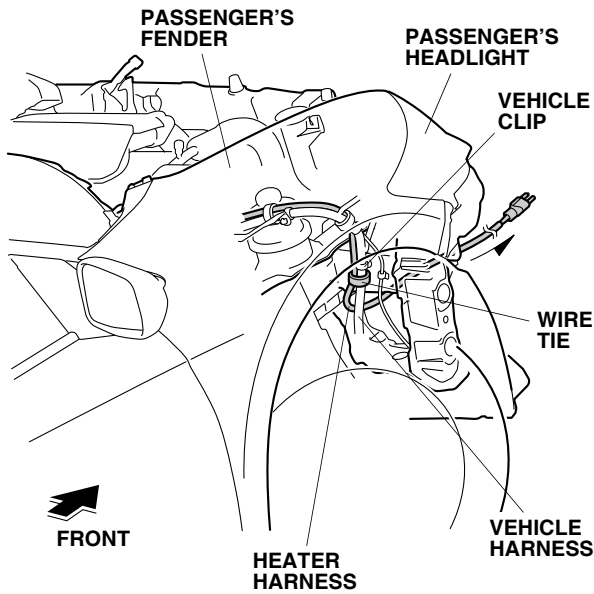

21. Route the heater harness along the front of the vehicle, and secure it to the vehicle frame with one wire tie with clip at point E.

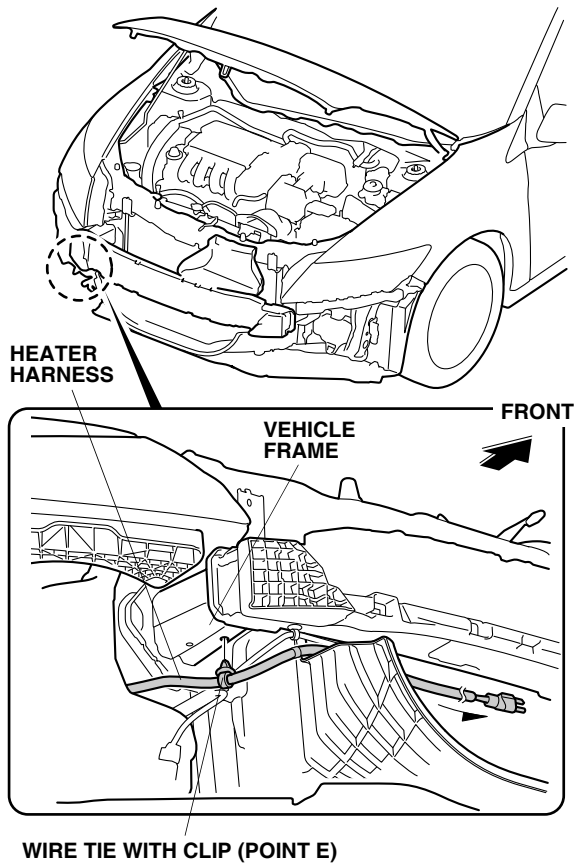

22. Secure the heater harness to the slot in the washer reservoir.

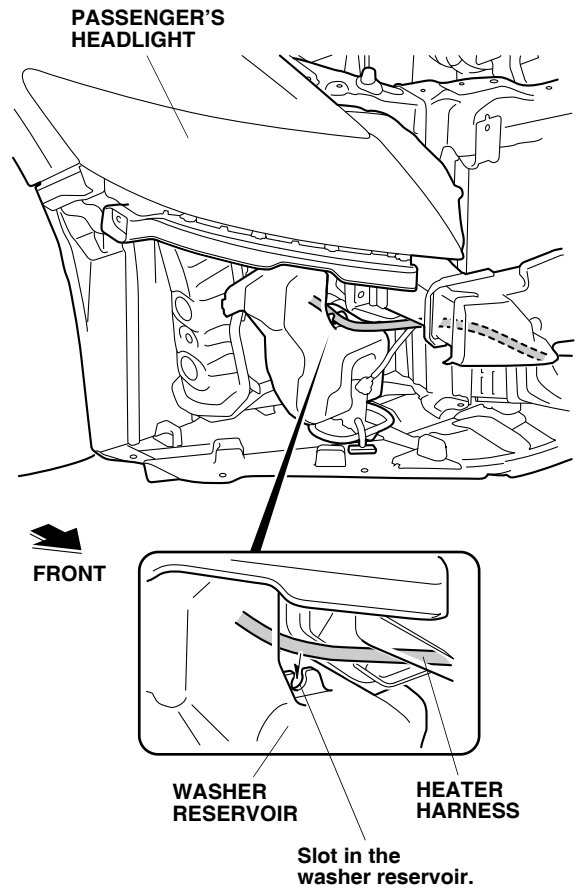

23. Align the white mark at point F to the vehicle clip on the front bumper beam cover. Secure the heater harness to the vehicle harness with one wire tie.

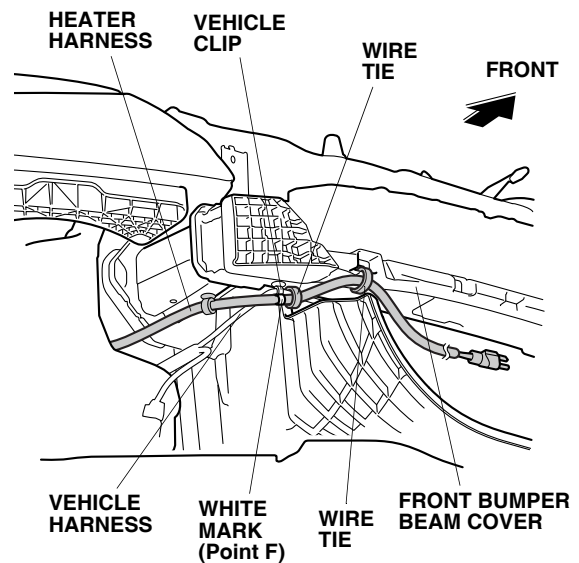

24. Secure the heater harness to the front bumper beam cover with one wire tie.



25. Using diagonal cutters, cut the front grille at the location shown. Remove any burrs.

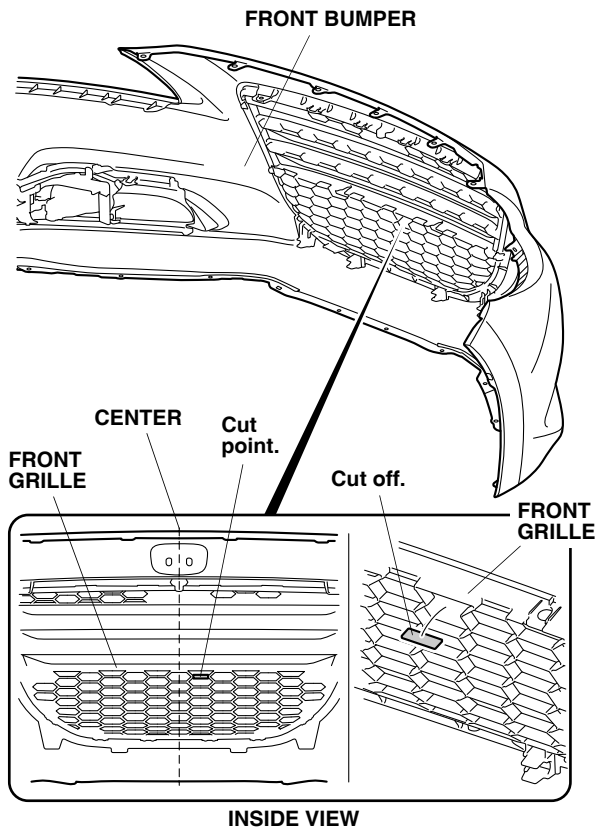

26. With the help of an assistant, loosely place the front bumper in its original position.

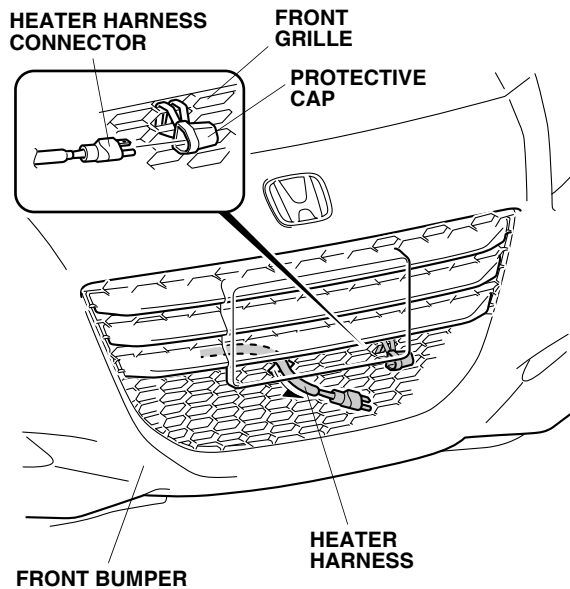

27. Attach the protective cap to the front grille, and plug the heater harness connector into the protective cap.

28. Secure the heater harness to the front grille with two wire ties.

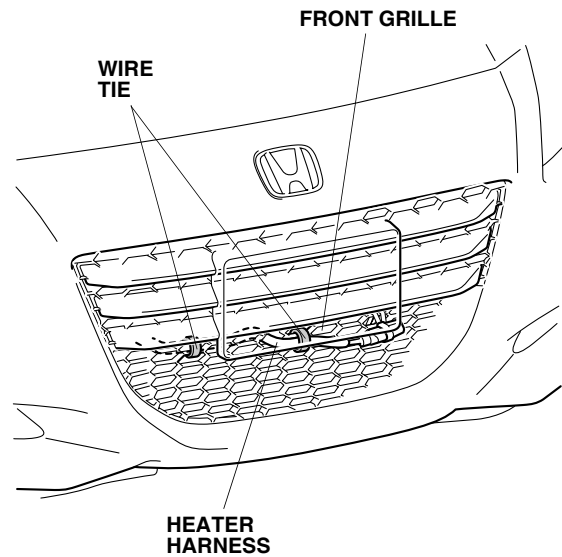

29. Reinstall all removed parts, except for the radiator cap.
30. Fill the system with the recommended coolant. Follow the instructions described in the service manual to fill and bleed the cooling system.
31. Check the coolant reservoir for correct level and check the cooling system for signs of leakage. Repair as necessary.
32. Check that the heater harness is routed properly and all connectors are plugged in.
33. Put the drain bolt (removed in step 10) in the glove box.
34. Enter the customer's anti-theft code for the audio unit and navigation system (if equipped), and reset the radio station presets.
35. Reset the clock.
36. If the IMA battery level gauge display is at zero, start the engine, and hold it between 3,500 rpm and 4,000 rpm (without load) in P or N position until the IMA battery level gauge display shows at least half-charged.