



INSTALLATION INSTRUCTIONS

Accessory
CARGO MANAGEMENT SYSTEM
P/N: 08U35-TA0-100

Application
2012 ACCORD 4-DOOR

Publications No.
All 46530
Issue Date
AUG 2011

PARTS LIST

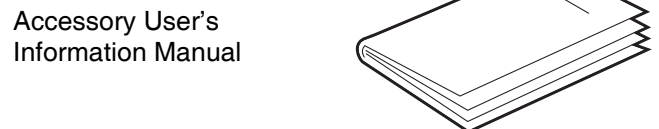
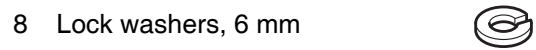
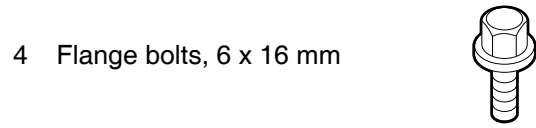
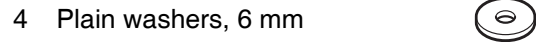
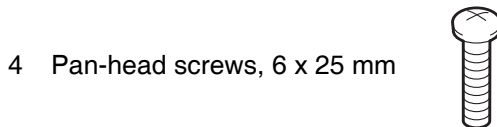
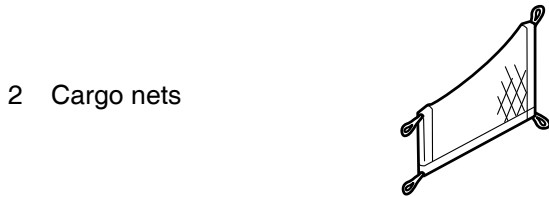
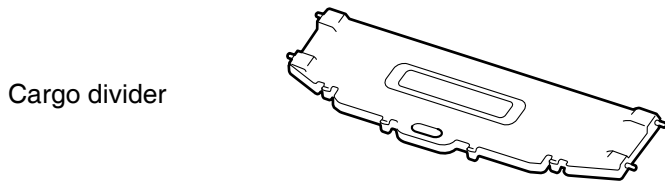

TOOLS AND SUPPLIES REQUIRED

Clip remover
Rivet nut tool (T/N: 07AAE-000A100)
Hex wrench
19 mm wrench
Drill
3 mm, 6.5 mm, and 10 mm Drill bits
Eye protection
Round file
Masking tape
Tape
Touch-up paint
Scissors
Utility knife
Screw driver
Torque wrench
Felt-tip pen

INSTALLATION

Customer Information: The information in this installation instruction is intended for use only by skilled technicians who have the proper tools, equipment, and training to correctly and safely add equipment to your vehicle. These procedures should not be attempted by "do-it-yourselfers."

1. Remove the spare tire lid (one clip).

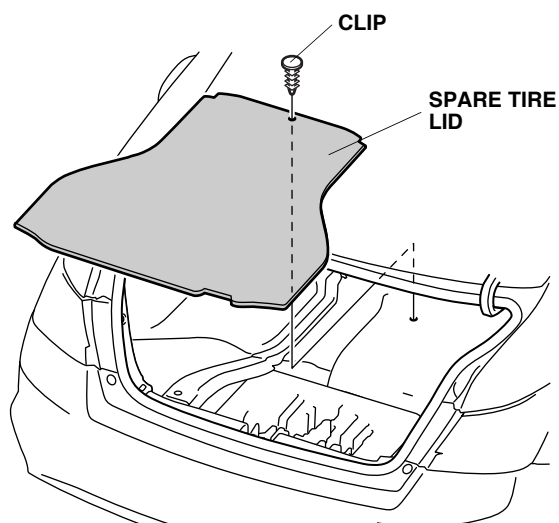

2. Remove the rear trim panel (four clips and three hooks).

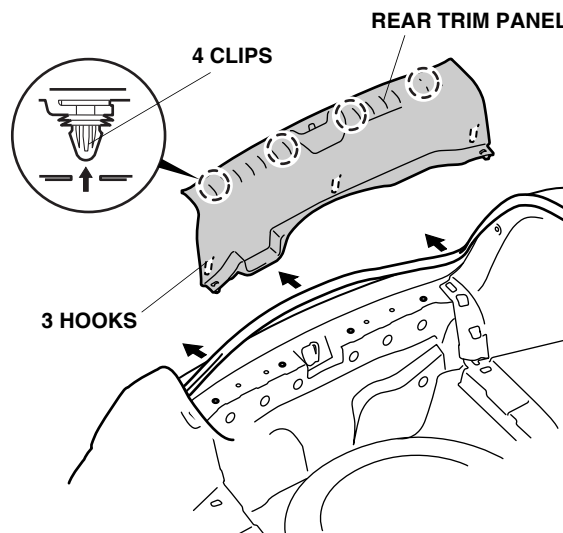

3. Remove the trunk left side trim (five clips).

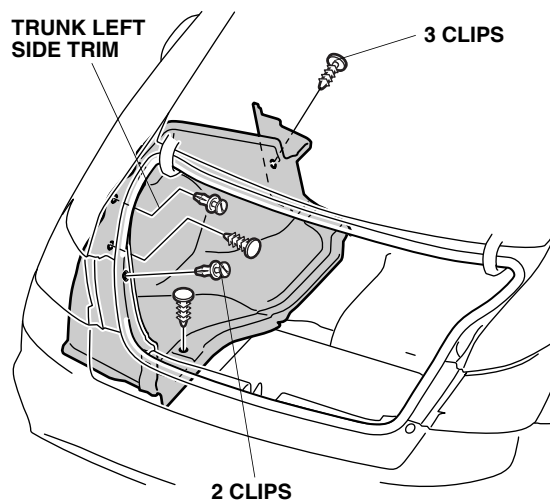

4. Remove the trunk right side trim.

Installing the Anchors and Upright Supports

- Using scissors, cut out template A as shown.

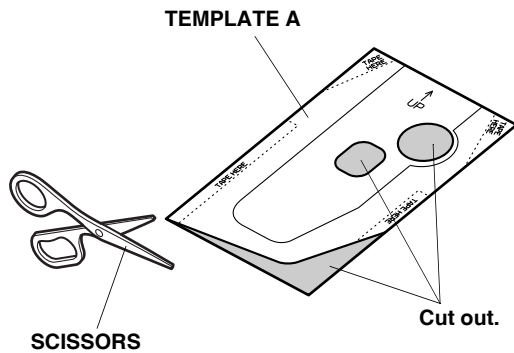

- Attach template A to the trunk left side trim using masking tape.

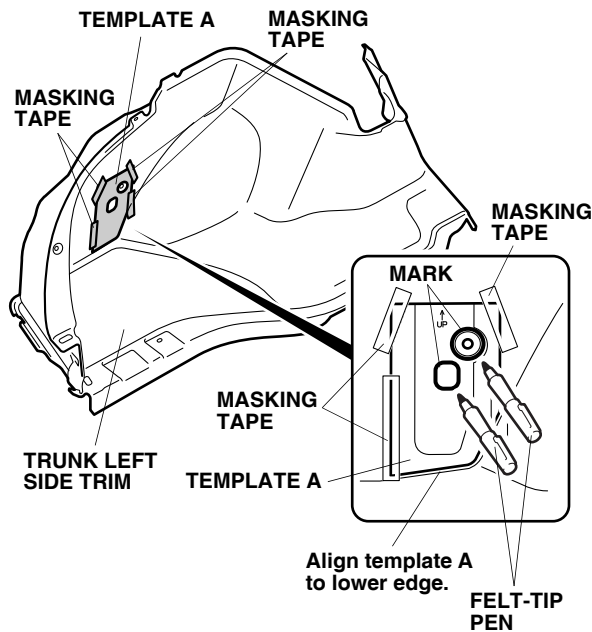

- Using a felt-tip pen, mark the trunk left side trim as indicated on the template. Remove the template.
- Using a utility knife, cut out the trunk left side trim at the marks you made.

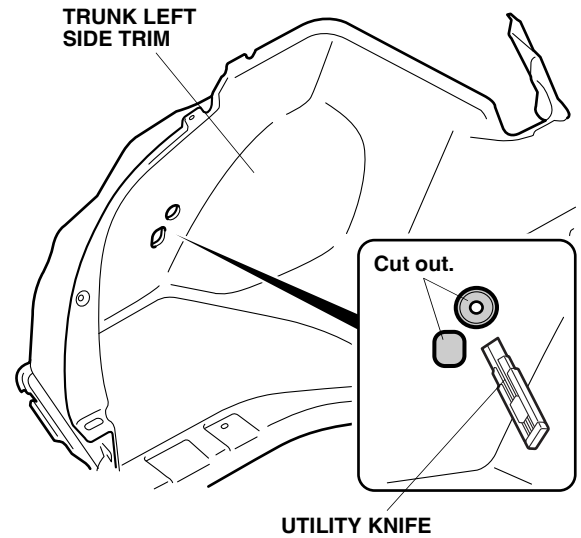

- Turn the template over and tape it to the trunk right side trim. Repeat steps 7 and 8 to mark and cut the trunk right side trim.
- Inside the trunk on the left side, attach one wire tie with clip to the trunk release cable at the measurement shown.

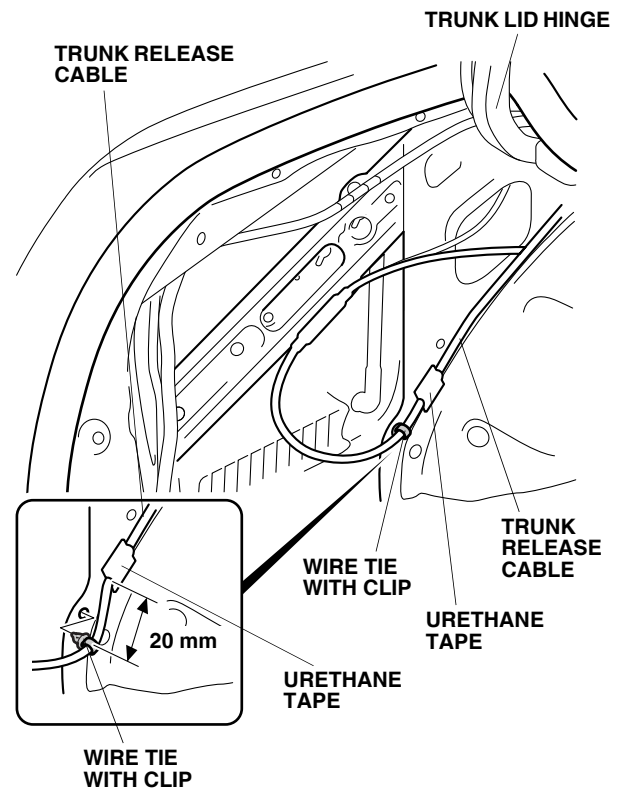

- While wearing eye protection, enlarge the two clip holes to 10 mm:

- Wrap tape around the drill bit at 20 mm from the tip of the bit.
- Remove any burrs from the edges of the holes using a round file. Apply touch-up paint to the drilled surface and allow the surface to dry thoroughly.
- Repeat the above step to drill the right side of the vehicle.

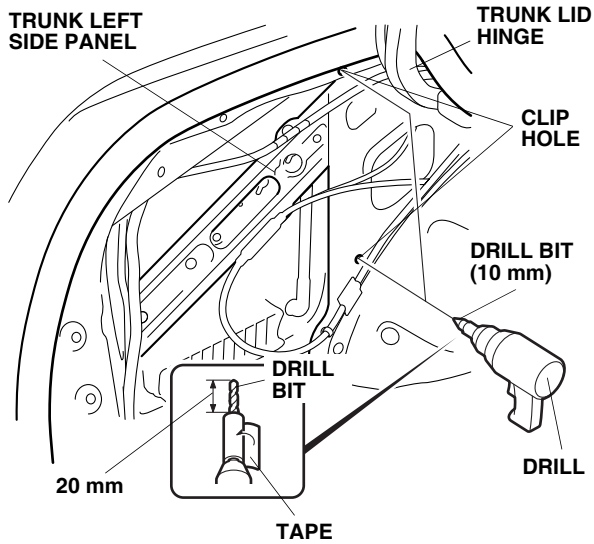

12. Install one rivet nut into each enlarged hole:

- Thread one rivet nut onto the mandrel of the rivet nut tool.

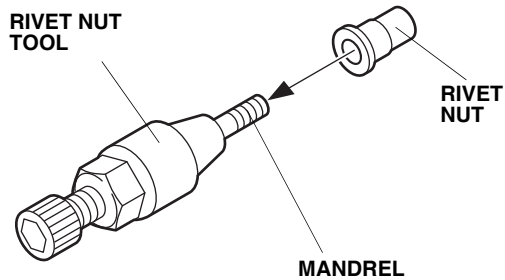

- Insert the rivet nut into the upper hole in the trunk left side panel, and install the hex wrench.

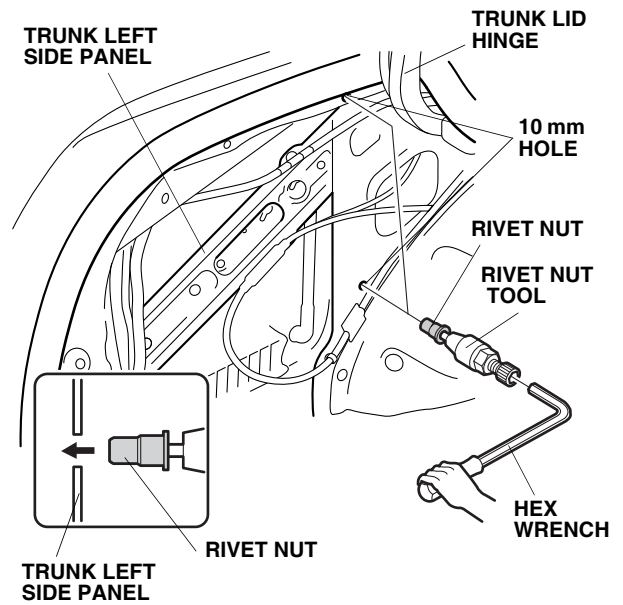

- While holding the tool with the hex wrench, use a 19 mm wrench to rotate the tool in a clockwise direction until the rivet nut is fully collapsed.

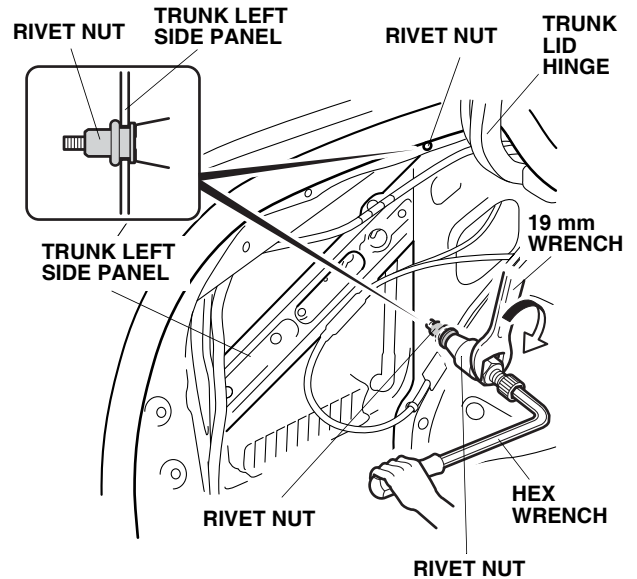

- Remove the tool from the rivet nut by turning the hex wrench counterclockwise.
- Repeat this procedure to install rivet nuts in the other three holes.
- Reinstall the trunk side trims.

- Attach template B to the back side of the rear trim panel using masking tape.

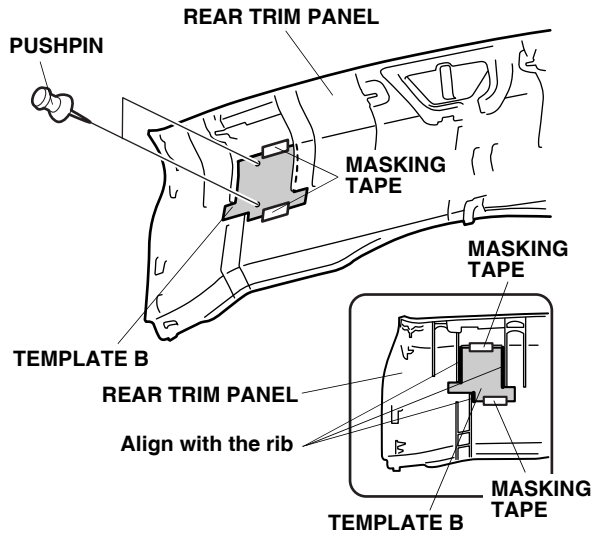

- Using a pushpin, mark the rear trim panel as indicated on the template. Remove the template.
- Turn the template over and attach it to the other side of the rear trim panel.

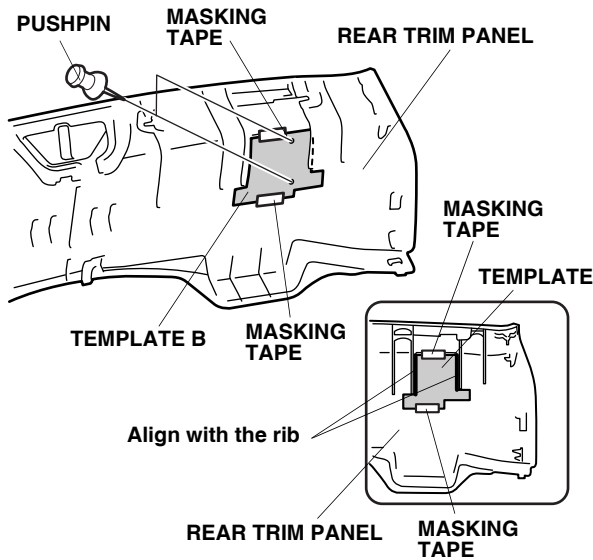

- Mark the rear trim panel the same way. Remove the template.

- While wearing eye protection, drill a 6.5 mm hole at each marked position. First drill with a 3 mm bit, and finish with a 6.5 mm drill bit. Remove any burrs from the edges of the holes.

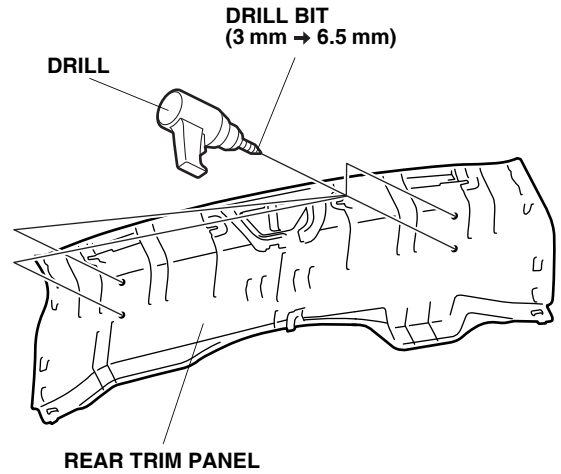

- Install the four anchors to the rear trim panel using one 6 x 16 mm flange bolt, one 6 mm lock washer, and one plain washer for each anchor. Torque the 6 x 16 mm flange bolts to 5 N·m (3.7 lb-ft). Position each anchor horizontally.

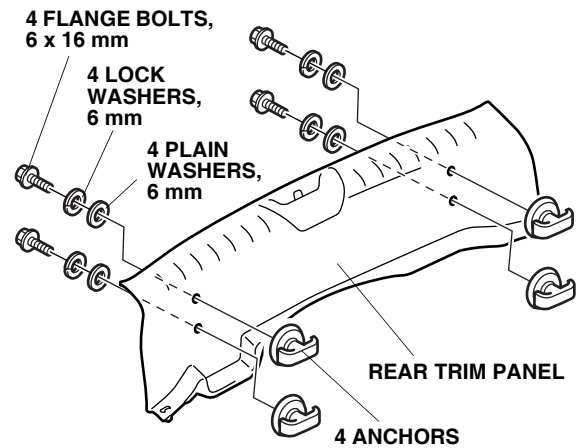

- Reinstall the rear trim panel.

20. Attach the left and right upright supports to the rivet nuts using two 6 x 25 mm pan-head screws, two 6 mm lock washers, and two collars for each. Torque the 6 x 25 mm pan-head screws to 5 N·m (3.6 lb-ft).

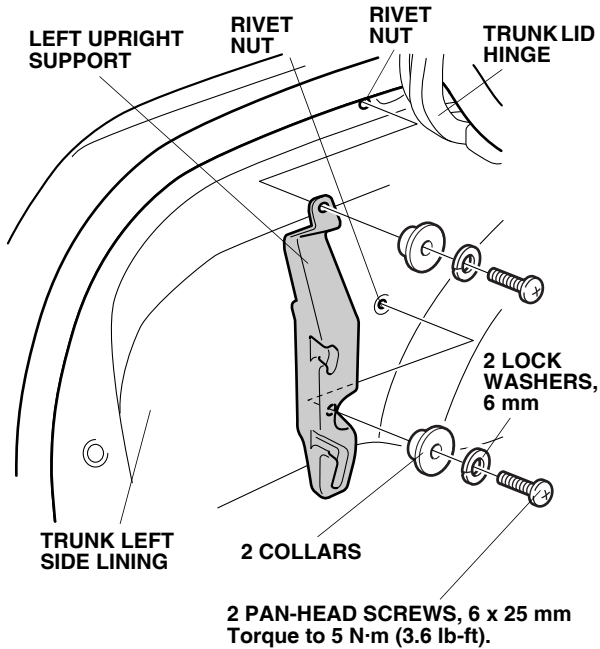

Installing the Cargo Divider/Nets

21. Attach the cargo nets onto the hooks on the cargo divider.

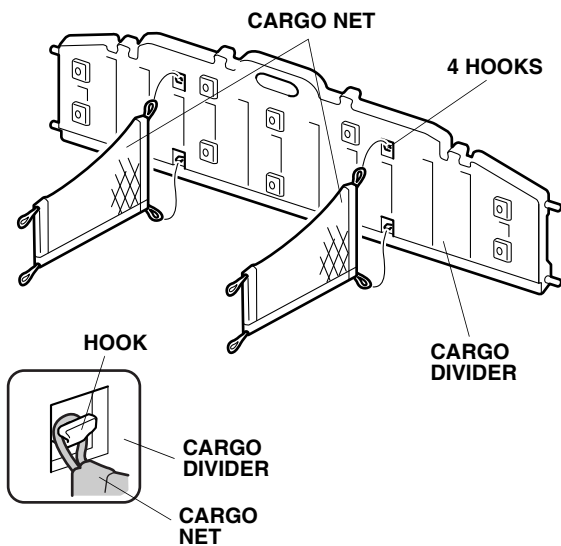

22. Slide the four pins on the cargo divider into the upright supports. Attach the cargo nets to the anchors on the rear trim panel. The cargo divider can be installed in two different positions:

Upright Position

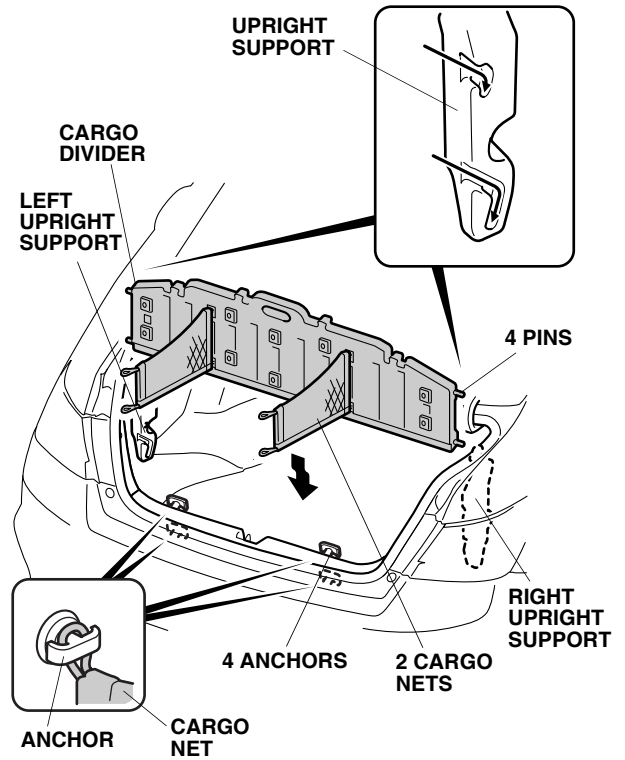

Flat Position

