



# INSTALLATION INSTRUCTIONS

Accessory

MOONROOF VISOR  
P/N 08R01-SJC-100

Application

2011 RIDGELINE

Publications No.

All 43439

Issue Date

JUNE 2010

Keep this information in the glove box for future reference.

## PARTS LIST

Moonroof visor

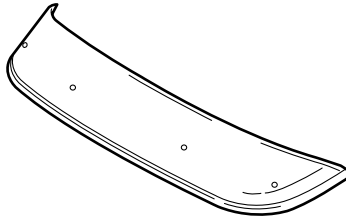

2 Front brackets A  
(long)

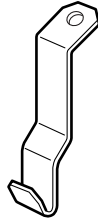

2 Side brackets B  
(short)

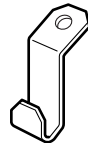

4 Screws



4 Nuts



4 Protective tapes



## TOOLS AND SUPPLIES REQUIRED

Phillips screwdriver

10 mm Combination wrench

Felt-tip pen

Tape measure

Isopropyl alcohol

Shop towel

Torque wrench

## INSTALLATION

1. Clean and wax the roof area to be covered with a high-quality paste wax.
2. Open the moonroof.
3. Using a felt-tip pen, mark the moonroof panel at the second indentation on each side of the center.

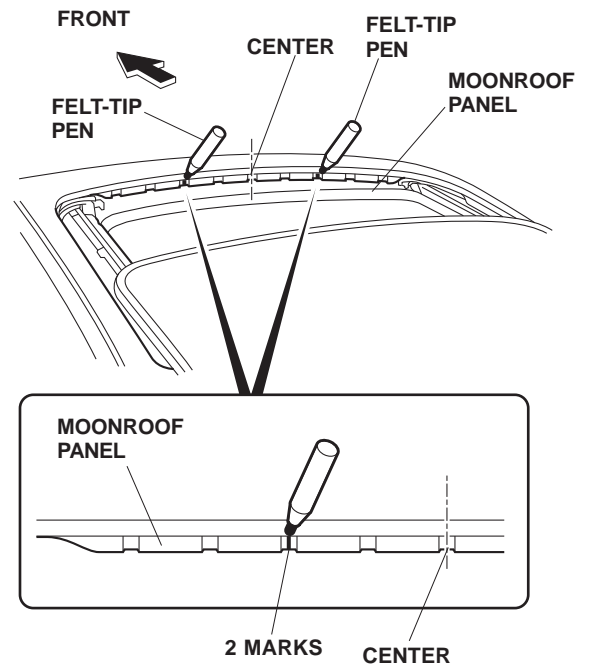

4. Locate the panel folding line on the right side of the moonroof opening. Measure 87 mm to the front of the vehicle, and make a mark on the roof. Repeat on the other side of the moonroof opening.

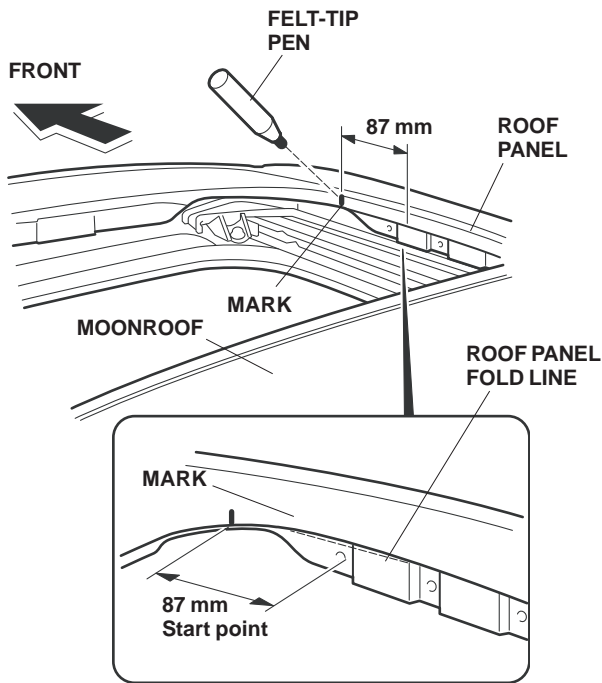

5. Using isopropyl alcohol on a shop towel, clean the roof at each of the four marks you've made but don't wipe off the marks.
6. Remove the adhesive backing from the four protective tapes, and attach one to the roof at each of the four marks you made. Wrap 6 mm of the protective tape around the lip of the moonroof opening.

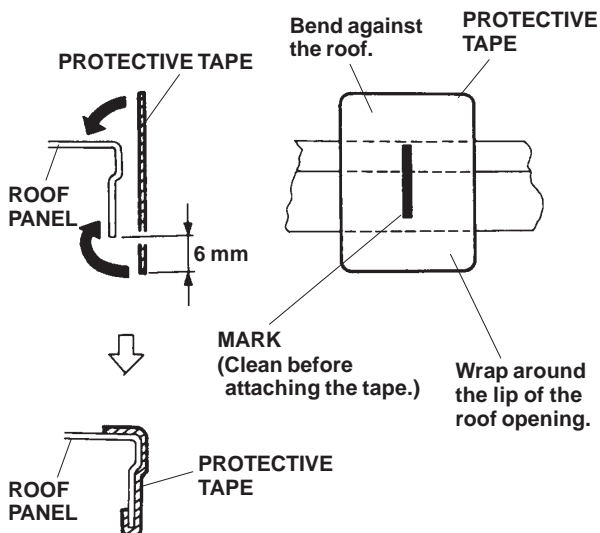

7. Place the two front brackets A into position by sliding them along the lip of the roof opening. Set the moonroof visor on the vehicle roof, in front of the moonroof opening, and adjust its position so the holes in the visor are aligned with the holes in the visor in the front brackets.

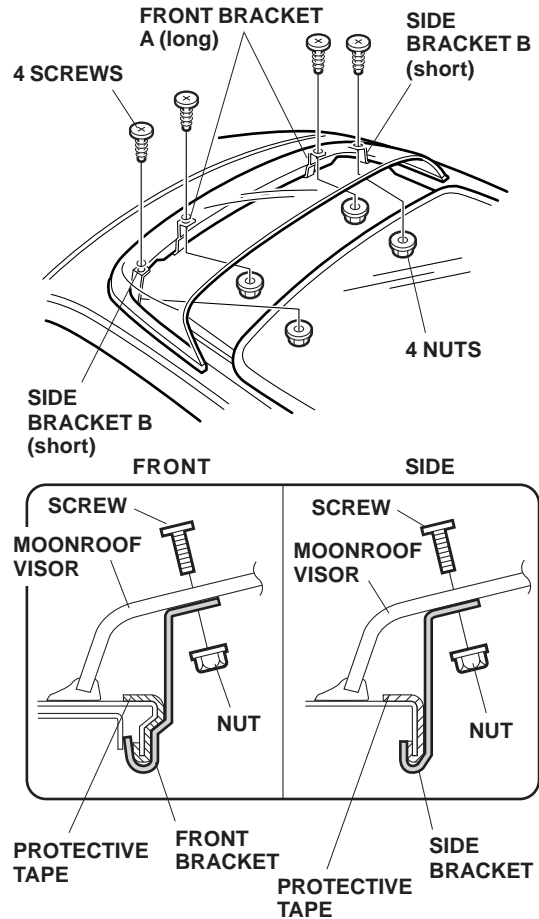

8. While holding the visor in place, install the brackets A and B with four screws and four nuts, with the end of each bracket hooked to the lip of the moonroof opening.

- Position the moonroof visor with equal spacing on all sides. Check that the rubber seal is not twisted or rolled under the visor.

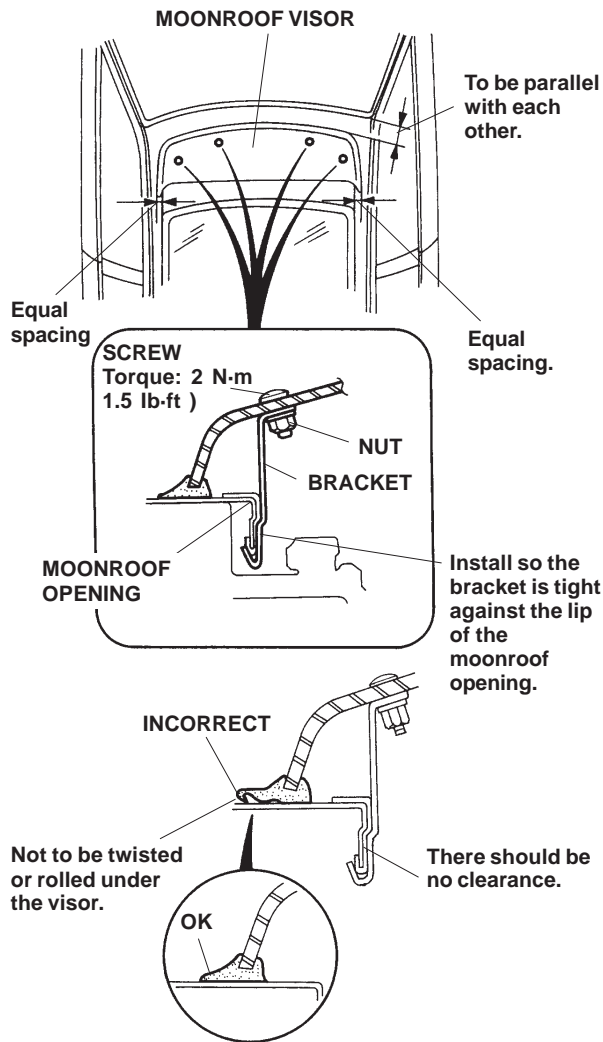

- Torque the screws to 2 N·m (1.5 lb·ft), alternating between sides. To prevent damage to the resin nuts, do not over-tighten the screws.

## CARE OF YOUR MOONROOF VISOR

- To avoid damaging the surface, never use ammonia-based cleaners or solvents to clean your moonroof visor.
- Clean with a solution of mild dishwashing soap and water using a soft cloth or chamois.
- To remove fine scratches and restore the original luster, use Meguiar's Mirror Glaze plastic cleaner and polish or an equivalent high-quality plastic cleaner.