



INSTALLATION INSTRUCTIONS

Accessory
REAR LOWER TRIM
P/N 08P46-SZA-100A

Application
2011 PILOT

Publications No.
All 43325
Issue Date
MARCH 2010

Put this information in the glove box with the vehicle owner's manual.

PARTS LIST

Rear lower trim

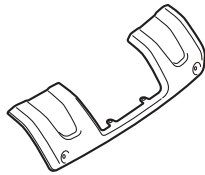

2 Rivet nuts



2 Special bolts



2 Washers



2 Spacers



4 Bolts



2 Clips

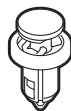

TOOLS AND SUPPLIES REQUIRED

Stubby Phillips screwdriver

Ratchet

Socket

Hex wrench

Pushpin

Drill

3 mm, 8 mm, and 10 mm Drill bits

19 mm Hole saw

Eye protection (safety goggles, face shield, ect.)

Rivet nut tool

Hex wrench

19 mm wrench

Blanket

Illustration of the Rear Lower Trim kit Installed on the Vehicle

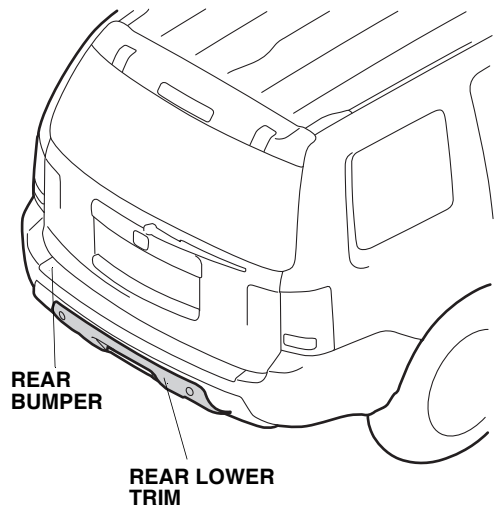

INSTALLATION

Customer Information: The information in this installation instruction is intended for use only by skilled technicians who have the proper tools, equipment, and training to correctly and safely add equipment to your vehicle. These procedures should not be attempted by “do-it-yourselfers.”

NOTE:

- Be careful not to damage the body paint finish. To prevent damage, place a blanket under the rear bumper during the installation.
1. Remove the rear bumper (two clips, two bolts, two hex bolts, and ten self-tapping screws). Have an assistant help you when removing and installing the rear bumper.

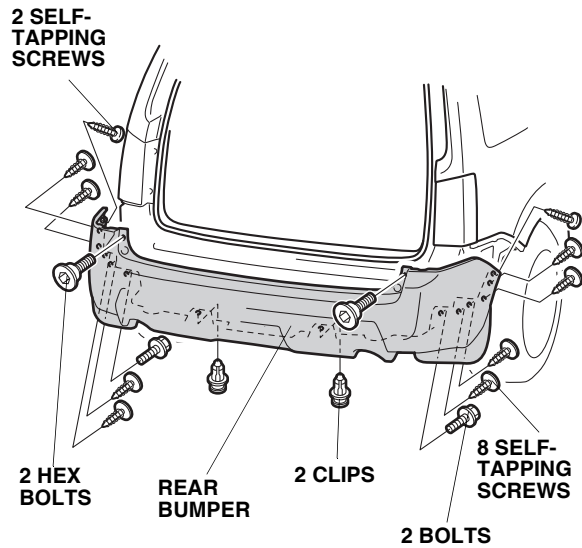

2. Remove the left and the right splash guards (four clips, four bolts, and two hooks).

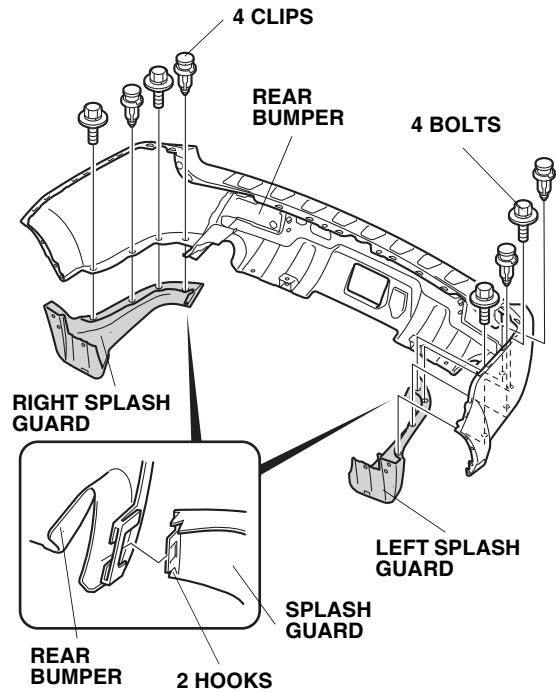

3. Remove the rear lower bumper (four self-tapping screws and twelve hooks).

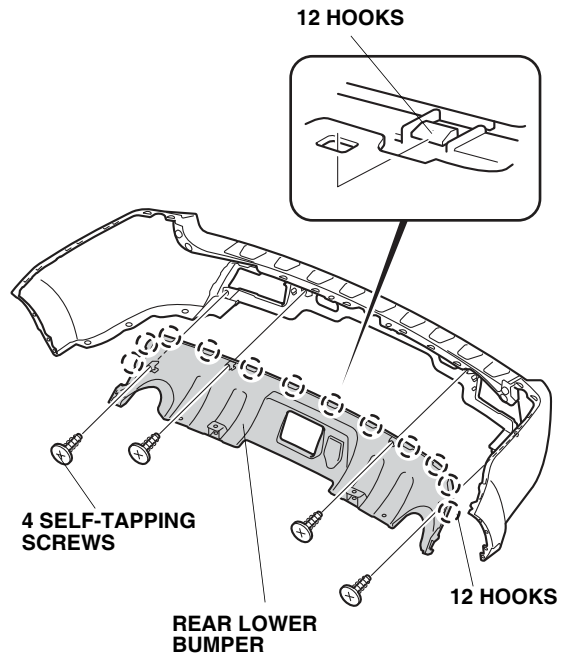

4. Inside the rear upper bumper, mark the center of the two scribe marks with a pushpin as shown.

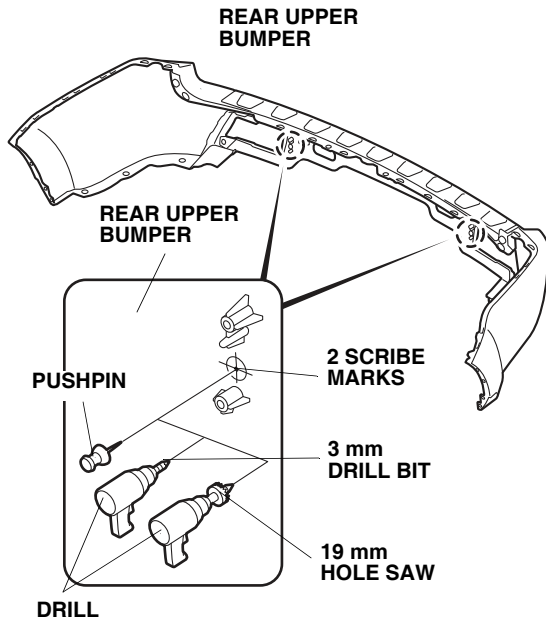

5. While wearing eye protection, drill a 3 mm hole at each of the pierced points you made in the rear upper bumper as shown.
6. Enlarge the 3 mm holes with a 19 mm hole saw, and remove all burrs.

7. Inside the rear under bumper, mark the center of the eight scribe marks with a pushpin as shown.

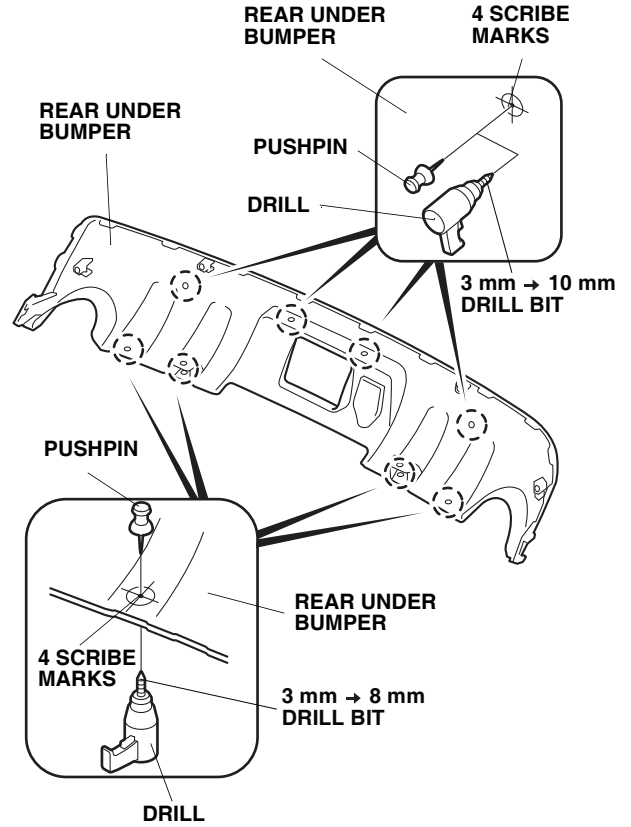

8. While wearing eye protection, drill the four upper marks. First drill with a 3 mm drill bit and finish with a 10 mm drill bit. Remove all burrs.
9. Drill the four lower marks. First drill with a 3 mm drill bit and finish with a 8 mm drill bit. Remove all burrs.

10. Install the two rivet nuts to the rear under bumper as shown.

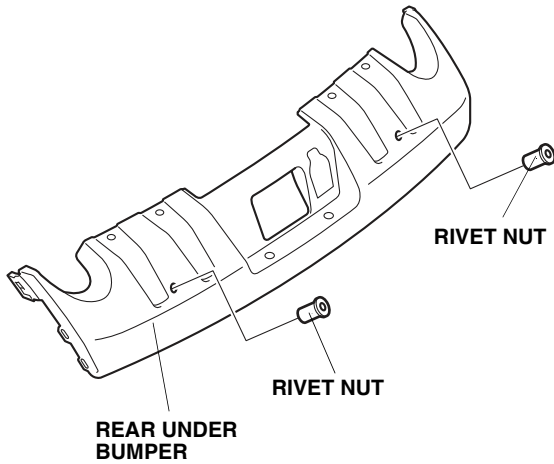

- Screw the rivet nut onto the mandrel of the rivet nut tool as shown.

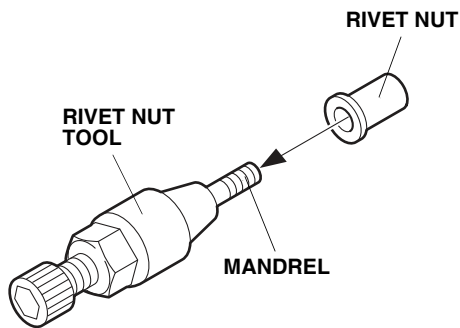

- Insert the rivet nut into the rear under bumper and install the hex wrench on the rivet nut tool.

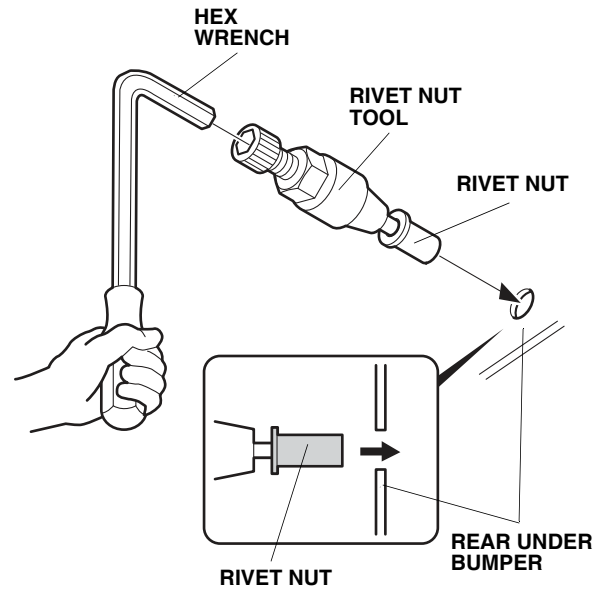

- Holding the rivet nut tool with the hex wrench, turn the 19 mm wrench clockwise and install the rivet nut in the rear under bumper.

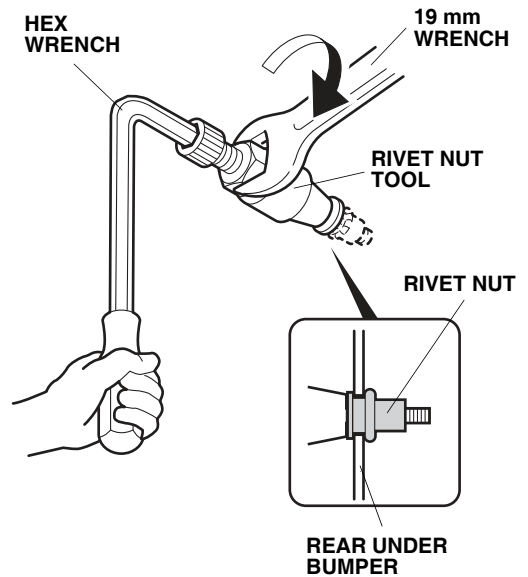

- Remove the rivet nut tool from the rivet nut by turning the hex wrench counterclockwise.

11. Position the rear lower trim to the rear under bumper, and install the two washers, two spacers, and two special bolts as shown.
Torque the special bolts to 4 N·m (0.4 kgf·m, 3 lbf·ft).

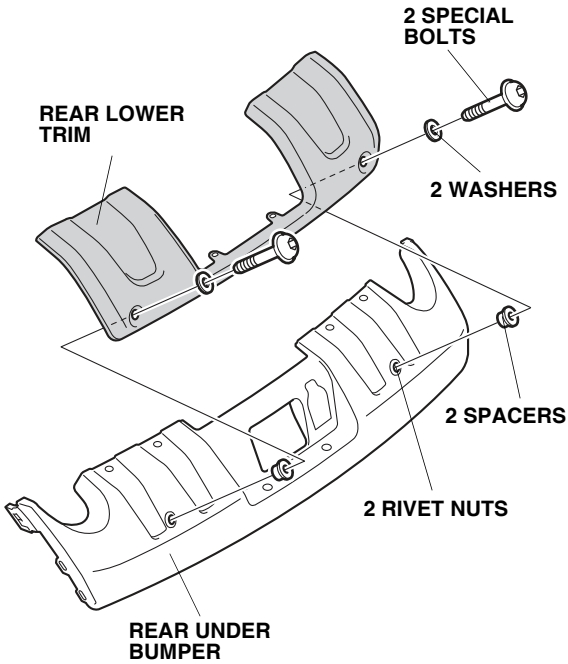

12. Secure the rear lower trim to the rear under bumper with four bolts and two clips.

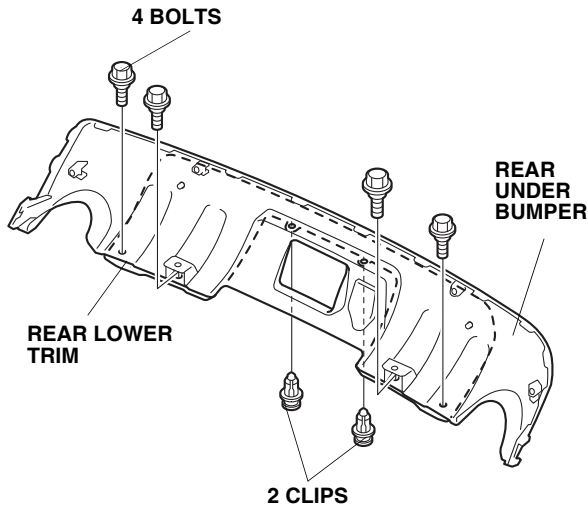

13. Reinstall the rear under bumper to the rear upper bumper.

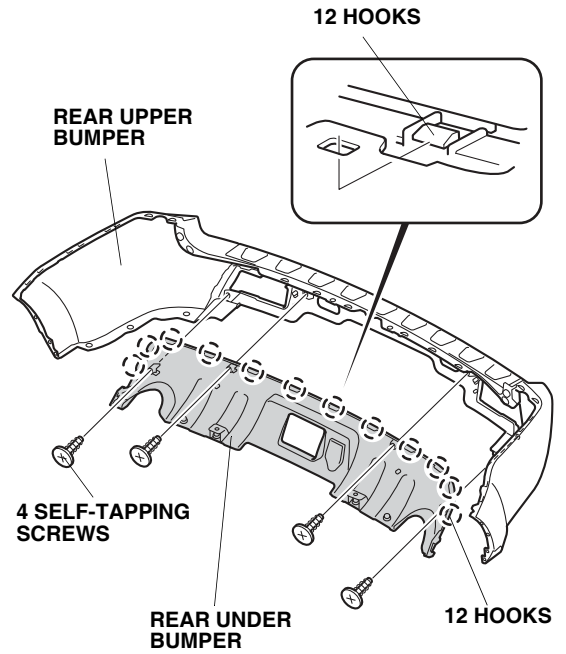

14. Reinstall the left and the right splash guards to the rear bumper.

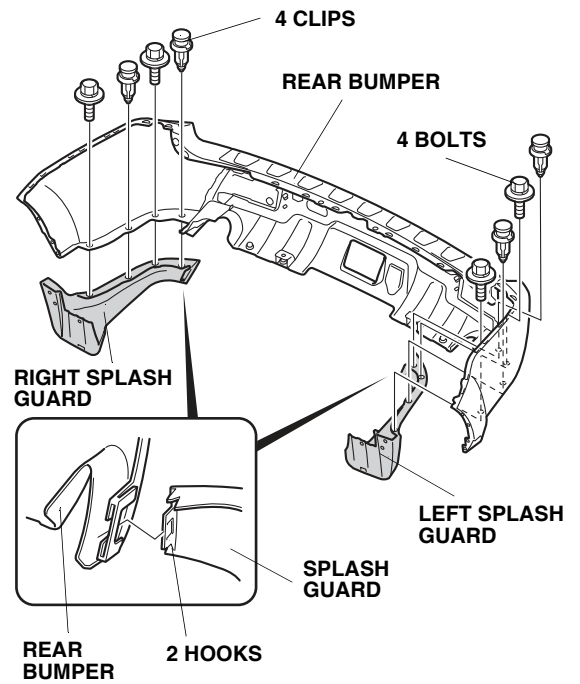

15. Reinstall the rear bumper.

