



INSTALLATION INSTRUCTIONS

Accessory
PREMIUM RUNNING BOARDS
P/N 08L33-SZA-100B

Application
2011 PILOT

Publications No.
All 43324
Issue Date
MARCH 2010

PARTS LIST

2 Premium running boards

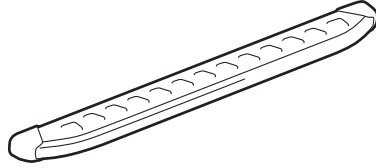

Right bracket A

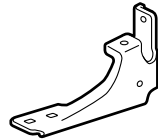

Left bracket A

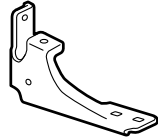

2 Right brackets B

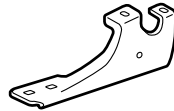

2 Left brackets B

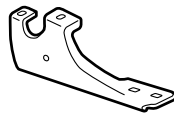

12 Flange bolts

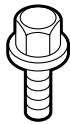

12 Flange nuts



2 Rivet nuts

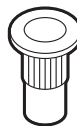

12 Square head bolts



TOOLS AND SUPPLIES REQUIRED

Torque wrench

Socket

27 mm Wrench

Hex wrench

Rivet nut tool

T/N LEML722M8

Illustration of the Premium Running Boards Installed on the Vehicle

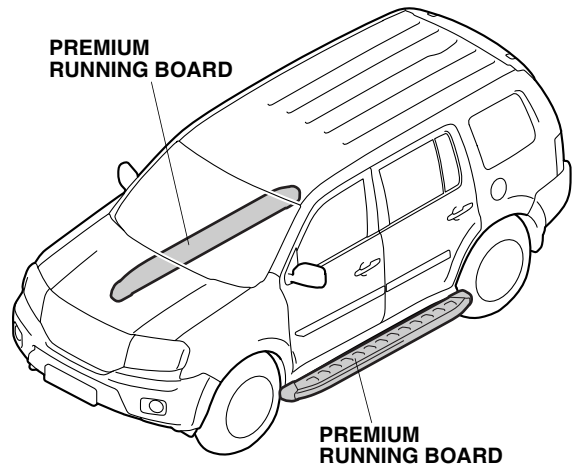

INSTALLATION

Customer Information: The information in this installation instruction is intended for use only by skilled technicians who have the proper tools, equipment, and training to correctly and safely add equipment to your vehicle. These procedures should not be attempted by “do-it-yourselfers.”

NOTE:

- Thoroughly clean the bottom of the body from the rear of the front wheels up to the front of the rear wheels.
- Be careful not to damage the body paint finish. To prevent damage, place a blanket under the premium running board during the installation.
- These instructions show the left premium running board being installed; the same procedure applies to installing the right premium running board.

1. Install the rivet nut to the vehicle frame as shown.

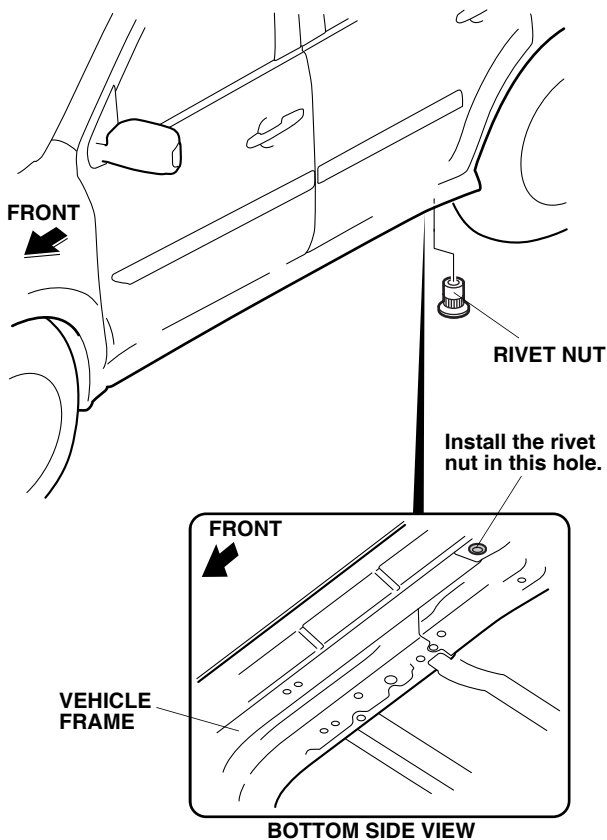

- Screw the rivet nut onto the mandrel of the rivet nut tool as shown.

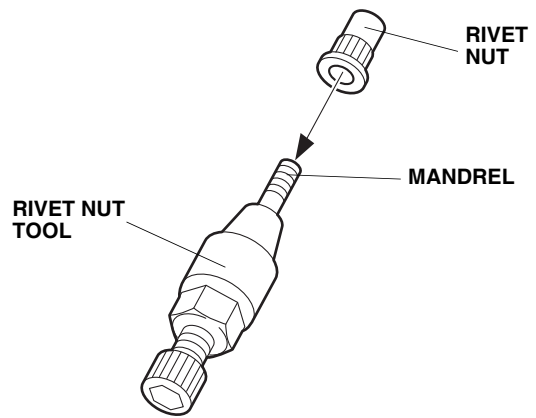

- Insert the rivet nut into the hole in the vehicle frame and install the hex wrench on the rivet nut tool.

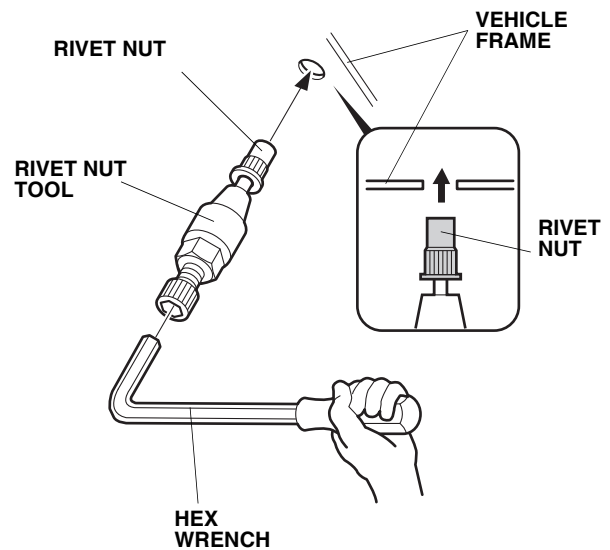

- Holding the rivet nut tool with the hex wrench, turn the 27 mm wrench clockwise and install the rivet nut in the vehicle frame.

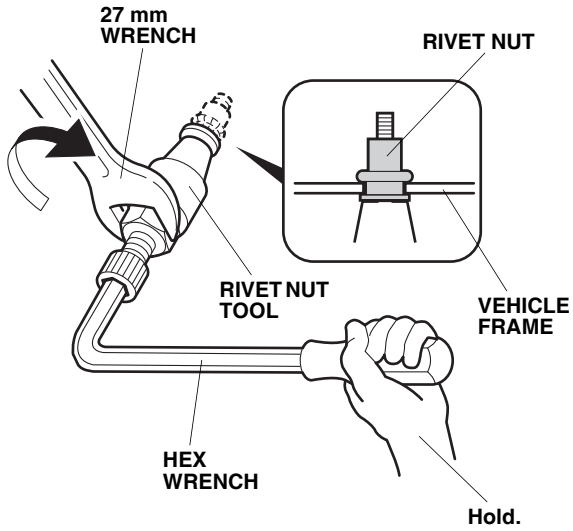

- Remove the rivet nut tool from the rivet nut by turning the hex wrench counterclockwise.

2. Install left bracket A on the vehicle frame with two flange bolts. Do not tighten the flange bolts yet. Make sure the flange bolts are installed in the correct locations.

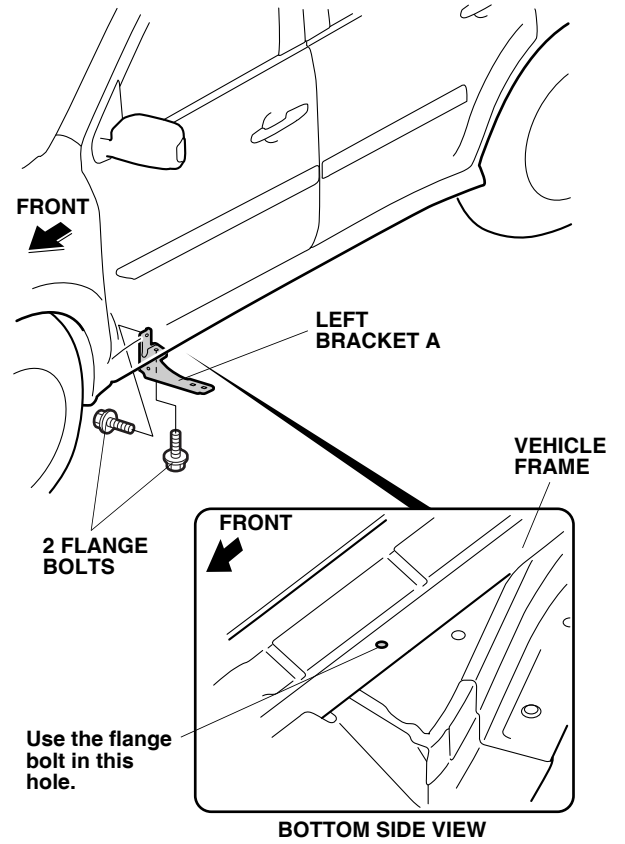

3. Install the two left brackets B on the vehicle frame using two flange bolts for each. Do not tighten the flange bolts yet. Make sure the flange bolts are installed in the correct locations.

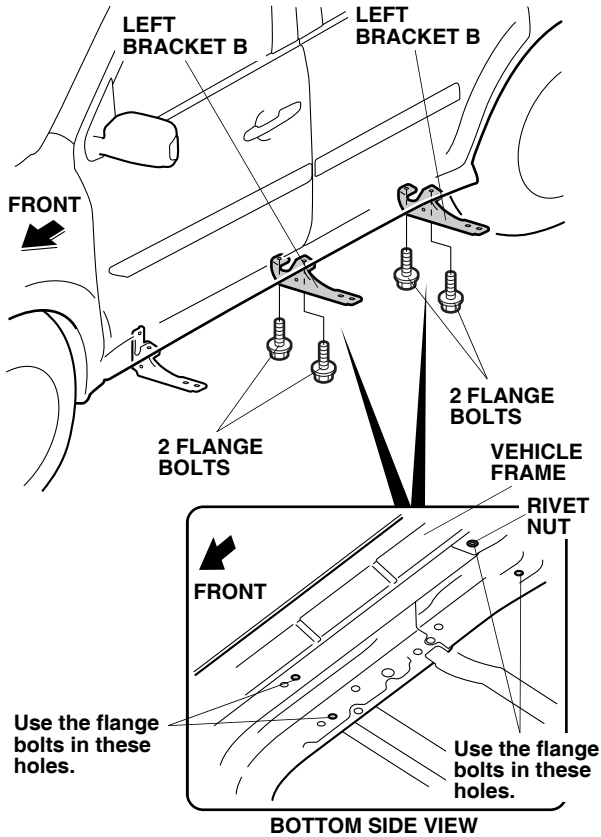

4. Slide three square head bolts into each groove on the premium running board.

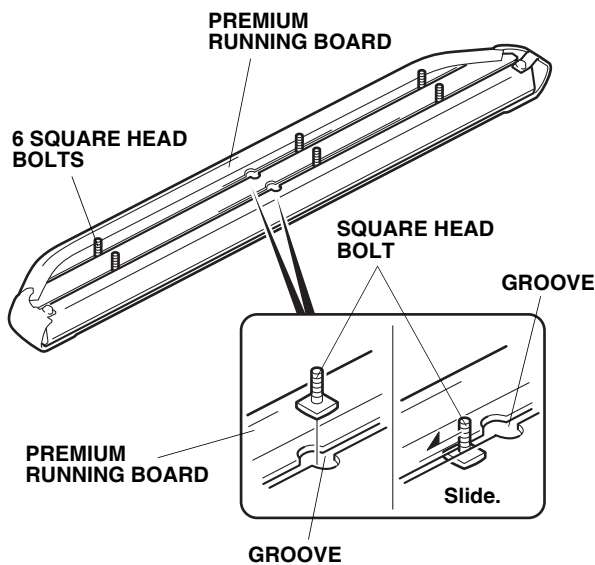

5. Position the premium running board on the left bracket A and the two left brackets B. Install the premium running board with six flange nuts. Do not tighten the flange nuts yet.

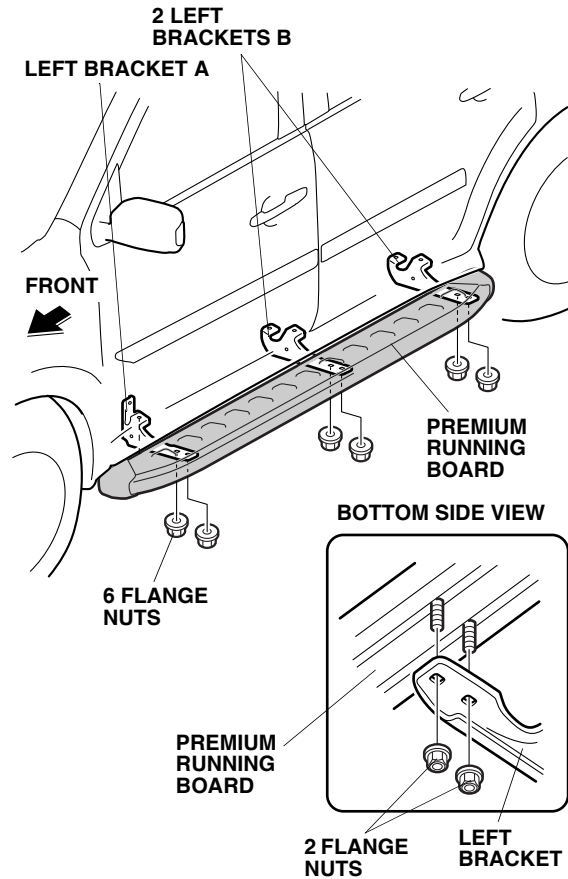

- Align the center of the premium running board as shown.

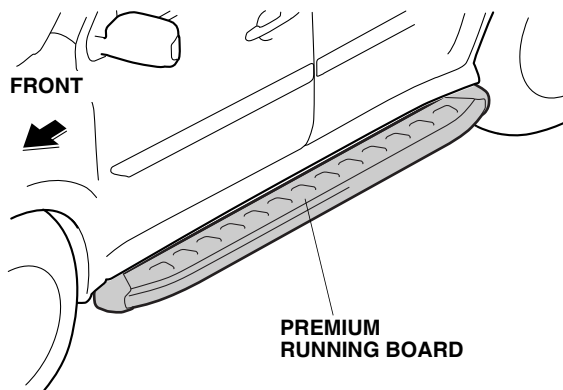
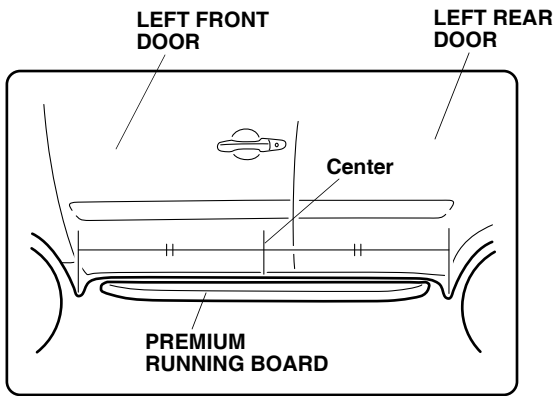

- Tighten the six flange nuts that were loosely installed in step 5. Torque the flange nuts to 27 N·m (19 lbf·ft).
- Tighten the six flange bolts that were loosely installed in step 2 and step 3. Torque the flange bolts to 27 N·m (19 lbf·ft).
- Repeat steps 1 through 8 to install the premium running board on the right side of the vehicle.