



# INSTALLATION INSTRUCTIONS

Accessory  
**FOG LIGHTS**  
P/N 08V31-TK6-100

Application  
**2011 FIT**  
**(BASE MODEL)**

Publications No.  
**All 45092**  
Issue Date  
**NOV 2010**

## PARTS LIST

Right fog light

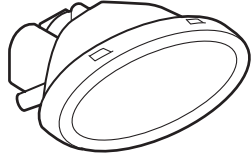

Left fog light

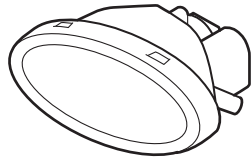

Switch harness



Fog light harness

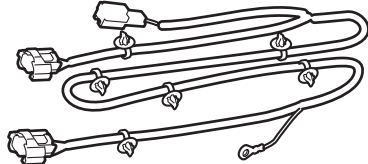

Bracket assembly (R)

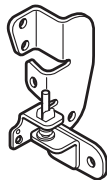

Bracket assembly (L)

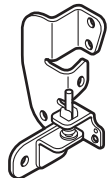

Bracket (R)



Bracket (L)

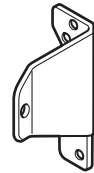

Relay bracket



Right cover

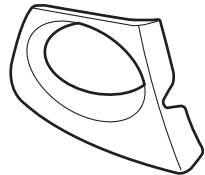

Left cover

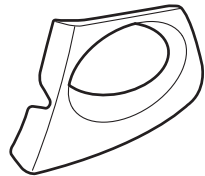

Fog light switch

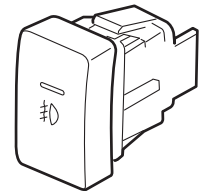

Wire tie with clip

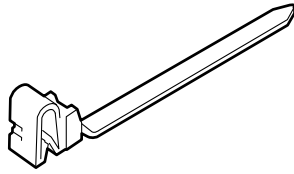

Relay

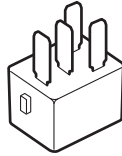

20A fuse

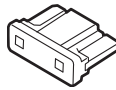

Fuse label

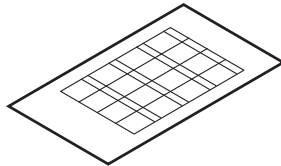

4 Step-screws



2 Washer-screws



16 Self-tapping screws



11 Wire ties

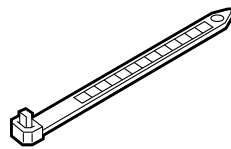

## TOOLS AND SUPPLIES REQUIRED

10 mm Wrench

Diagonal cutters

KTC trim tool set (KTC ATP2014J)

Eye protection (face shield, safety goggles, etc.)

Drill

3 mm Drill bit

Hacksaw

Isopropyl alcohol

Shop towel

Flat-tip screwdriver

Phillips screwdriver

Ratchet

File

10 mm Socket

Cardboard or blanket

20 mm and 25 mm Hole saws

Pushpin

Duct tape

### *Illustration of the Fog Lights Installed on the Vehicle*

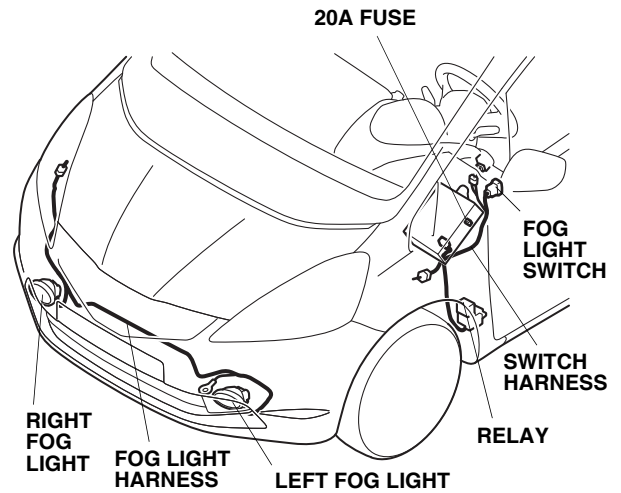

## INSTALLATION

**Customer Information:** The information in this installation instruction is intended for use only by skilled technicians who have the proper tools, equipment, and training to correctly and safely add equipment to your vehicle. These procedures should not be attempted by “do-it-yourselfers.”

1. Make sure you have the anti-theft code for the audio unit and navigation system (if equipped), then write down the audio unit presets.
2. Disconnect the negative cable from the battery.
3. Remove the front bumper:
  - Remove the front grille cover (eight clips).

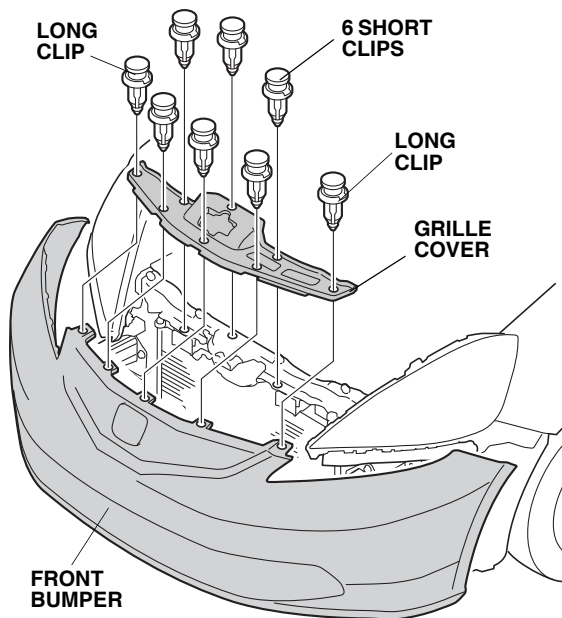

- Remove the five clips and the six self-tapping screws from the bumper.

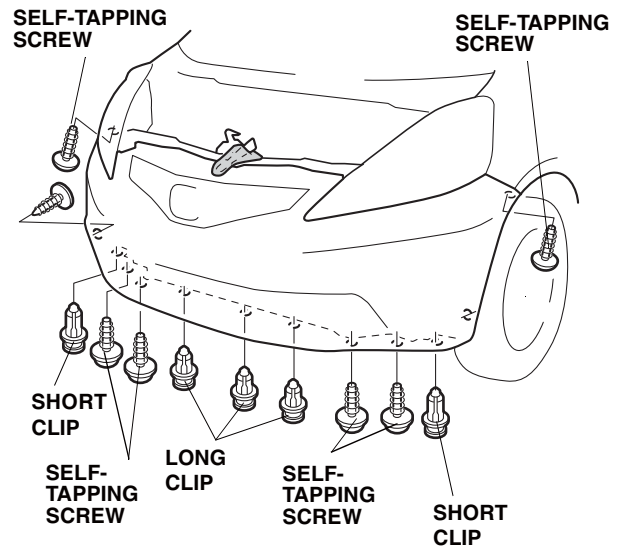

- Attach duct tape to the bumper in the area shown.

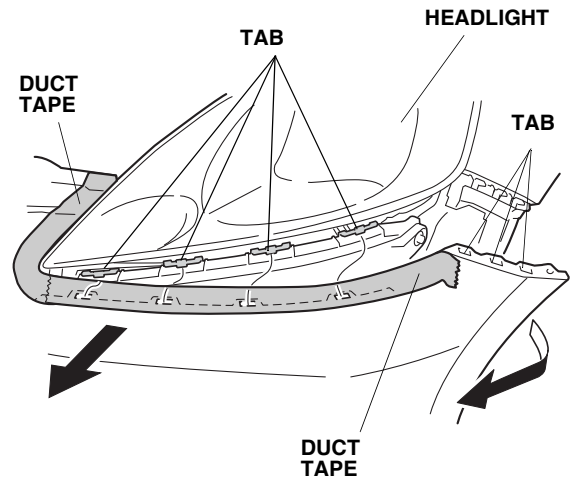

- With the help of an assistant, release the three tabs between the fender and the bumper on each side, and pull the bumper straight out to release the four tabs along the bottom of the headlight.

**NOTE:** If you try to remove the bumper without an assistant, you may scratch the bumper around the headlight area.

- Place the front bumper on a blanket to prevent damage.

## Installing the Fog Lights

- On the inside of the front bumper, locate the seven preset marks. Using a pushpin, pierce the center of each preset mark.

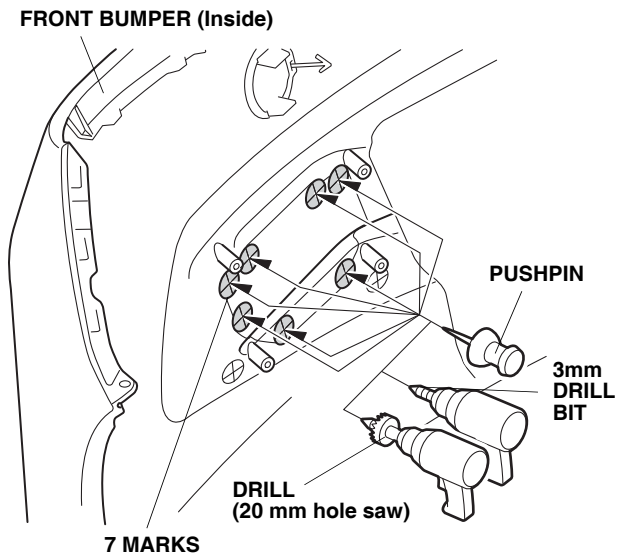

- While wearing eye protection, drill each of the seven pierced marks. First drill with a 3 mm drill bit, then enlarge the holes using a 20 mm hole saw.
- Using a hacksaw, cut out the front bumper between the 20 mm holes.

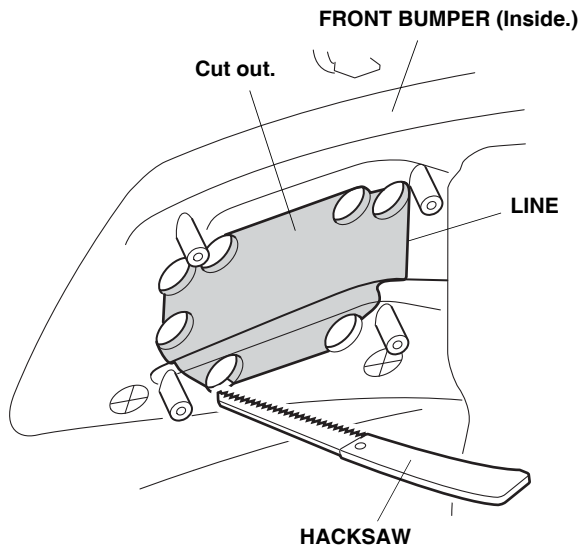

- Remove any burrs from the edges of the cutout.

- Locate the two remaining preset marks below the cutout. Using a pushpin, pierce the center of the two preset marks.

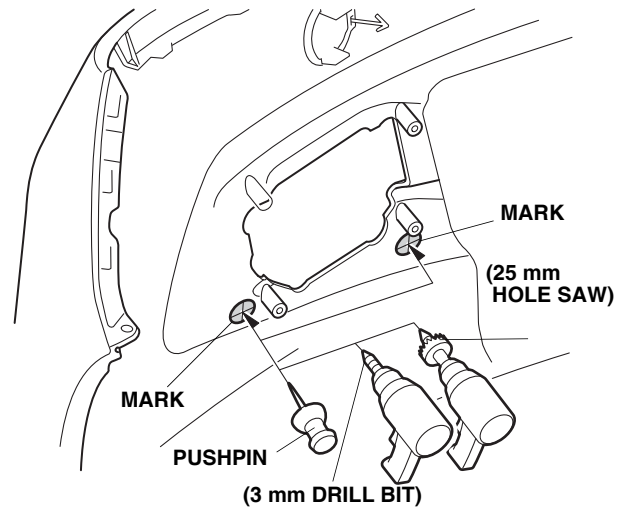

- While wearing eye protection, drill the two pierced marks. First drill with a 3 mm drill bit, then enlarge the hole using a 25 mm hole saw.  
NOTE: The drilled holes will be larger than the preset marks.
- Locate the preset mark along the bottom of the front bumper. Using a pushpin, pierce the center of the preset mark.

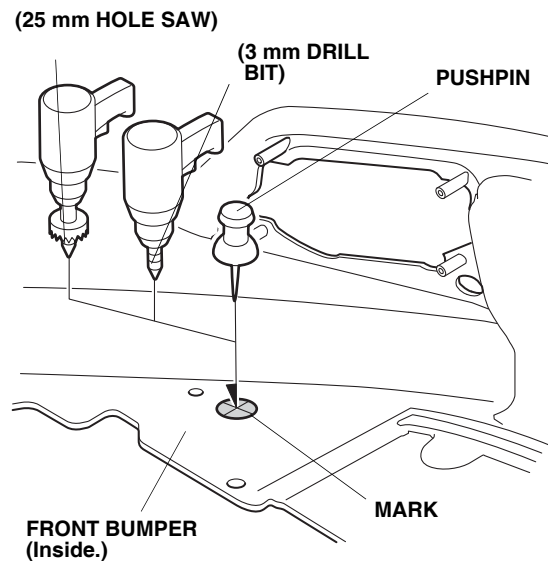

- While wearing eye protection, drill the pierced mark. First drill with a 3 mm drill bit, then enlarge the hole using a 25 mm hole saw.
- Remove any burrs from the drilled holes.
- Repeat steps 4 thru 12 to drill and cut the bumper on the right side.

14. Using one washer-screw and one step-screw, install the bracket assembly (L) to the left fog light.

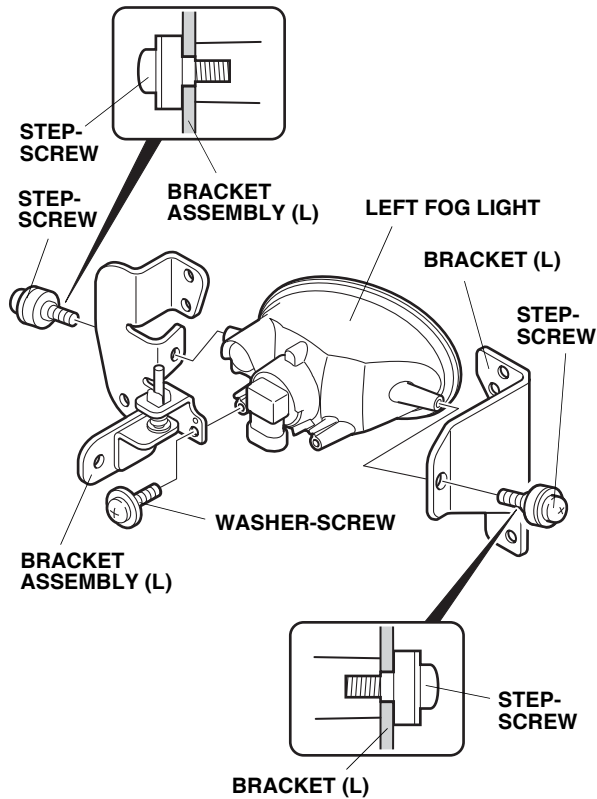

15. Using one step-screw, install the bracket (L) to the left fog light.
16. Using four self-tapping screws, secure the left fog light assembly to the front bumper.

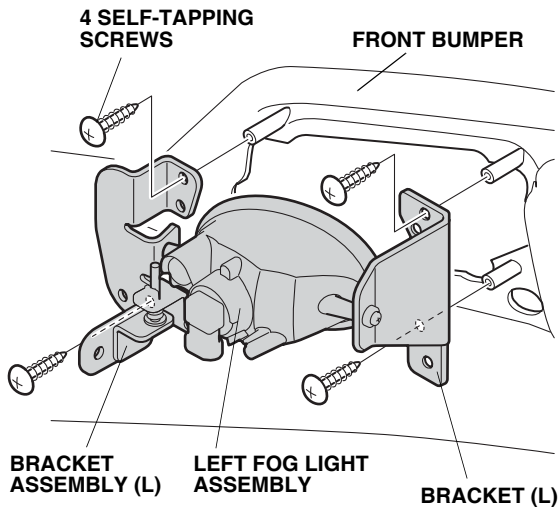

17. Install the left cover over the left fog light.

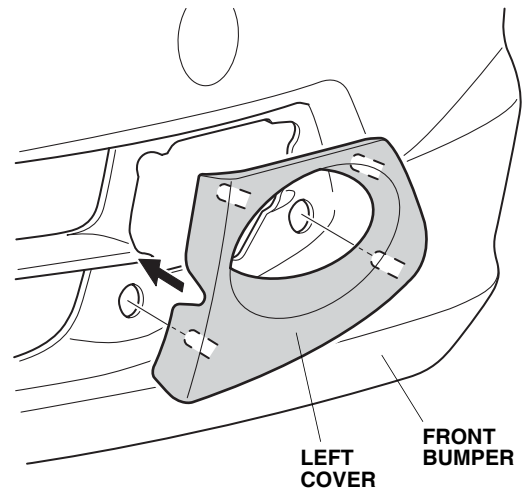

18. Using four self-tapping screws, secure the left fog light cover to the fog light bracket.

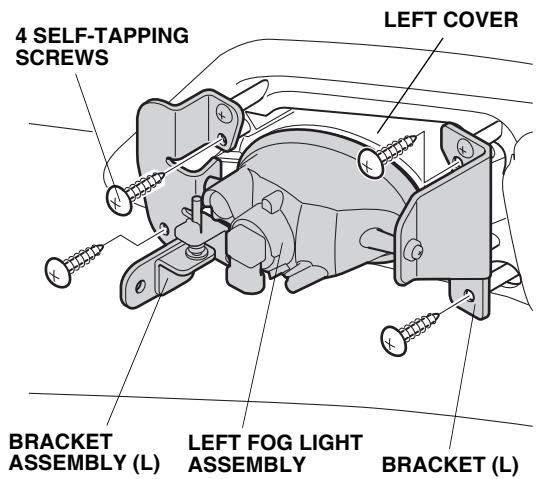

19. Repeat steps 14 thru 18 to install the right fog light and cover.

## Routing the Fog Light Harness

20. Turn the steering wheel all the way counterclockwise.
21. At the right front wheel, remove the two clips and pull the right front inner fender out to locate the vehicle 1-pin connector.

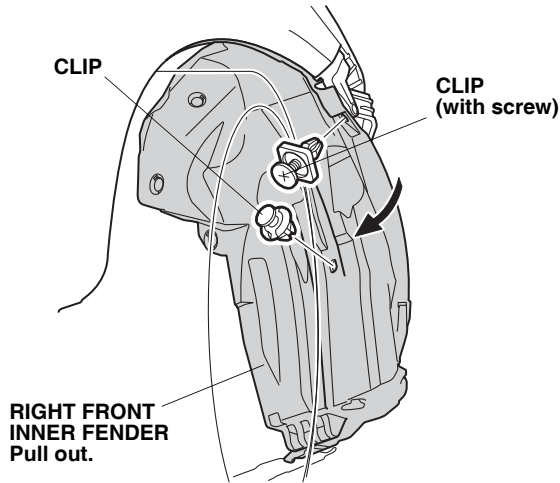

22. Remove the blue tape to free the vehicle 1-pin connector from the vehicle harness.

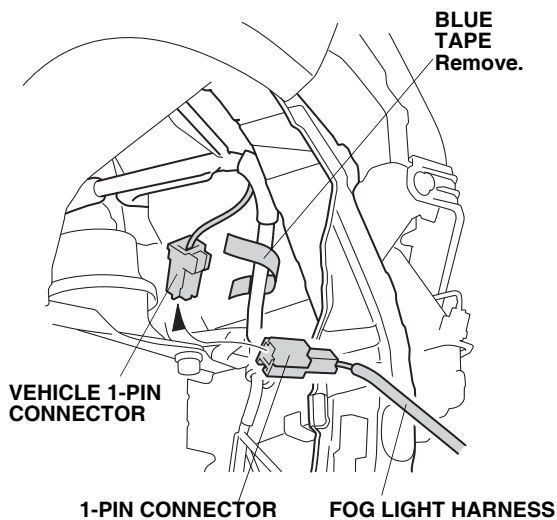

23. Plug the fog light harness 1-pin connector into the vehicle 1-pin connector.

24. Route the fog light harness downward. Secure the 1-pin connector to the vehicle harness using one wire tie.

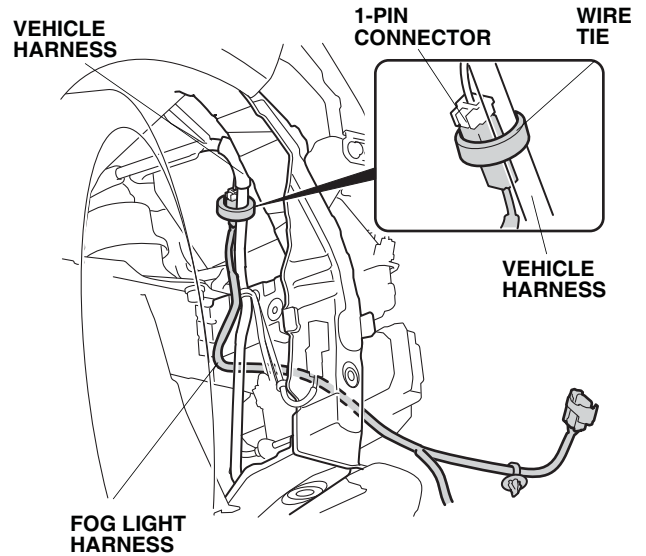

25. Along the vehicle harness, secure the fog light harness with two wire ties.

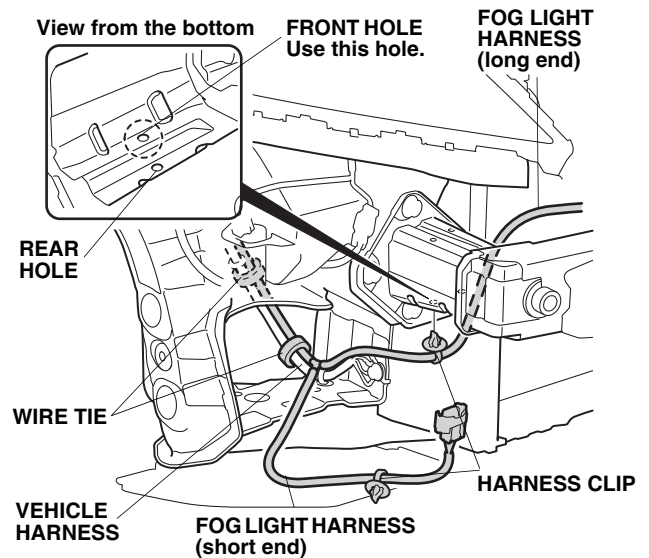

26. Route the long end of the fog light harness under the bumper beam, and insert the harness clip into the front hole in the bumper beam.

27. Route the long end of the fog light harness across the front of the vehicle, and insert the two harness clips into the front bumper beam.

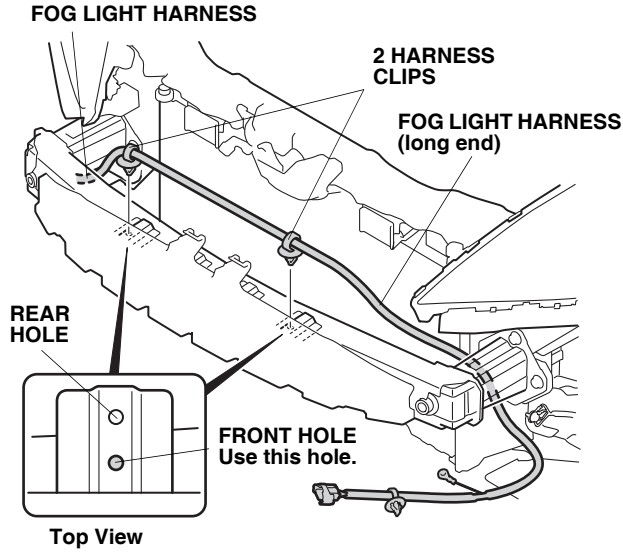

28. Route the fog light harness under the left bumper beam, and insert the harness clip into the hole in the bumper beam.

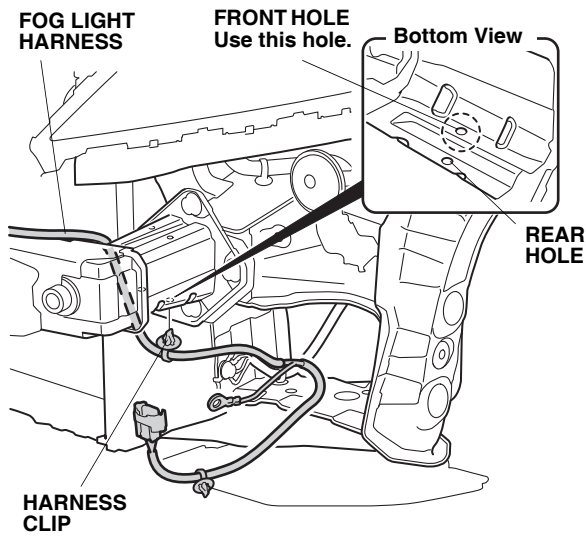

29. Remove the vehicle ground bolt. Attach the fog light harness ground to the vehicle ground and reinstall the vehicle ground bolt.

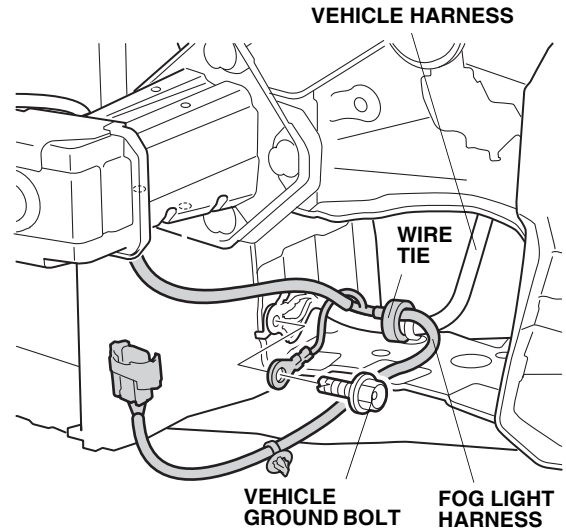

30. Secure the fog light harness to the vehicle harness with one wire tie.



31. With the help of an assistant, move the front bumper close to the vehicle. On each side, plug the fog light harness 2-pin connector into the fog light, and insert the harness clip into the hole in the fog light bracket assembly. Reinstall the front bumper.

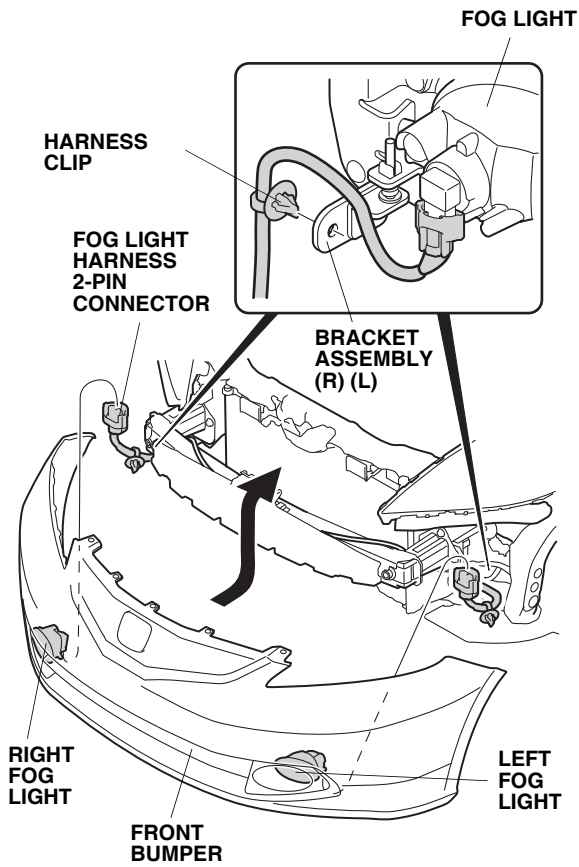

32. Reinstall the inner fender.

### Routing the Switch Harness

33. Under the dash on the left side of the vehicle, turn the knob of the driver's dashboard under cover counterclockwise. Remove the driver's dashboard under cover (one clip and two tabs).

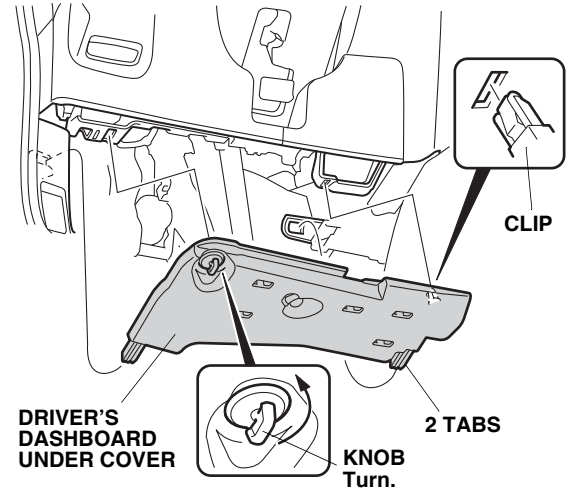

34. Pull away the door seal from the driver's kick panel, then remove the driver's kick panel (two clips and two tabs).

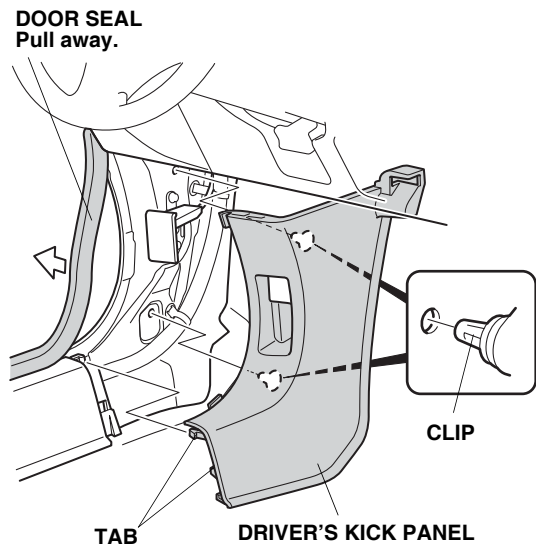



35. Remove the fuse access panel (five tabs, two clips, and two holders). If equipped, remove the ambient light harness connector and the wire tie with clip.

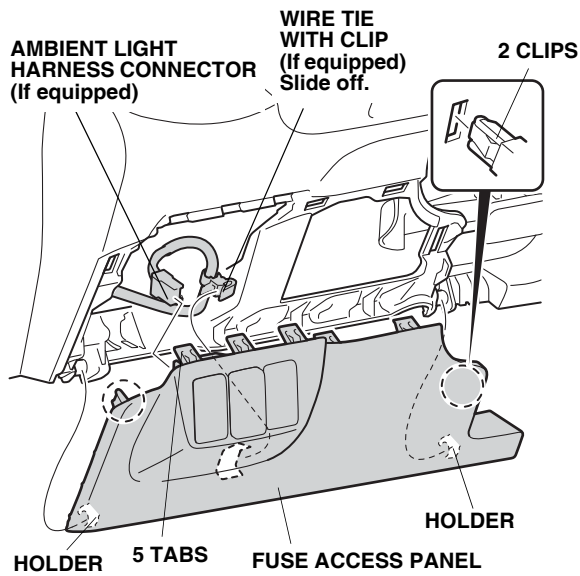

36. Locate the vehicle 2-pin connector blue-taped to the vehicle harness. Remove the blue tape to free the vehicle 2-pin connector.

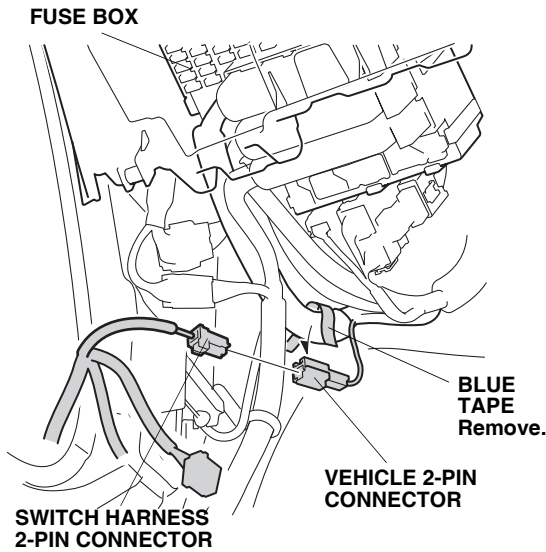

37. Plug the switch harness 2-pin connector to the vehicle 2-pin connector.

38. Remove the lower bolt from the hood release lever bracket.

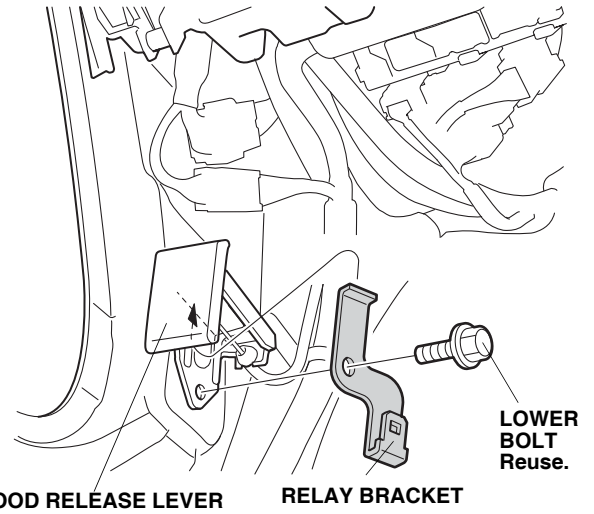

39. Attach the relay bracket to the hood release lever bracket, and reinstall the lower bolt.  
40. Install the relay into the switch harness relay block, and slide the relay block onto the switch harness relay bracket.

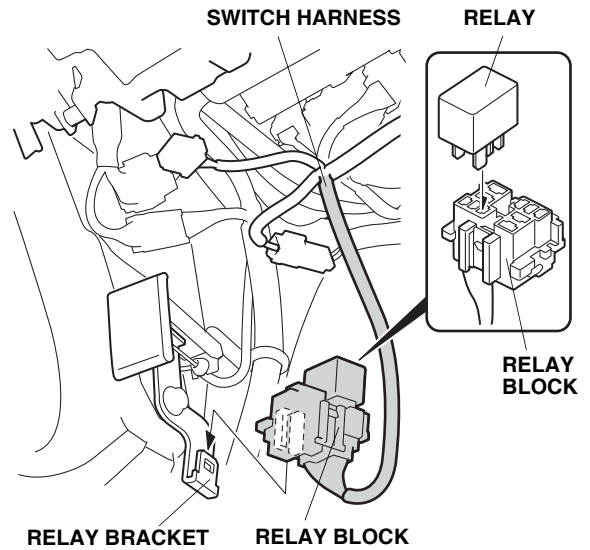

41. Using isopropyl alcohol on a shop towel, clean the No. 4 area on the driver's kick panel, then attach the fuse label (20A option fuse, diagonal line) to the cleaned area.

NOTE: If a security system is installed, the fuse label is already attached to the No. 4 area. You do not need to attach the label from the kit.

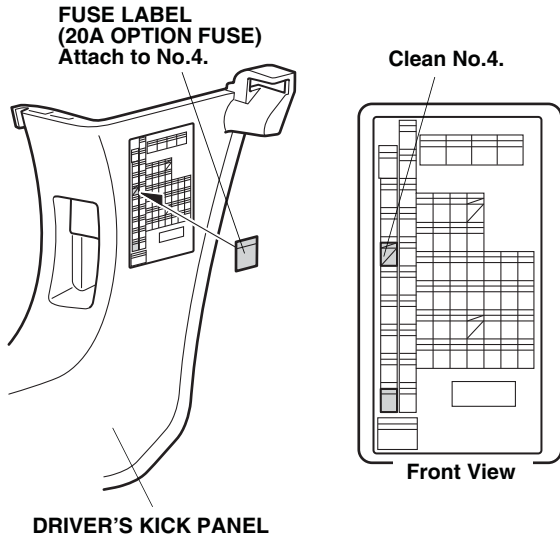

42. Insert the 20A fuse into the No. 4 position (the sixth position from the bottom) of the fuse box.

NOTE: If a security system is installed, a 20A fuse is already installed in the fuse box. There is no need to install the fog light 20A fuse from the kit.

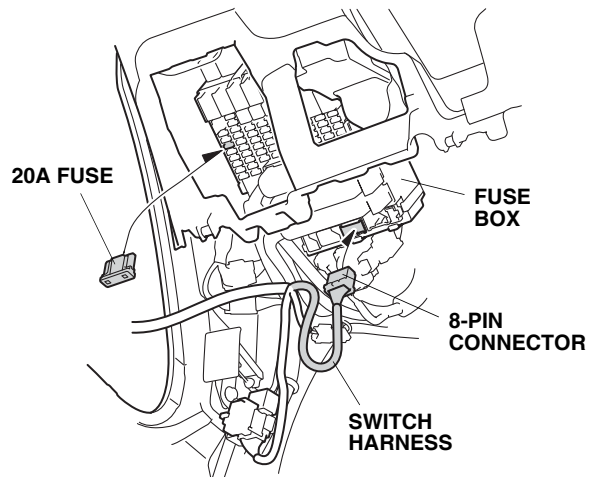
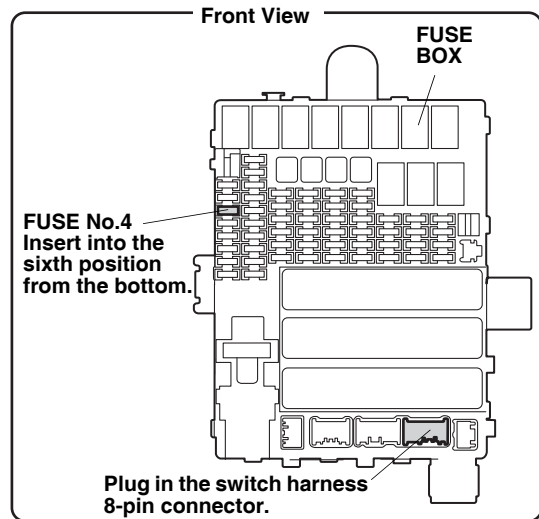

43. Plug the switch harness 8-pin connector into the slot shown above.

NOTE: If the vehicle is equipped with a security system, remove the dummy connector from the security system harness, and plug the fog light harness into the security system harness.

44. Route the switch harness 5-pin connector out through the dashboard opening.

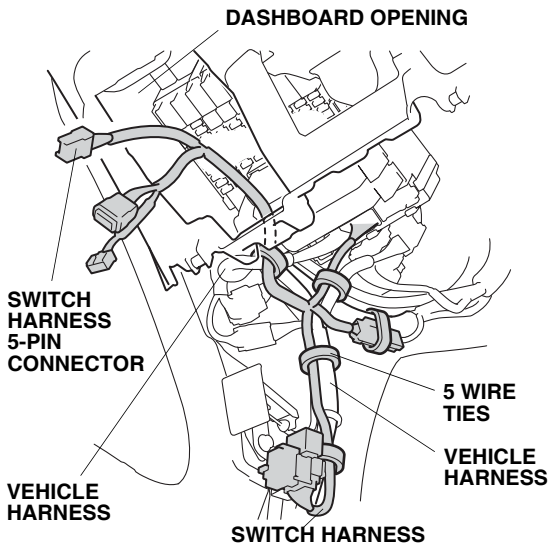

45. Using five wire ties, secure the switch harness to the vehicle harnesses in the areas shown.

**If the vehicle is equipped with ambient lights, go to step 49. Otherwise, continue with step 46.**

46. Unplug the vehicle 13-pin connector from the mirror switch connector, and plug it into the switch harness 13-pin connector with urethane cushion. Plug the other switch harness 13-pin connector into the mirror switch 13-pin connector.

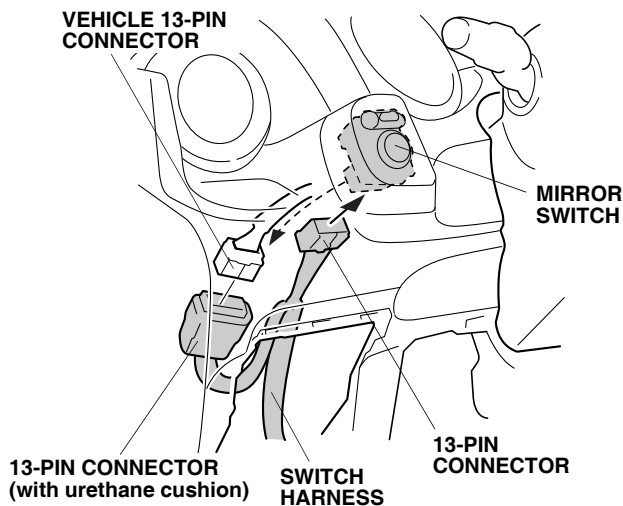

47. Using one wire tie, secure the excess fog light harness and connector to the vehicle harness.

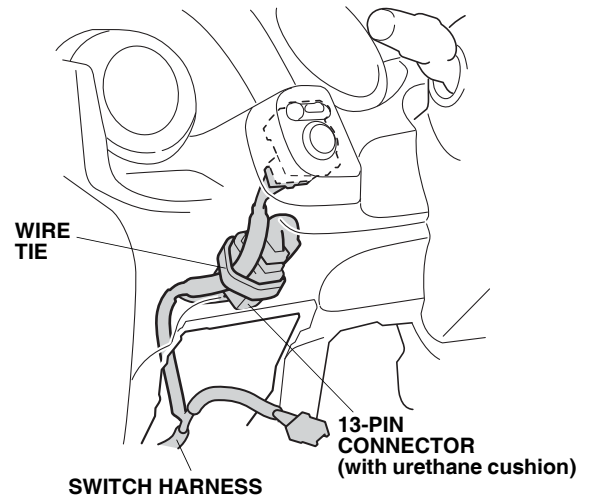

48. Go to step 51.

49. Unplug the vehicle 13-pin connector from the ambient light harness, and plug it into the switch harness 13-pin connector with urethane cushion. Plug the other switch harness 13-pin connector into the ambient light harness connector.

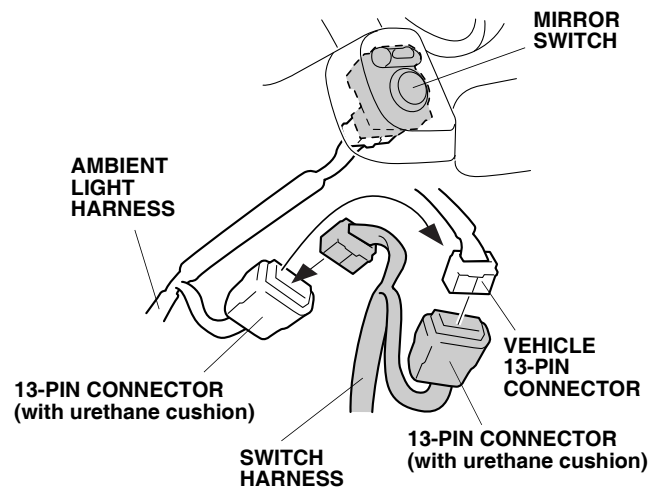

50. Secure the two 13-pin connectors to the ambient light harness using one wire tie for each connector.

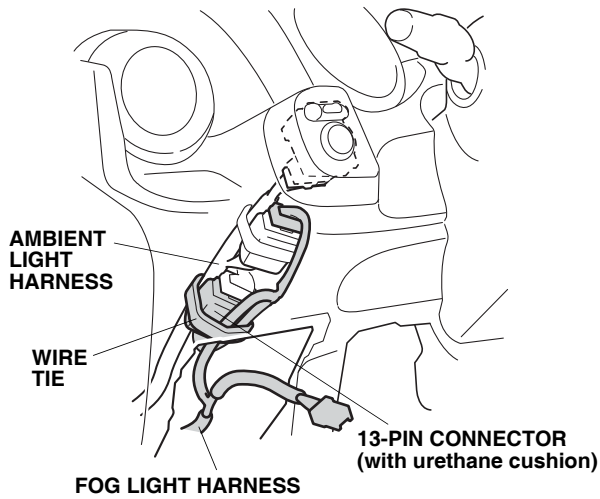

### Installing the Fog Light Switch

51. Remove the left blank cover from the fuse access panel.

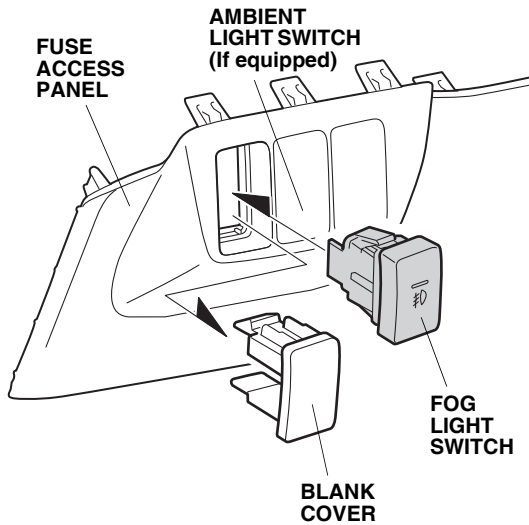

52. Install the fog light switch into the fuse access panel. **If the vehicle is equipped with ambient lights, go to step 57; otherwise, continue with step 53.**

53. Install one wire tie with clip to the switch harness in the position shown.

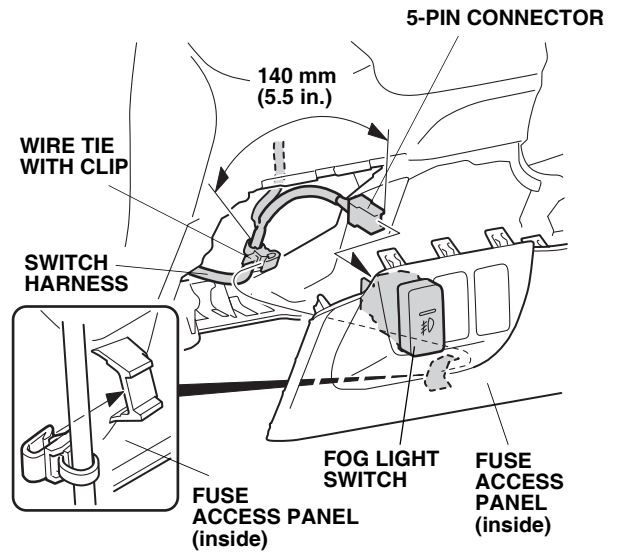

54. Plug the switch harness 5-pin connector to the fog light switch.
55. Attach the wire tie with clip to the clip holder on the inside of the fuse access panel.
56. Reinstall the fuse access panel and go to step 61.
57. Using one wire tie, secure the switch harness to the ambient light harness.

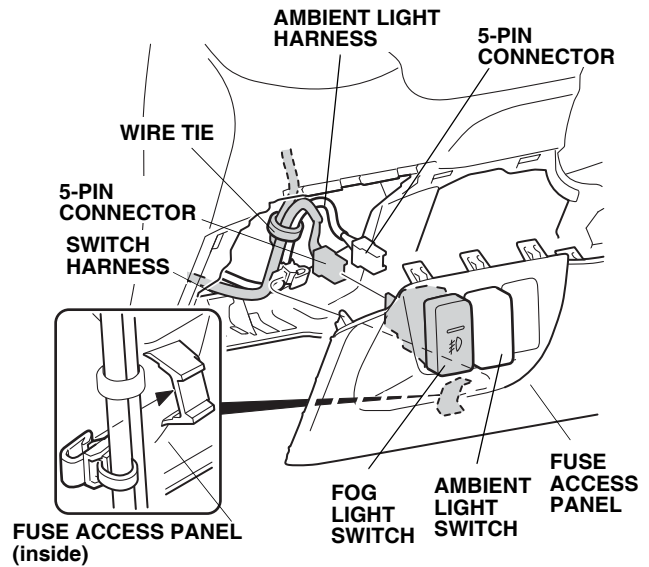

58. Plug the switch harness 5-pin connector and the ambient light harness 5-pin connector to the fog light switch and the ambient light switch.
59. Attach the wire tie with clip to the clip holder on the inside of the fuse access panel.
60. Reinstall the fuse access panel.
61. Check that all wire harnesses are routed properly and all connectors are plugged in.
62. Reinstall all removed parts.
63. Connect the negative cable to the battery and check the operation of the fog lights.
64. Enter the anti-theft codes for the audio system and the navigation system (if equipped).
65. Reset the clock on the vehicles without navigation.

## USE AND CARE

### How to Operate Fog Lights

- Turn the light switch to the “☰☉” position (headlights on low beam).
- Press the fog light switch (indicator is on).

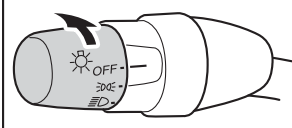

		HEADLIGHT SWITCH			
		OFF	☰☉	☰☉	
				Low	High
INDICATOR ☰☉	FOG LIGHT SWITCH	OFF	-	-	-
		ON	-	ON	-

**NOTE:** The fog light lenses can cloud when the outside temperature is cold; this is normal and should go away in warm weather.

## Fog Light Aiming Adjustment

- Adjust the aim according to local laws and regulations.
- To adjust, turn the aiming adjustment screw in or out until the correct aim is obtained.

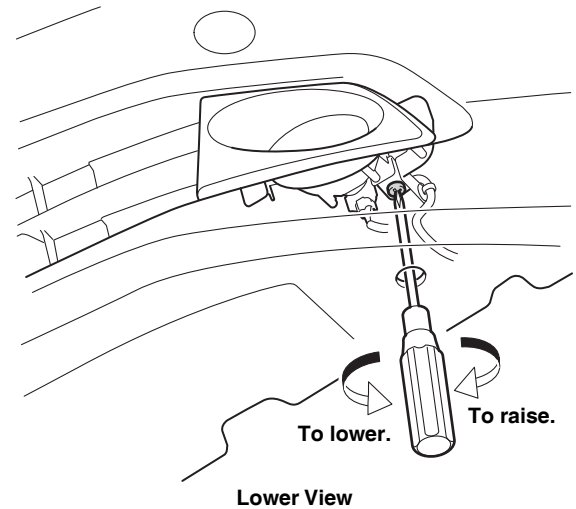

## BULB REPLACEMENT

1. Remove the self-tapping screw and the clip, and then move the inner fender out of the way.

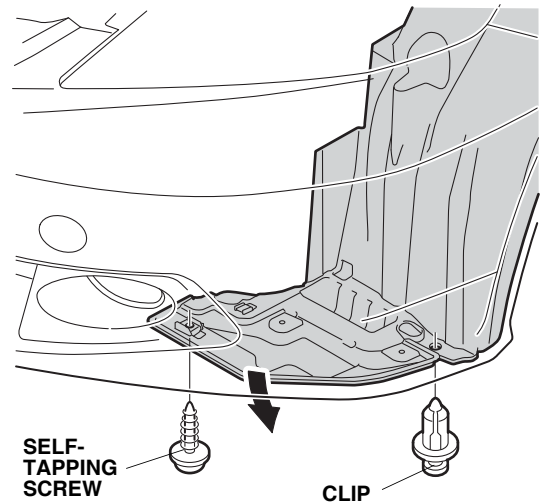

2. Unplug the fog light connector.

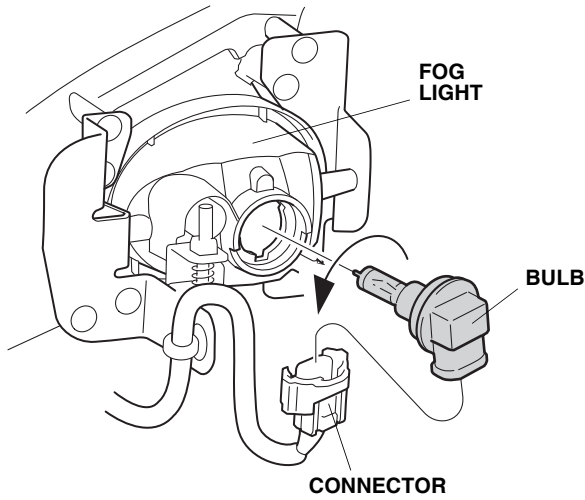

3. Remove the bulb by turning the bulb counterclockwise.

4. Install the new bulb into the fog light.

- When replacing the fog light bulb, be careful not to damage the lenses or the painted surface of the bumper.
- Use only a Honda Genuine halogen light bulb of specified wattage.  
Rating: 12V 55W H11 Halogen Light Bulb  
P/N 33165-S5A-003
- Do not touch the bulb. Oily or greasy substances on the bulb can shorten its service life due to the heat produced when the bulb is turned on. If the bulb is accidentally touched, wipe it clean with a soft cloth that has been dampened with a denatured alcohol or a mild detergent solution.
- When installing the new bulb, align the cutout on the fog light with the tab on the new bulb and turn the new bulb in completely. If not properly aligned, the fog light may blind oncoming drivers.

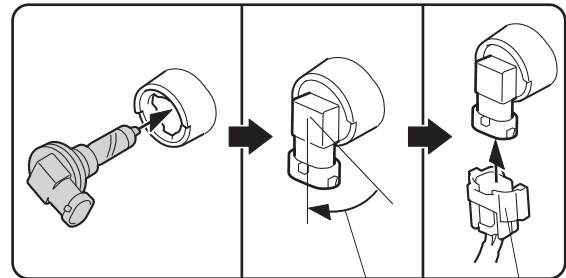

Turn the bulb until it stops.

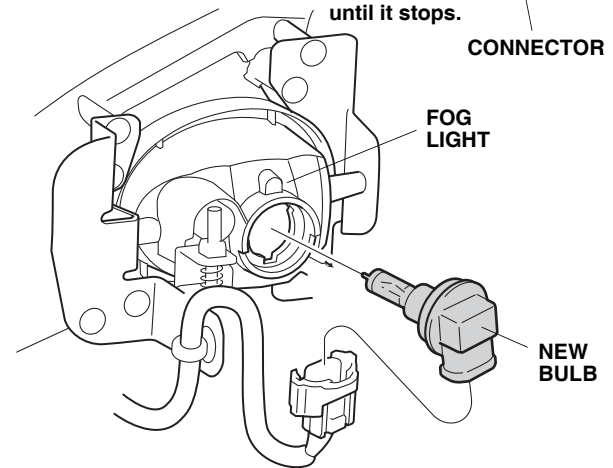

5. Reinstall the removed parts. Check that the wire harnesses are not pinched. Be sure to tighten the clips securely.
6. Check the operation of the fog light; adjust the aim if necessary.