



INSTALLATION INSTRUCTIONS

Accessory
16" ALUMINUM WHEEL
P/N 08W16-TK6-100

Application
2011 FIT

Publications No.
All 45031
Issue Date
NOV 2010

PARTS LIST

Aluminum wheel
(The illustration may differ from the Honda wheel.)



Center cap



Tire pressure information label

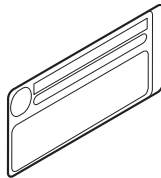

Supplemental information

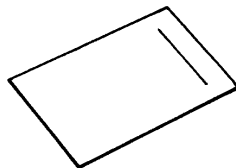

TPMS Information
(Give this information to your customer.)

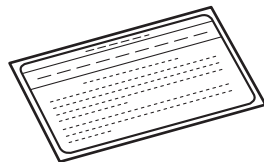

Washer



Valve nut

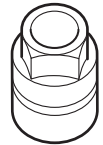

TOOLS AND SUPPLIES REQUIRED

- Ratchet
- 11 mm Socket
- Torque wrench
- Isopropyl alcohol
- Shop towel
- HDS
- Snap-on TPMS sensor initializer tool (T/N AKS0620006)

SPECIFICATIONS

Rim size	16 x 6.5 J (offset 553)	
Tire size	185/55R16 83H	
Bolt hole PCD	100 (4 holes)	
Tire pressure	Front	230kPa (2.3 kgf/cm ² , 33 psi)
	Rear	230kPa (2.3 kgf/cm ² , 33 psi)

INSTALLATION

Customer Information: The information in this installation instruction is intended for use only by skilled technicians who have the proper tools, equipment, and training to correctly and safely add equipment to your vehicle. These procedures should not be attempted by “do-it-yourselfers.”

NOTE:

- This aluminum wheel is designed for use on vehicles equipped with a TPMS (Tire Pressure Monitoring System).
- This aluminum wheel is equipped with a TPMS sensor. See the service manual for the tire replacement procedure and TPMS sensor installation procedure.
- The illustrations of the aluminum wheels are shown for reference purposes only.
- Install the correct size tire.
- The wheel nut torque is 108 N·m (80 lbf·ft).
- Use a tire changer to install and remove the tires. Do not use a tire lever to install and remove the tires, as it may cause damage to the tire and aluminum wheel.
- The standard wheel nuts cannot be used with the aluminum wheels. Replace them with the correct wheel nuts, which are sold separately.

Wheels with plastic cover

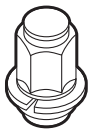

Aluminum wheels



1. Before installing the tire pressure sensor, clean the mating surfaces on the sensor and the aluminum wheel.

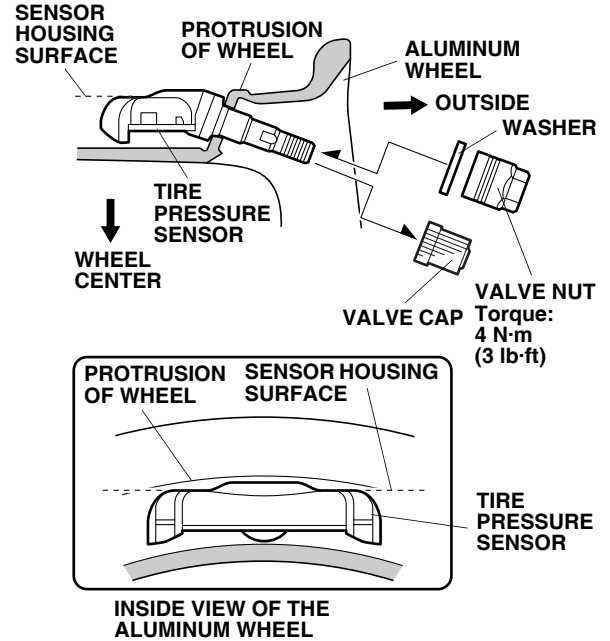

2. Remove the valve cap. Install the tire pressure sensor and the washer to the wheel, and tighten the valve nut finger tight. Make sure the pressure sensor is resting on the wheel.

NOTE: Install the tire pressure sensor so that the sensor housing surface does not protrude into the bead area of the wheel. This prevents the sensor housing from being caught on the bead of the tire when installing the tire.

3. Torque the valve nut to 4 N·m (3 lbf·ft) while holding the tire pressure sensor toward the wheel. Reinstall the valve cap.

NOTE:

- Do not reuse torqued grommets; the valve system may leak.
 - Do not use pneumatic or electric tools on the valve nut.
 - Tightening the nut above the specified torque can damage the grommet.
4. Install the tires according to the instructions in the service manual.
 5. Install the wheels on the vehicle and torque the wheel nuts to 108 N·m (80 lbf·ft).

- Open the driver's door. Using isopropyl alcohol, thoroughly clean the area where the Tire Pressure Information Label will attach. Remove the adhesive backing from the label, and attach it on the vehicle caution label as shown.

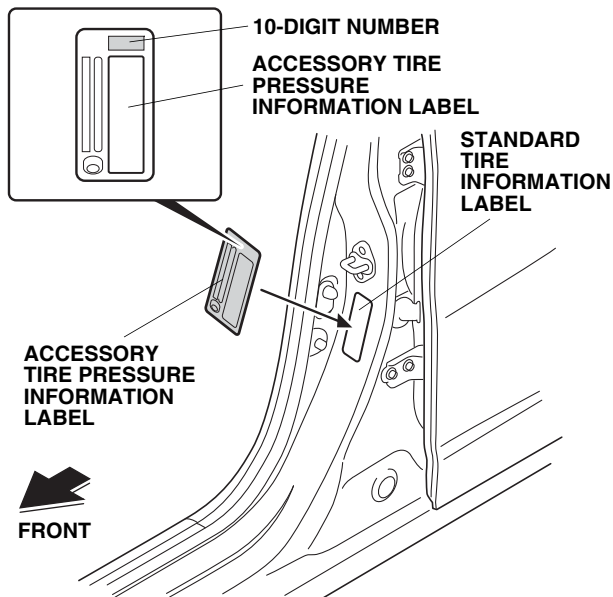

- Insert the Supplemental Information page into the owner's manual.

MEMORIZING THE TIRE PRESSURE SENSOR ID

- Using the HDS TPMS sensor initializer tool, memorize the ID of the tire pressure sensor according to the instructions in the service manual (Memorizing the Tire Pressure Sensor ID).

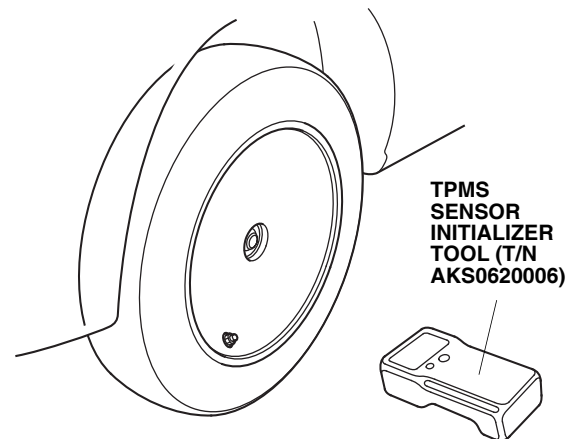
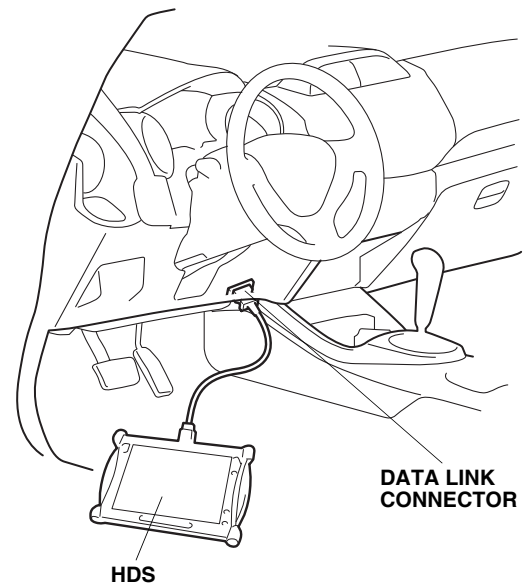

- If necessary, do the Inch-up Tire Pressure programming procedure on page 4.
- Write the tire size, tire pressure, HDS version, dealer name, technician's signature, and date on the service history page for Honda Accessory Wheels, and attach the page to the vehicle's service history booklet.

- Be sure to explain the contents of the Supplemental Information to your customer before delivering the vehicle.
- Be sure to give the TPMS information to your customer.

INCH-UP TIRE PRESSURE PROGRAMMING (LOW AIR PRESSURE WARNING THRESHOLD REPROGRAMMING)

1. After doing the sensor ID learning using the HDS, back up to the TPMS Mode Menu, and click on Threshold Rewriting.
2. Select "Reprogramming for accessory tires".
3. When the HDS says, "Do you want to rewrite the threshold data?" click "YES".
4. "Please enter the tire information code of new tires" will appear. Click the "Keyboard" icon.
5. Enter the 10-digit tire information code printed on the new tire pressure information label, then click the check icon.
6. Check that the tire pressure shown on the HDS and the new tire pressure on the tire information label are the same, then click "YES".
7. Check that the current air pressure setting shown on HDS is correct and that the display says "Reprogramming the threshold data for non-standard tires has completed successfully".
8. After programming, write the tire pressure indicated on the HDS on the service history page for Honda Accessory Wheels, then click the check icon.
9. After programming, sign the service history page for the Honda Accessory wheels.

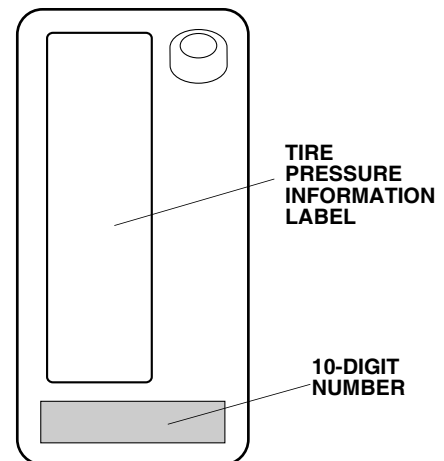
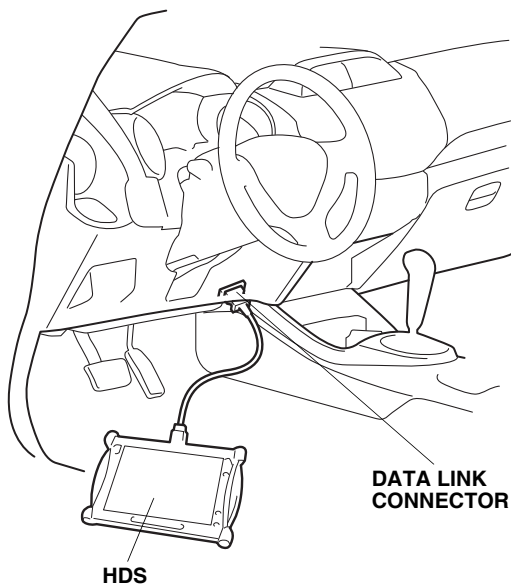

TPMS UNIT REPLACEMENT

If the TPMS unit is replaced, redo Inch-Up Tire Pressure Programming and Tire Pressure ID Memorization.

REINSTALLING STANDARD WHEELS

If the original equipment (standard) wheels are reinstalled on the vehicle, the low tire pressure warning threshold must be restored to the factory setting, following the procedure below.

NOTE: Have the standard tire pressure label on hand.

STANDARD TIRE PRESSURE PROGRAMMING

To return the TPMS programming from the inch-up tire to the standard tire, change the programming:

1. Connect the HDS to the vehicle, make sure the correct VIN is populated, and enter the mileage.
2. At the System Selection Menu, click TPMS.
3. At the Mode Menu, click on DTCs and clear any stored codes.
4. Go back to the Mode Menu, and click on Threshold Rewriting.
5. Click on Reprogramming for standard tires, and follow the screen prompts.
6. After programming, write the standard tire pressure in the Supplemental Information page, then click the check button.
7. Attach the standard tire pressure information label over the old label in the driver's doorjamb.
8. Sign the service history page for Honda Accessory Wheels.

Write the tire size, tire pressure, HDS version, dealer name, technician's signature, and date on the service history page for Honda Accessory Wheels.

THRESHOLD DATA CHECK

If you are unsure where the low tire pressure warning threshold is set, do the following:

1. Connect the HDS to the vehicle and make sure the correct VIN is populated, and enter the mileage.
2. At the System Selection Menu, click TPMS.
3. Click on Threshold Rewriting.
4. Click on Threshold Data Check.

