



INSTALLATION INSTRUCTIONS

Accessory

16" ALUMINUM WHEEL
P/N 08W16-SNA-100A

Application

2011 CIVIC
2- AND 4-DOOR

Publications No.

All 44334

Issue Date

AUG 2010

PARTS LIST

Aluminum wheel
(The illustration may differ from the actual wheel.)

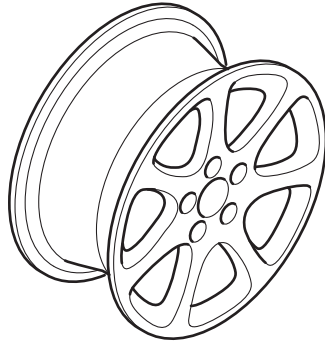

Center cap

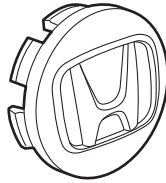

Grommet



TOOLS AND SUPPLIES REQUIRED

Ratchet
11 mm Socket
Torque wrench
Isopropyl alcohol
Shop towel
HDS (Honda Diagnostic System)
Snap-on TPMS sensor system initializer tool

INSTALLATION

Customer Information: The information in this installation instruction is intended for use only by skilled technicians who have the proper tools, equipment, and training to correctly and safely add equipment to your vehicle. These procedures should not be attempted by "do-it-yourselfers."

NOTE:

- This aluminum wheel is designed for use on a vehicle equipped with TPMS (Tire Pressure Monitoring System).
- This aluminum wheel is equipped with a TPMS sensor. See the service manual for the tire replacement procedure and TPMS sensor installation procedure.
- The illustration of the aluminum wheels are shown for reference purposes only.
- Install the correct size tire.
- Use a tire changer to remove and install the tires. Using tire levers to remove and install the tires can damage to the tire, the wheel, and the TPMS sensor.
- The wheel nut torque is 108 N·m (80 lbf·ft).
- The standard wheel nuts can not be used with the aluminum wheels. Replace them with the correct wheel nuts which are sold separately.

for wheels with cap



for aluminum wheels



1. Remove the valve stem nut and washer, then remove the tire pressure sensor from the wheel.

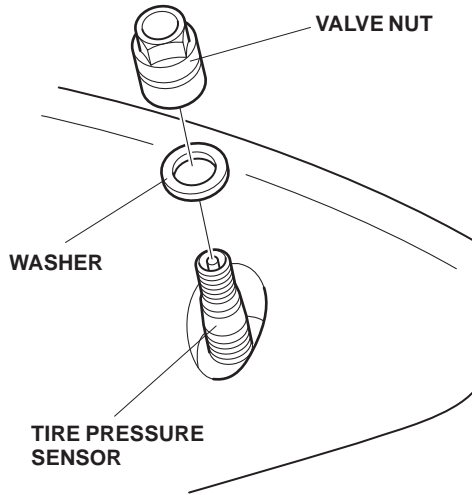

2. Remove and discard the grommet from the tire pressure sensor.

NOTE: If the grommet is missing from the tire pressure sensor, make sure it is not stuck in the wheel.

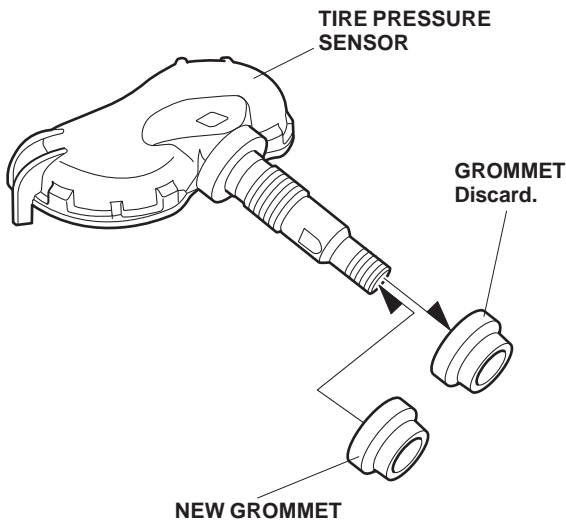

3. Install the new grommet onto the tire pressure sensor.
4. Clean the mating surface and the valve hole in the aluminum wheel.

5. Install the tire pressure sensor and the washer to the aluminum wheel, and loosely install the valve nut. Make sure the pressure sensor is resting on the wheel.

NOTE: Install the tire pressure sensor so that the sensor housing surface does not exceed the wheel protrusion.

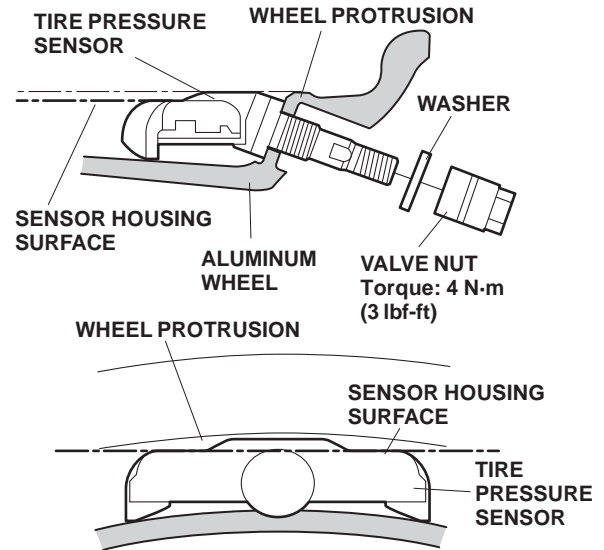

VIEWED FROM THE INSIDE OF THE ALUMINUM WHEEL

6. Torque the valve nut to 4 N·m (3 lb-ft) while holding the tire pressure sensor against the wheel.

NOTE:

- Do not reuse a torqued grommet, or the valve stem may leak.
- Do not use pneumatic or electric tools on the valve nut.
- Tightening the nut to above the specified torque can damage the grommet.

7. Install the tires according to the instructions in the service manual.
8. Install the wheels on the vehicle and torque to 108 N·m (80 lb-ft).

TIRE PRESSURE SENSOR LOCATIONS

- Using the HDS and the Snap-on TPMS sensor initializer tool, register the TPMS sensor locations in order of ①, ②, ③ and ④ according to "Tire Pressure Sensor Location" in the service manual.

