

PARTS LIST

Front under spoiler

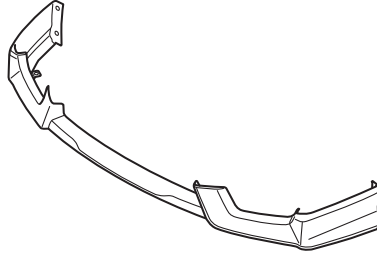

4 Self-tapping screws



4 Spring nuts



Spacer

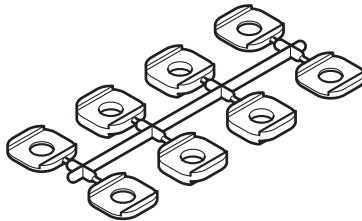

4 Clip retainers



4 Sponge seals



2 EPDM sponges



2 Clips

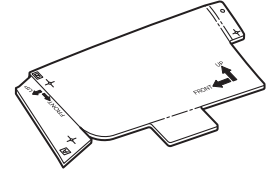

Template

**TOOLS AND SUPPLIES REQUIRED**

Phillips screwdriver

Clip remover

Eye protection (face shield, safety goggles, etc.)

Drill

3 mm, 10 mm, and 12 mm Drill bits

Rubber roller (EQSE54D)

File

Pushpin

Masking tape

Shop towel

Isopropyl alcohol

Tape

Diagonal cutters

Scissors

INSTALLATION

Customer Information: The information in this installation instruction is intended for use only by skilled technicians who have the proper tools, equipment, and training to correctly and safely add equipment to your vehicle. These procedures should not be attempted by “do-it-yourselfers.”

NOTE:

- Can not install with nose mask.
- Using isopropyl alcohol on a shop towel, thoroughly clean the area where the front under spoiler will attach. Use a shop towel to apply the isopropyl alcohol and wipe up spills at once. Allow the isopropyl alcohol to dry thoroughly before attaching the front under spoiler.
- Be careful not to damage the body paint finish.
- This front under spoiler kit should be installed only if the ambient air temperature is 15°C (60°F) or above. Heat the front under spoiler and bonding surfaces with a hair dryer set on LOW if the ambient air temperature is lower.
- Wash and wax the area to be covered with a high-quality paste wax.
- To allow the adhesive to cure, do not wash the vehicle for 24 hours.
- For steps 13 and 23, lift up the vehicle.

Without fog lights

With fog lights: Go to step 3.

1. Remove the left cover (four pawls).

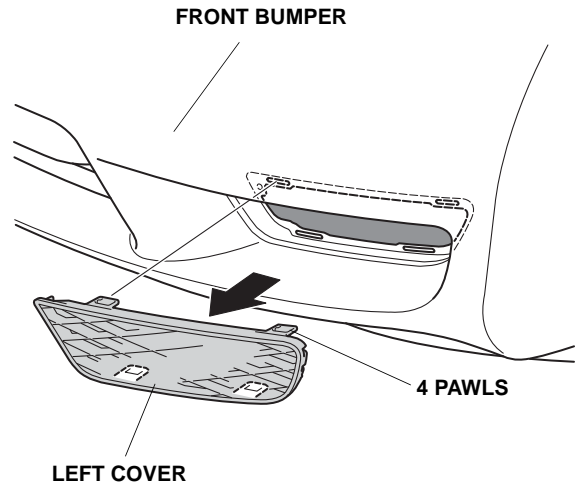

2. Repeat step 1 on the other side. Go to step 6.

With fog lights

3. Remove one self-tapping screw.

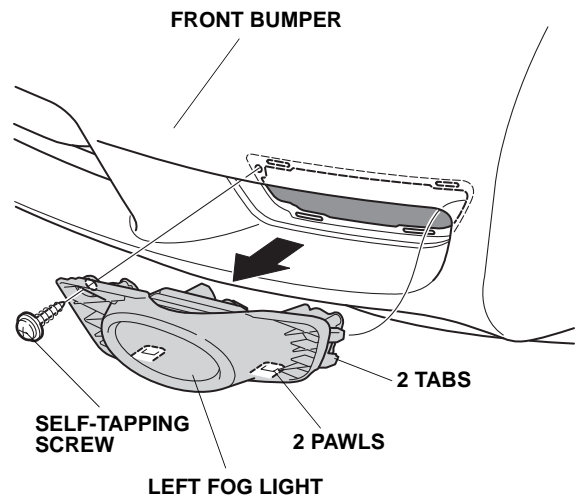

4. Remove the left fog light (two pawls, two tabs, and vehicle connectors).
5. Repeat steps 3 and 4 on the other side.

- Cut the template. Align template B on the front bumper. Using a pushpin, pierce the front bumper to make two marks as shown.

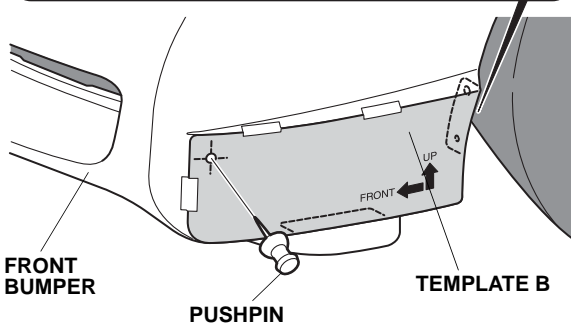
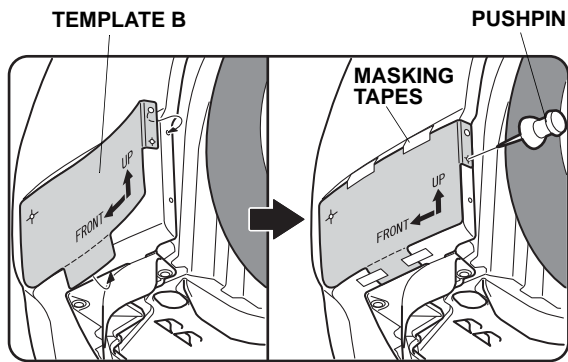
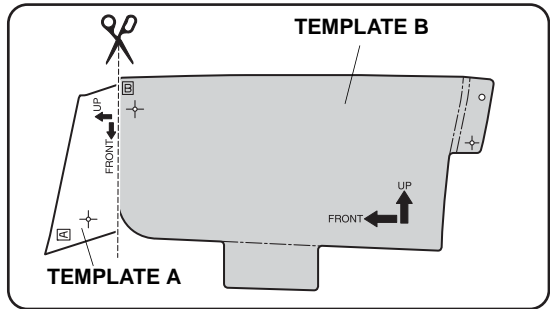

- Remove template B.

- Align template A on the front bumper. Using a pushpin, pierce the front bumper to make one mark as shown.

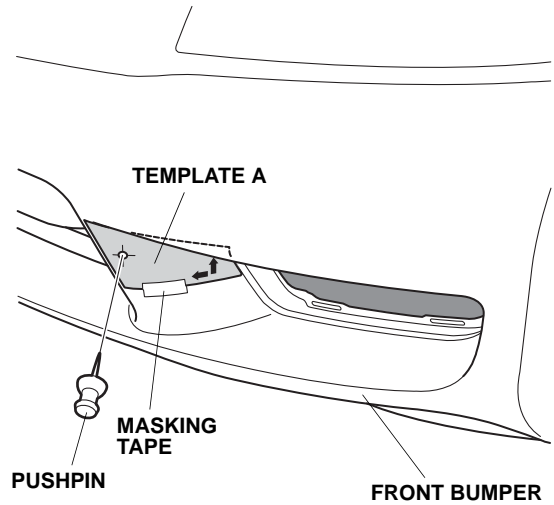

- Remove template A.
- While wearing eye protection, drill a 3 mm hole through the two marks on the front bumper as shown. Finish with a 12 mm bit. Wrap tape around the drill bit 10 mm away from the tip.

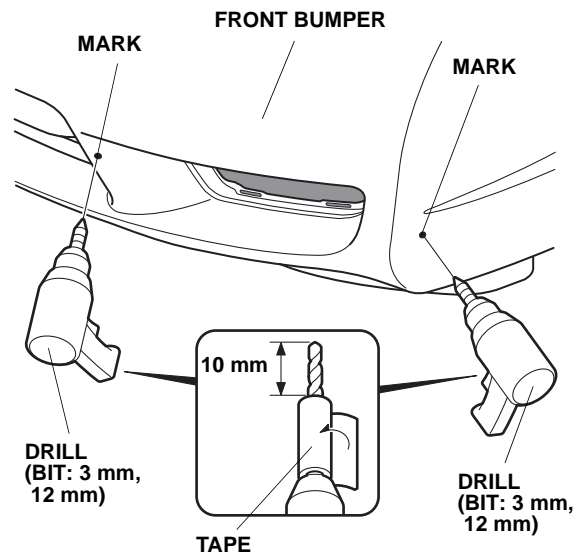

- Remove any burrs from the edge of the hole.
- Reverse templates A and B and repeat steps 6 thru 11 on the other side.

- Turn the steering wheel clockwise.

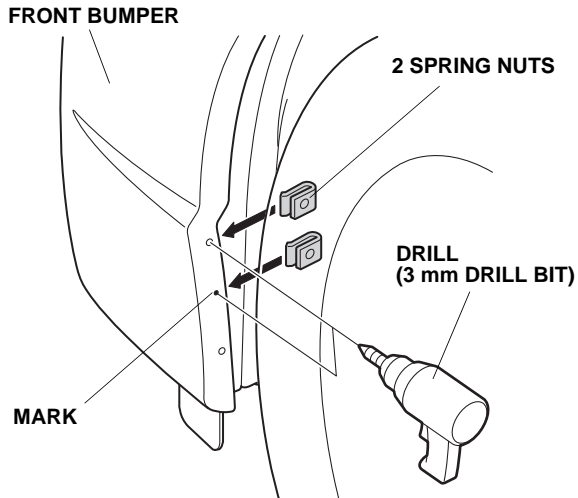

- Drill a 3 mm hole through the center of the two dimpled areas on the front bumper as shown.
- Remove any burrs from the edges of the holes.
- Slide two spring nuts over the two holes drilled in the front bumper.
- Turn the steering wheel counterclockwise. Repeat steps 14 thru 16 on the other side.
- Remove the two clips securing the front bumper.

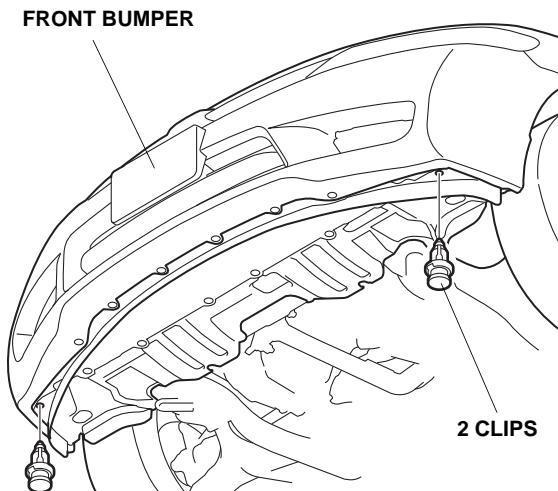

- Attach one sponge seal to each clip on the front under spoiler as shown.

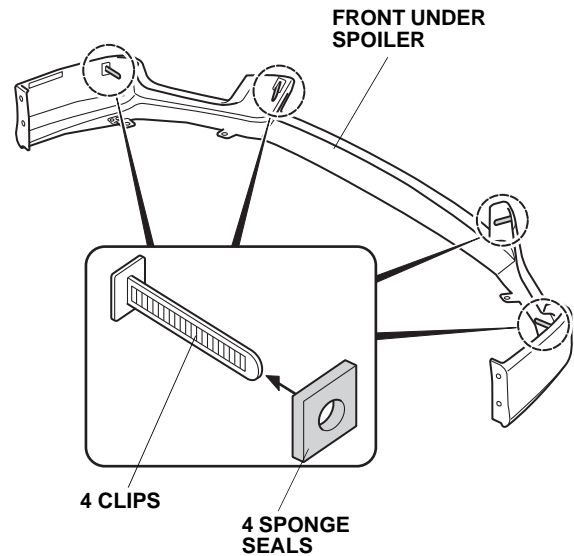

- Attach a strip of masking tape to the end of each backing, and peel back 30 to 40 mm of the backings. Fold the ends back, and tape them to the front of the front under spoiler.

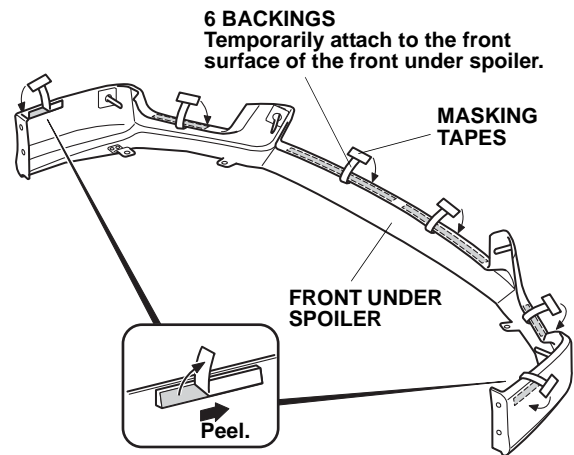

- Using isopropyl alcohol on a shop towel, clean the front bumper where the front under spoiler will attach.

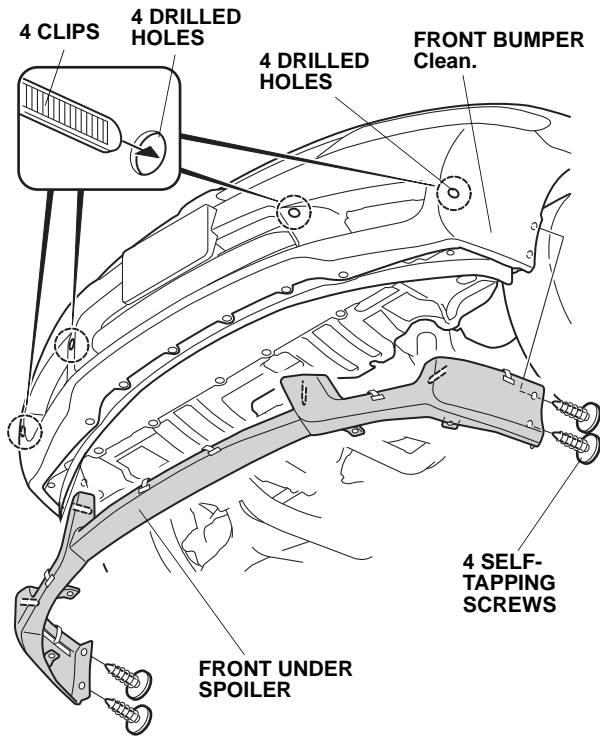

- Position the front under spoiler on the front bumper, and loosely install four self-tapping screws as shown.

- With the vehicle on a lift, use a pushpin to pierce the front bumper to as shown.

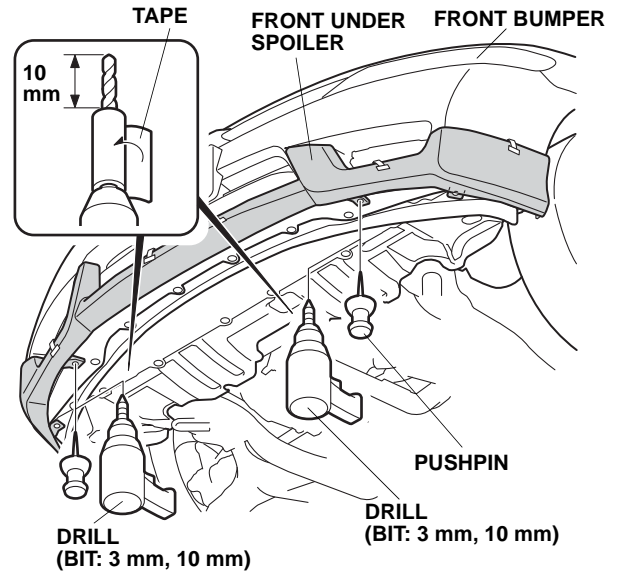

- While wearing eye protection, drill two 3 mm holes through the two marks on the front bumper as shown. Finish with a 10 mm bit. Wrap tape around the drill bit 10 mm away from the tip.
- Attach two new clips and two clips (reuse) as shown.

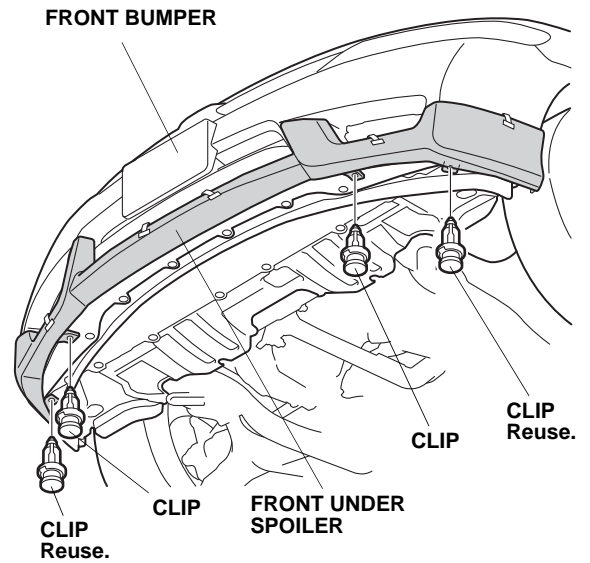

- Lower the vehicle.

27. Attach two EPDM sponges to two clip retainers. Loosely install the two clip retainers to the two clips (inside) on the front under spoiler as shown.

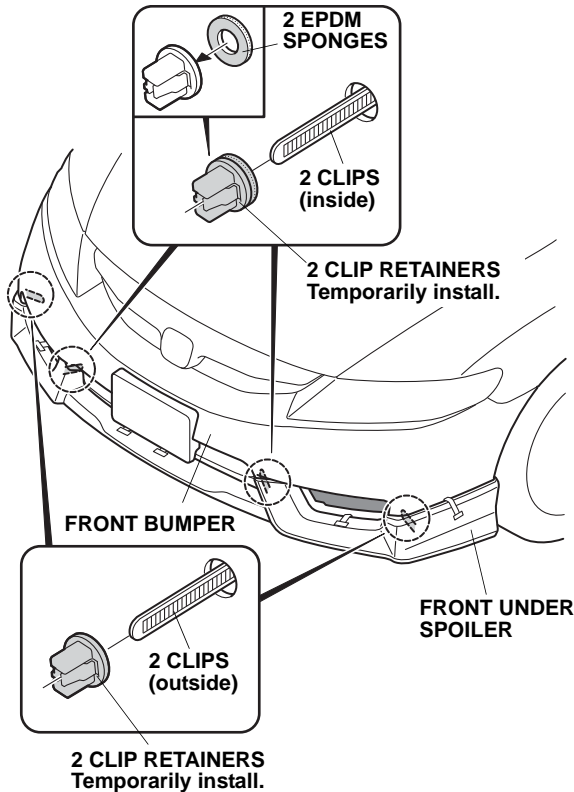

28. Loosely install one clip retainer on each clip (outside) on the front under spoiler as shown.
29. While applying pressure on the front under spoiler, carefully remove the backings in the sequence shown. Hold the front under spoiler firmly against the front bumper with your hands for 30 seconds.

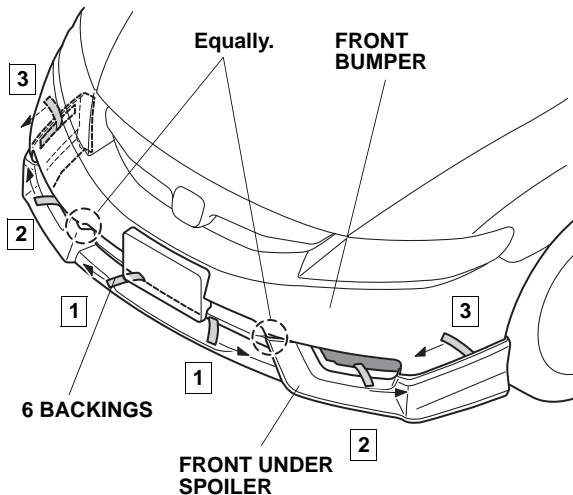

30. Using a rubber roller, apply firm pressure while rolling to set the adhesive.

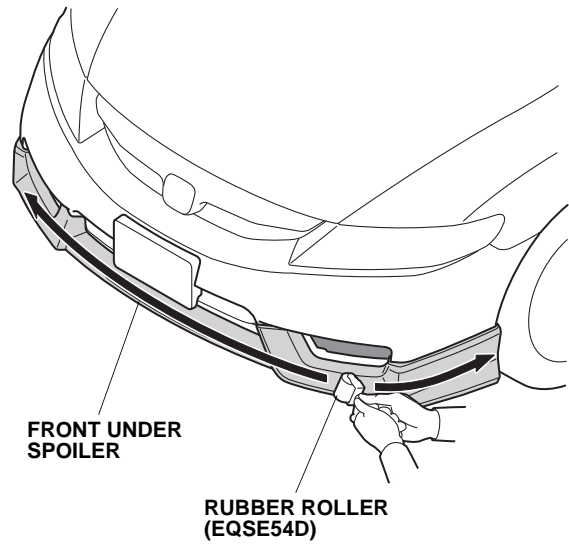

31. Tighten the four self-tapping screws installed in step 22. If necessary, install spacers between the front bumper and the front under spoiler.
- Using a diagonal cutters, cut the spacers apart.
 - Spacer thickness of "1" and "2" represent 1 mm and 2 mm respectively.
 - Do not use the spacers by combining the spacers of "2" together.

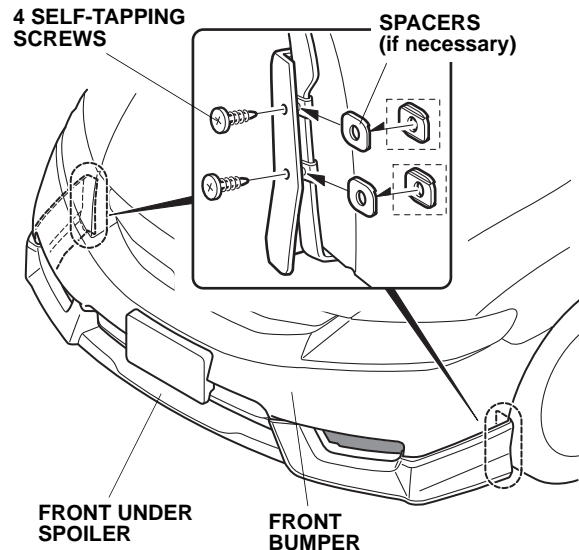

32. Tighten the four clip retainers loosely installed in steps 27 and 28.
33. Reinstall all removed parts.

Give a copy of this page to your customer.

When towing the vehicle, follow the instructions described in the vehicle owner's manual.

