



INSTALLATION INSTRUCTIONS

Accessory
**RUNNING BOARD
P/N08L33-SWA-100**

Application
2011 CR-V

Publications No.
All 44640
Issue Date
AUG 2010

NOTE: Running boards cannot be installed if the vehicle is equipped with front splash guards.

PARTS LIST

Running board (Left)

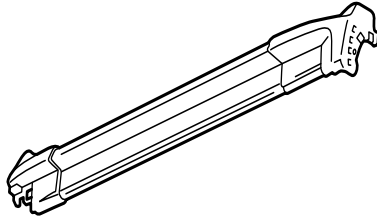

Running board (Right)

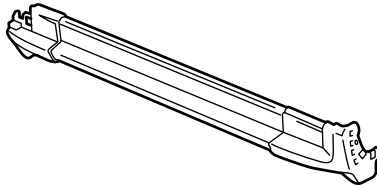

4 Brackets A

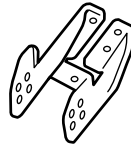

4 Brackets B

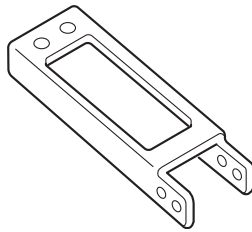

32 Flange bolts, 8 x 20 mm



16 Flange nuts, 6 mm



16 Flange nuts, 8 mm



TOOLS AND SUPPLIES REQUIRED

- Phillips screwdriver
- Clip remover
- Utility knife
- Torque wrench

Illustration of the Running Boards Installed on the Vehicle

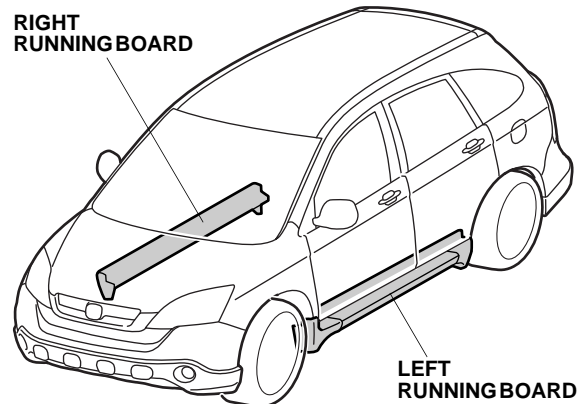

INSTALLATION

Customer Information: The information in this installation instruction is intended for use only by skilled technicians who have the proper tools, equipment, and training to correctly and safely add equipment to your vehicle. These procedures should not be attempted by “do-it-yourselfers.”

NOTE:

- Thoroughly clean the bottom of the body from the rear wheels to the front wheels.
- Be careful not to damage the body paint finish. To prevent damage, place a blanket under the running board during the installation.
- These instructions show the left running board being installed; the same procedure applies to installing the right running board.

1. Turn the steering wheel all the way counterclockwise.

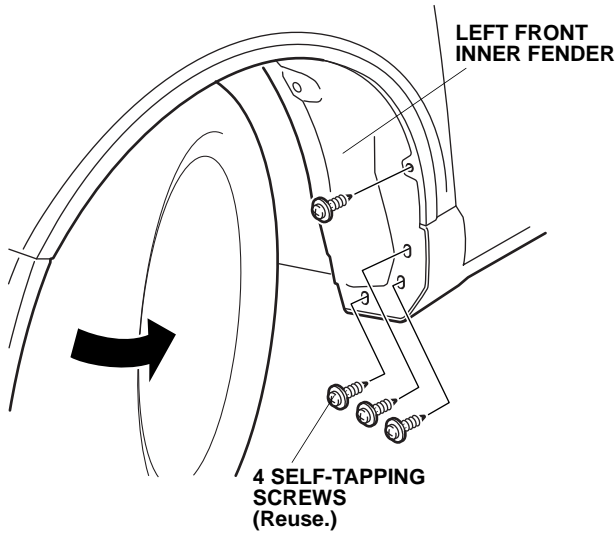

2. Remove and retain the four self-tapping screws from the left front inner fender.
3. Remove and retain the two self-tapping screws from the left rear inner fender.

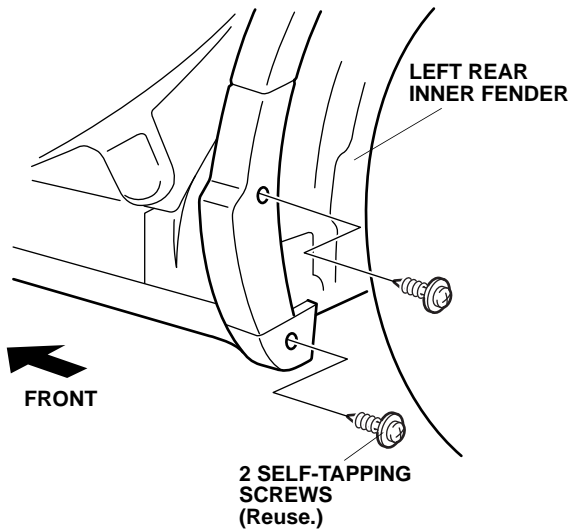

4. Remove the four clips under the left side sill panel.

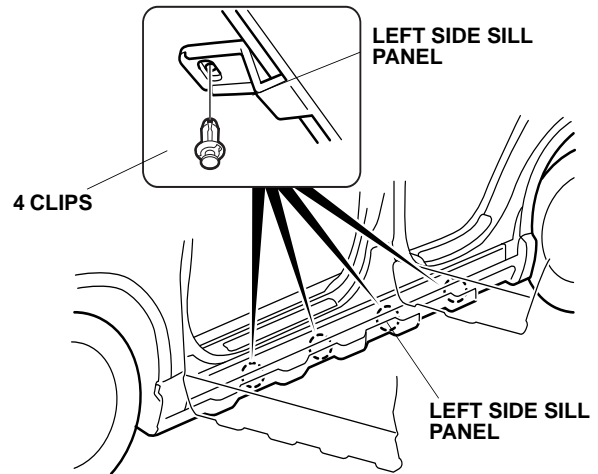

5. Pull out on the left rear wheel arch protector to release the clip.

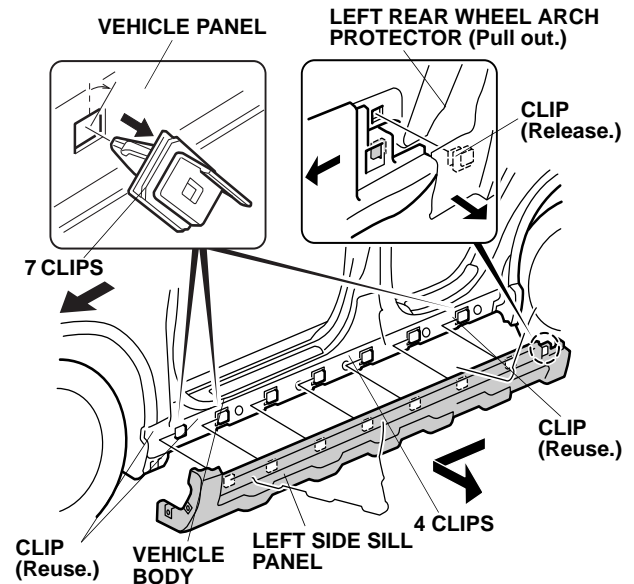

6. With the left rear wheel arch protector pulled away from the side sill trim, slide the left side sill trim forward to release the five retaining tabs and two clips. Remove the left side sill trim.
7. Remove three side sill trim clips, two at the front and one at the rear.

- Remove the left undercover from under the vehicle (four clips and three bolts).

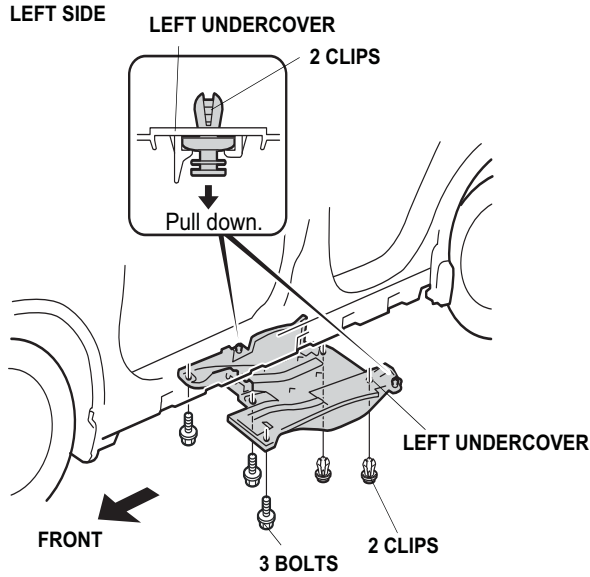

- Remove the right undercover the same way.

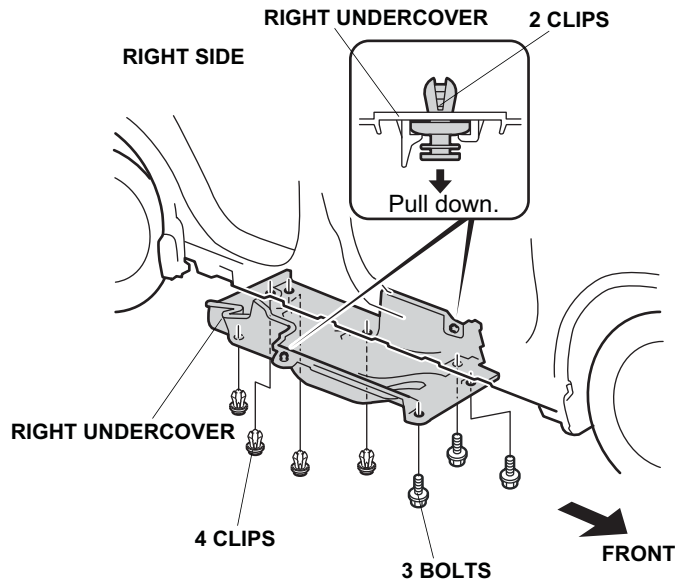

- Using a utility knife, cut out the left undercover along the mark on the inner side of the undercover. Remove any burrs.

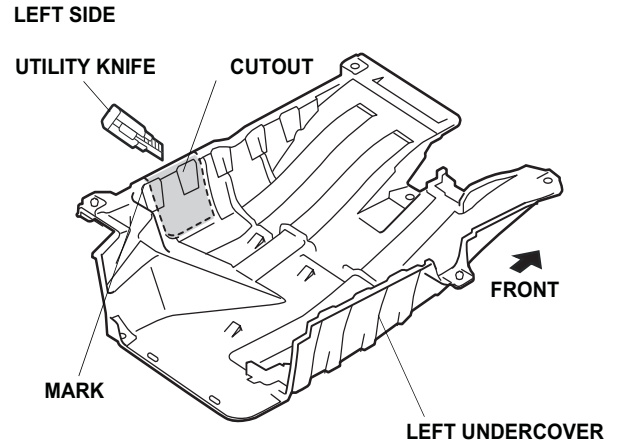

- Cut out the right undercover the same way.

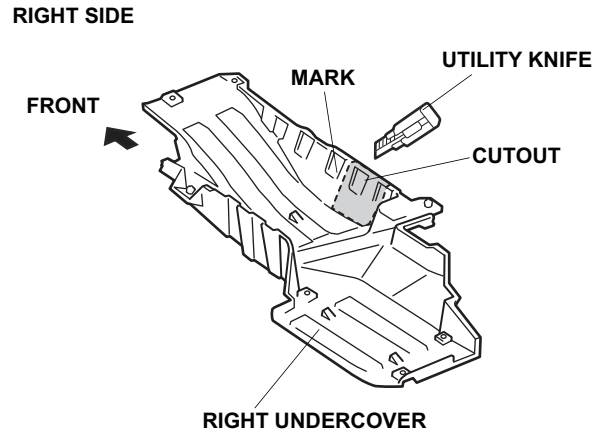

- Remove the bracket from the left side sill panel (two self-tapping screws).

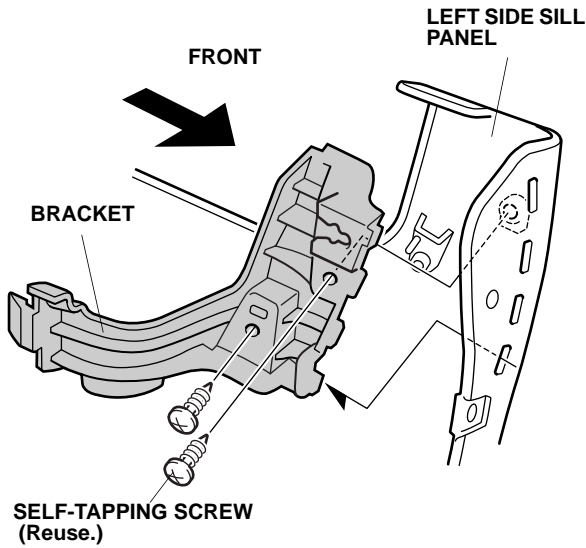

- Install the bracket to the left running board with one of the screws removed in the above step.

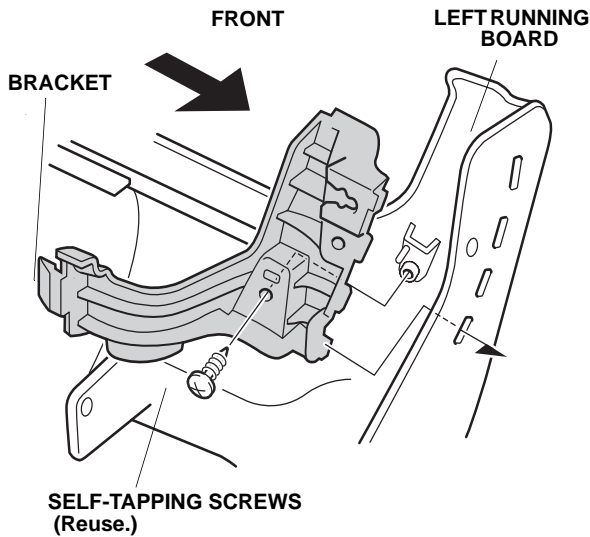

- Remove the two spring nuts from the left side sill panel and install them on the left running board in the areas shown.

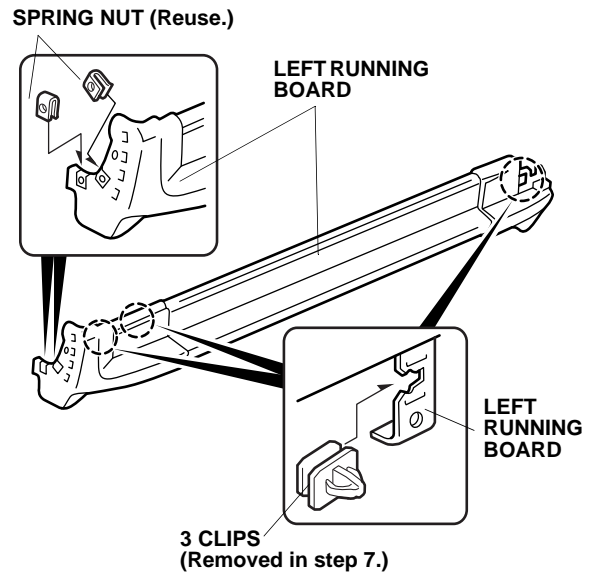

- Install the three clips (removed in step 7) into position on the left running board.
- Position the two brackets A on the left running board by aligning the holes in brackets A with the bolts on the running board. Secure brackets A with eight 6 mm flange nuts, but don't tighten them at this time.

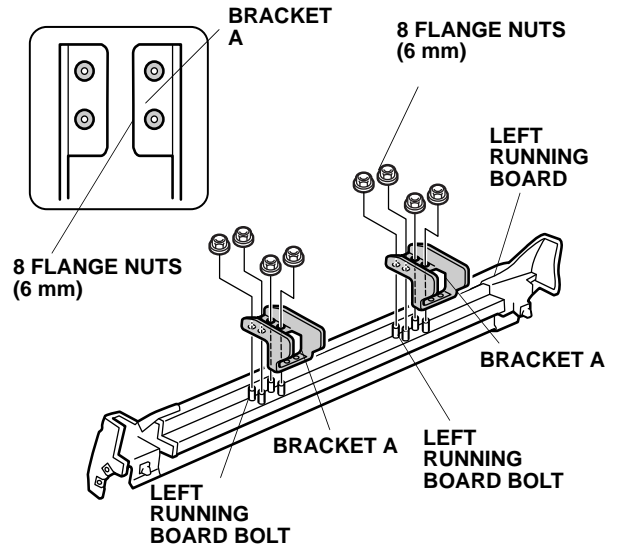

17. Position the left running board on the vehicle, and secure both brackets A using four flange bolts. Make sure the inner fender fits on the inside of the left running board end cap. Align the clips installed in step 15 to the holes in the body panel, and push them into position.

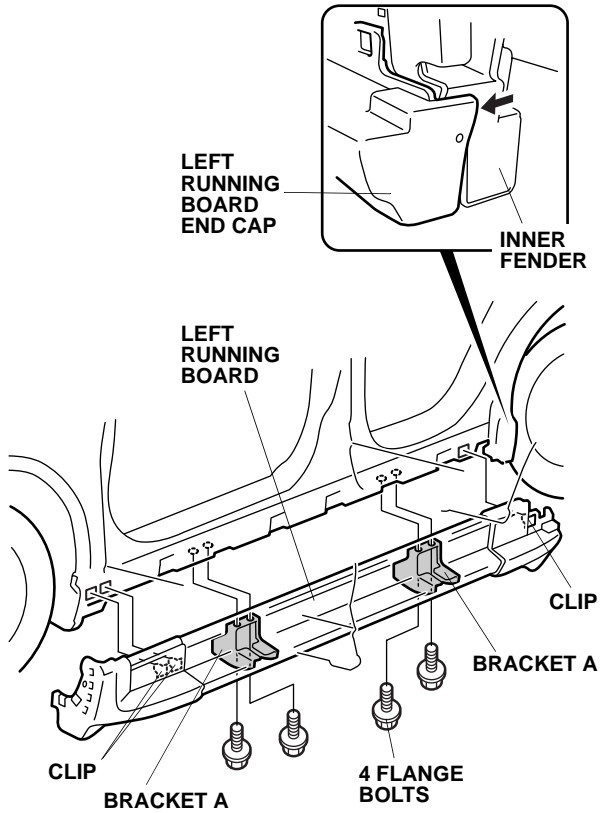

18. Position each bracket B on the vehicle, and secure each bracket with two flange bolts.

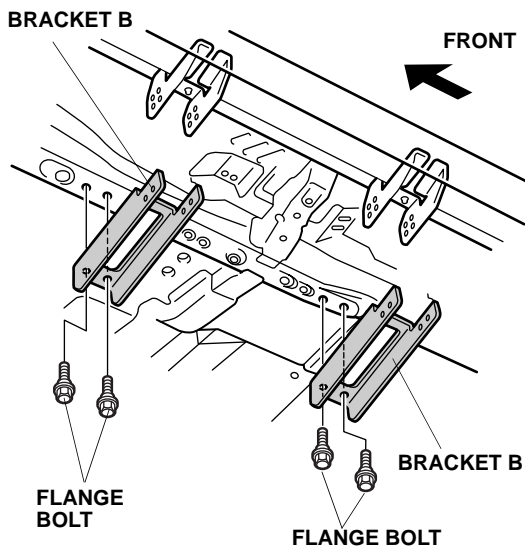

19. Secure brackets A and B together using eight flange bolts and eight 8 mm flange nuts.

Front brackets: Assemble by aligning the hole in bracket B with the lower hole in bracket A.

Rear brackets: Assemble by aligning the hole in bracket B with the upper hole in bracket A.

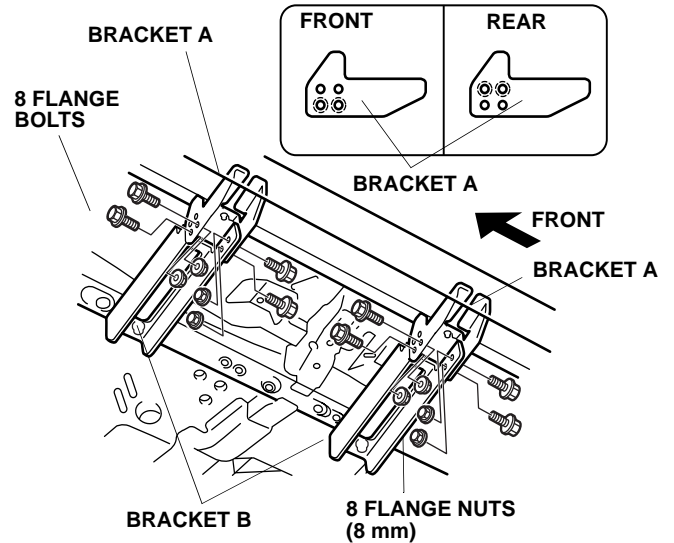

20. Gently pull out on the front wheel arch protector to release the clip, then install the front of the left running board under the inner front fender using the four self-tapping screws removed in step 2.

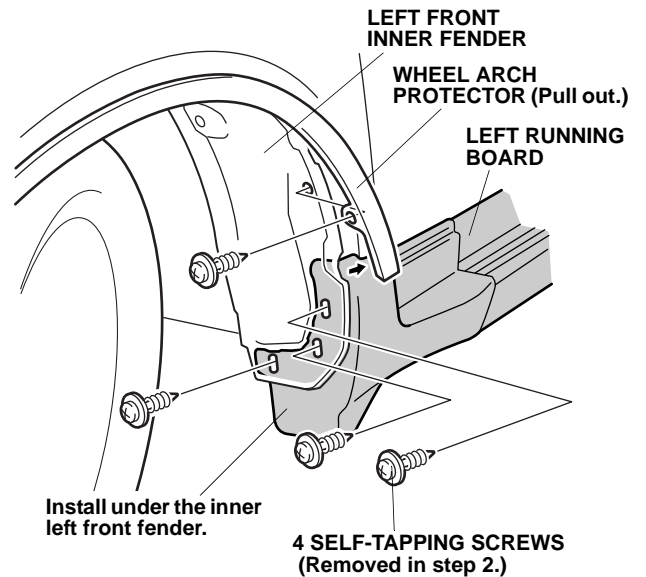

21. Attach the left rear wheel arch protector to the running board. Secure the running board using the two self-tapping screws removed in step 3.

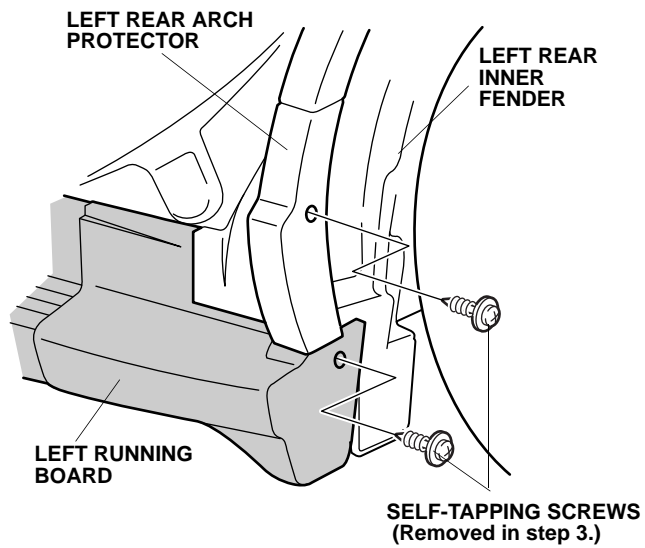

22. Repeat steps 1 thru 21 to install the right running board on the right side of the vehicle.
23. Reinstall the undercovers.