



# INSTALLATION INSTRUCTIONS

Accessory  
**AUTOMATIC DAY/NIGHT MIRROR**

Application  
**2011 CR-V**

Publications No.  
**All 44610**  
Issue Date  
**AUG 2010**

## PARTS LIST

**Automatic Day/Night Mirror Attachment Kit**  
**P/N 08V03-SWA-100**

Harness cover set

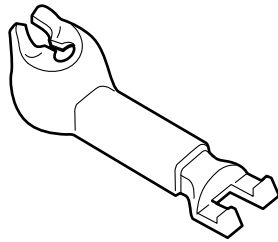

Automatic Day/Night mirror harness

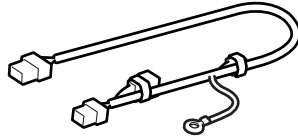

9 Wire ties

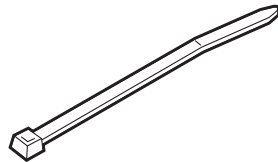

4 EPT sealers

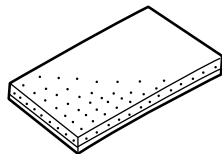

Clip



Ground bolt

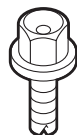

**Automatic Day/Night Mirror Kit**  
**P/N 08V03-S9A-100B**

Day/Night mirror

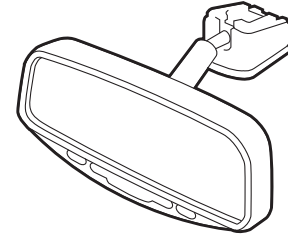

Operating Instructions



## TOOLS AND SUPPLIES REQUIRED

Phillips screwdriver

Flat-tip screwdriver

Ratchet

10 mm Socket

Isopropyl alcohol

Shop towel

Diagonal cutters

T-20 and T-25 TORX bits

Needle nose pliers

Steel wire

## Illustration of the Day/Night Mirror Installed on the Vehicle

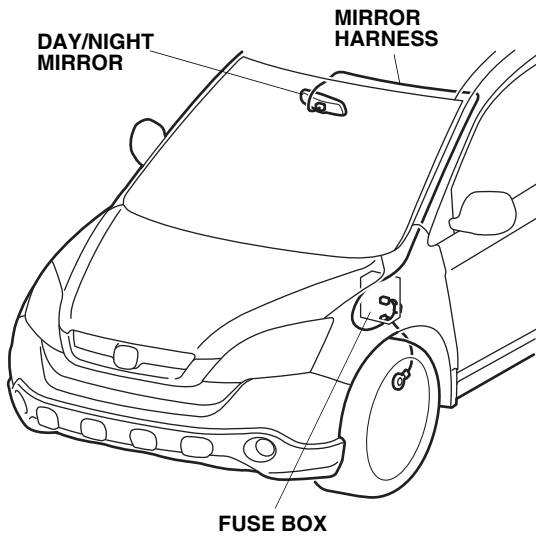

## INSTALLATION

**Customer Information:** The information in this installation instruction is intended for use only by skilled technicians who have the proper tools, equipment, and training to correctly and safely add equipment to your vehicle. These procedures should not be attempted by “do-it-yourselfers.”

1. Make sure you have the anti-theft code for the radio, then write down radio station presets.
2. Disconnect the negative cable from the battery.

3. Carefully remove the right and left map light lenses from the roof console (four tabs for each lens).

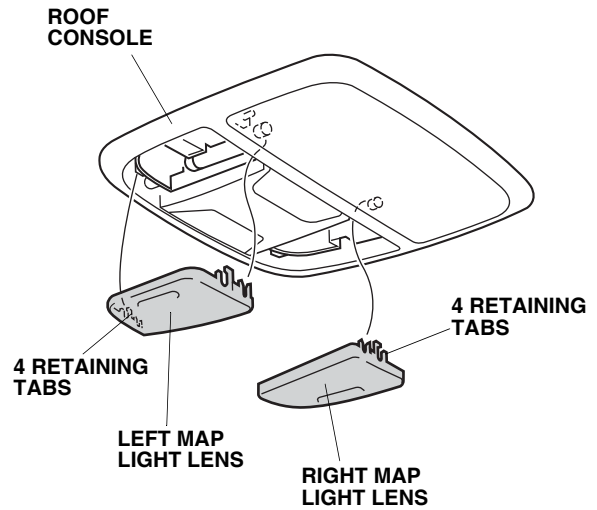

4. Remove the roof console (four bolts and unplug the vehicle connectors).

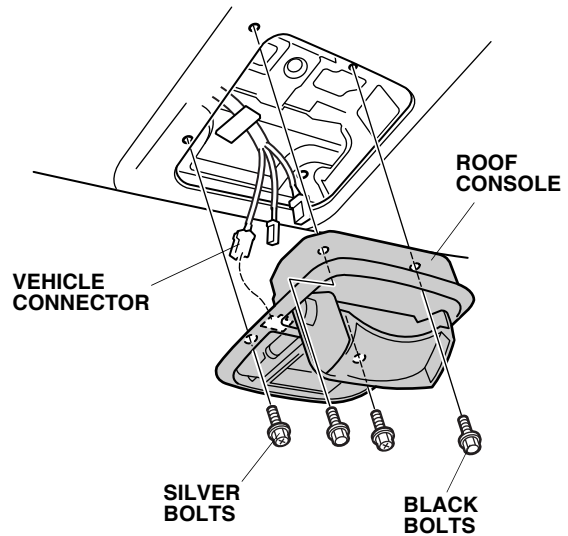

- Remove the cover from the left sunvisor (four retaining tabs).

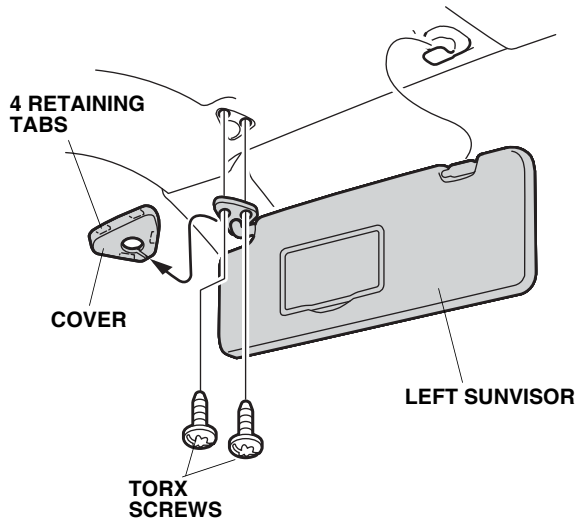

- Remove the two T-25 TORX screws, pull out the left sun visor, and remove the sunvisor.
- Remove the right and left sunvisor holders. Using a flat-tip screwdriver, push in on the tab and rotate the holder.

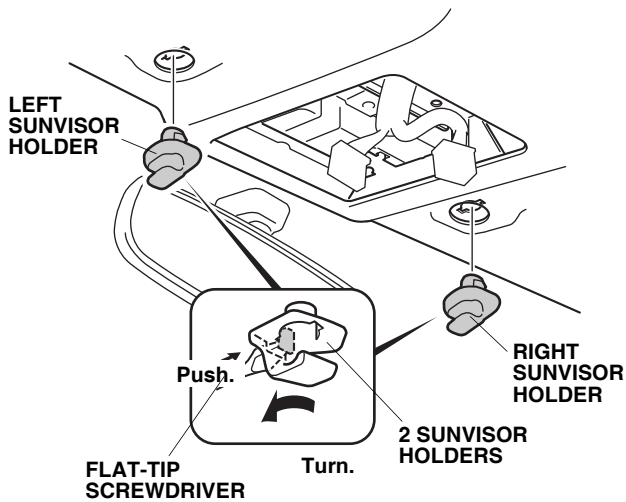

- Remove the cover from the mirror (two retaining tabs). Lift up the mirror while pulling out on the base, and remove the mirror.

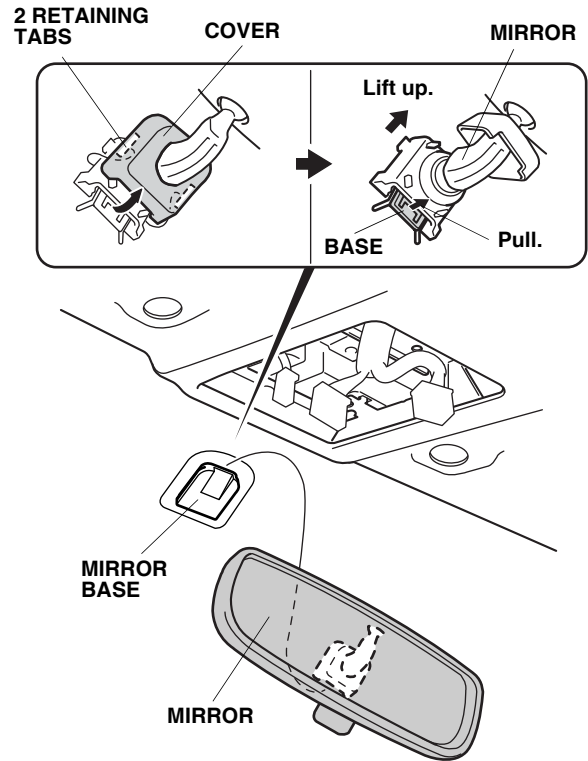

- Using a flat-tip screwdriver, remove the two caps from the left front grab rail.

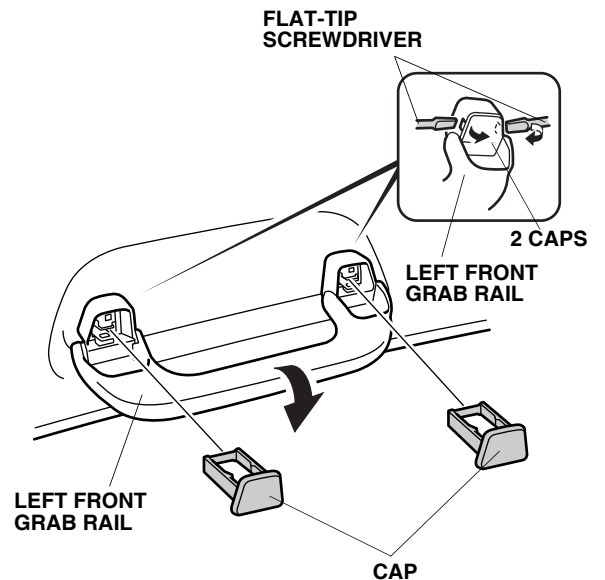

10. Using needle nose pliers, remove the left front grab rail (two clips).

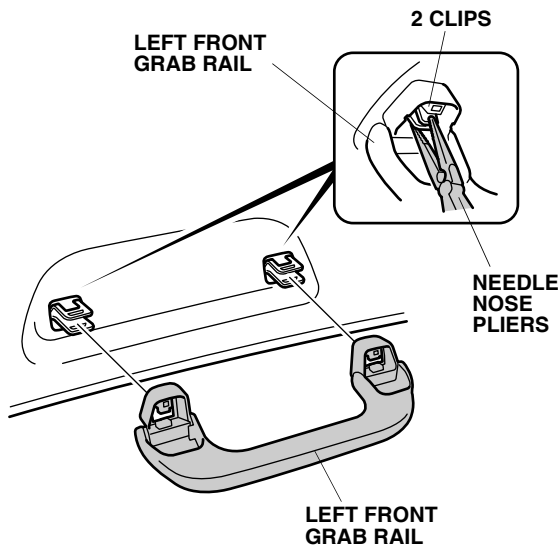

11. Remove the front door opening seal around the A-pillar trim. Using a rubber mallet, strike the top of the A-pillar trim, in the area marked "SIDE CURTAIN AIRBAG", to release the clip. Remove the clip.

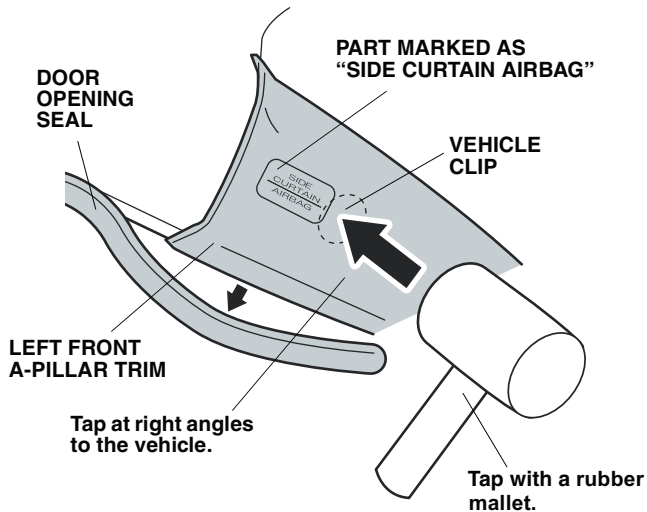
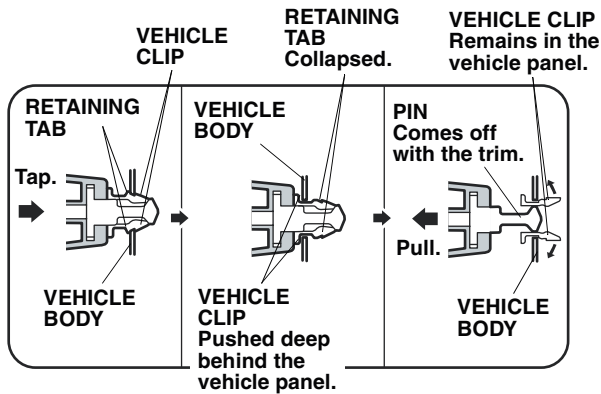

12. Remove the left A-pillar trim (two clips).

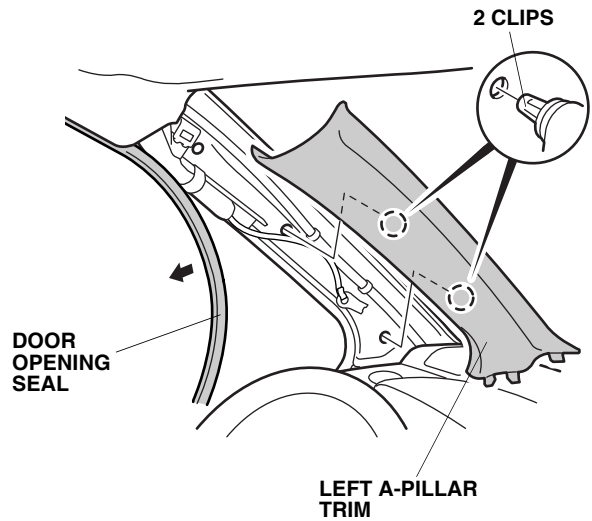

13. Remove the left front door sill trim (three clips).

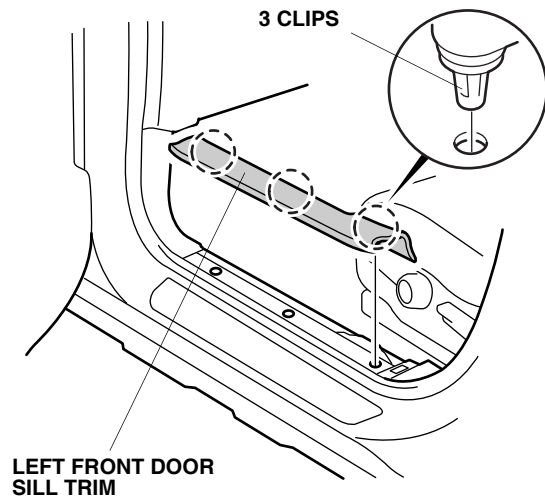

14. Remove the front door opening seal from around the left kick panel. Remove the left kick panel (two clips).

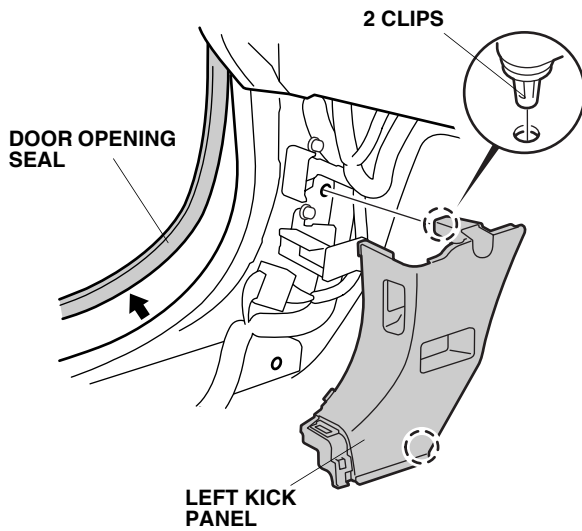

15. Plug the automatic day/night mirror harness 6-pin connector into the empty 6-pin connector opening in the fuse box.

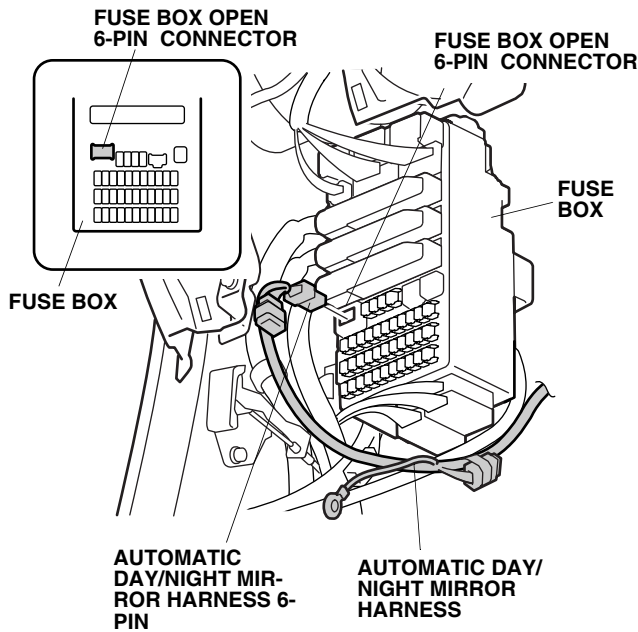

NOTE: If another accessory is already plugged into the 6-pin connector opening of the fuse box, remove the dummy connector from the 6-pin connector taped to the automatic day/night mirror harness. Plug the 6-pin connector from the other accessory harness into the 6-pin connector on the automatic day/night mirror harness and plug the automatic day/night mirror harness into the 6-pin connector opening of the fuse box.

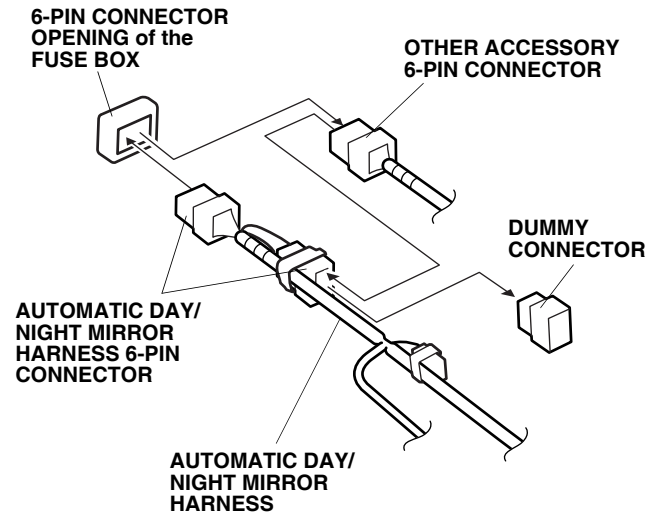

16. Attach a piece of steel wire to the automatic day/night mirror harness, and route it through the left front pillar trim opening.

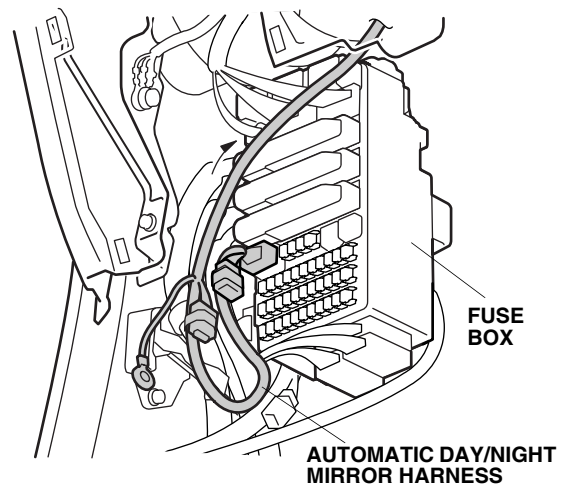
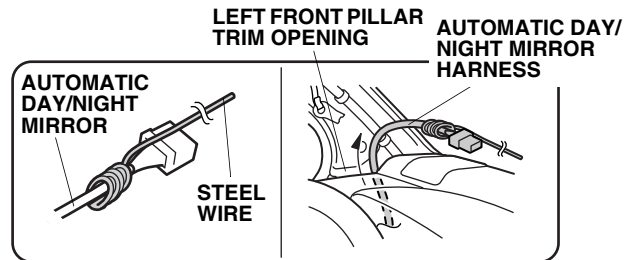

17. Route the automatic day/night mirror harness behind the fuse box.

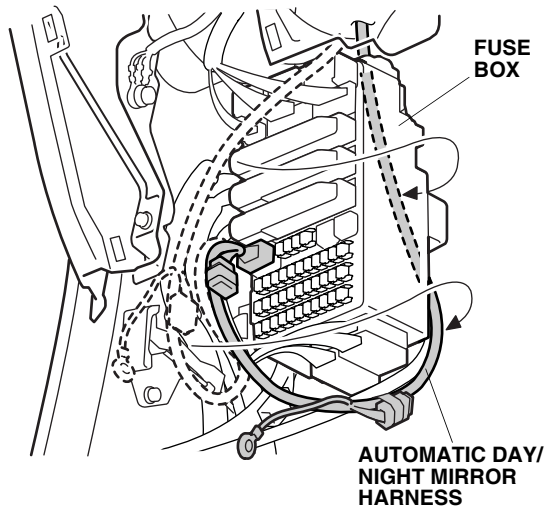

18. Remove the steel wire. Route the automatic day/night mirror harness along the vehicle harness as shown. Loosely secure the day/night mirror harness to the vehicle harness with four wire ties.

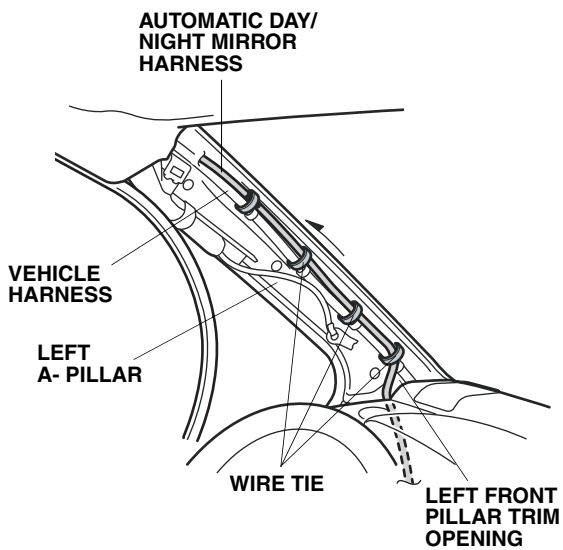

19. Route the automatic day/night mirror harness above the headliner from the left A-pillar to the middle of the vehicle.

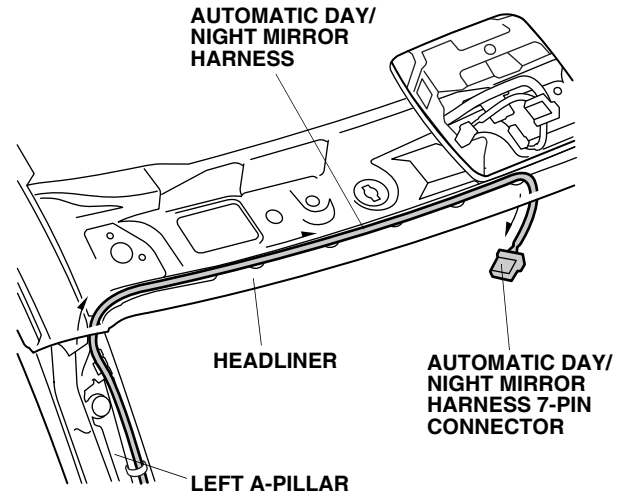

20. Plug the automatic day/night mirror into the day/night mirror 7-pin connector.

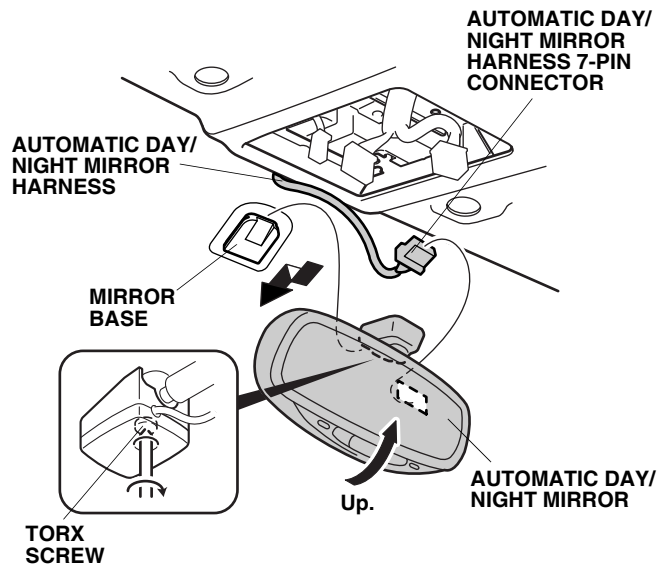

21. Install the day/night mirror on the mirror base, then tighten the T-20 TORX screw installed in the day/night mirror.

22. Using isopropyl alcohol on a shop towel, thoroughly clean the areas where the EPT sealer will attach. Secure the automatic day/night mirror harness to the headliner with three EPT sealers.

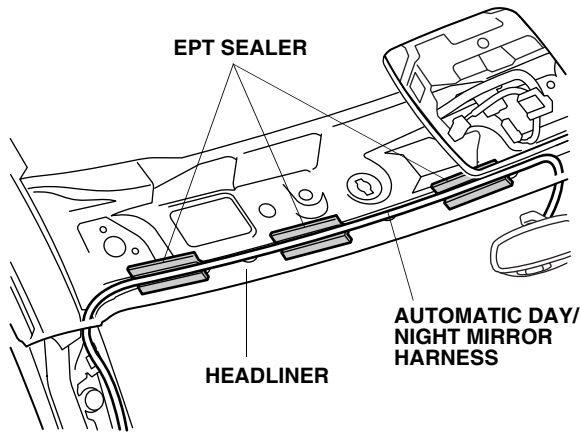

23. Pull the slack in the automatic day/night mirror harness down the A-pillar to the fuse box. Tighten the four wire ties installed in step 18.
24. Secure the automatic day/night mirror harness to the vehicle harness with two wire ties in the areas shown.

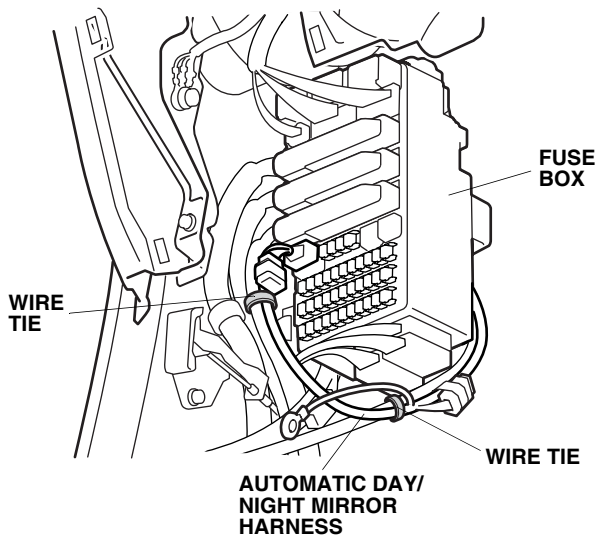

25. Remove the vehicle bolt from the fuel lid opener. Attach the automatic day/night mirror harness ground terminal with the ground bolt supplied.

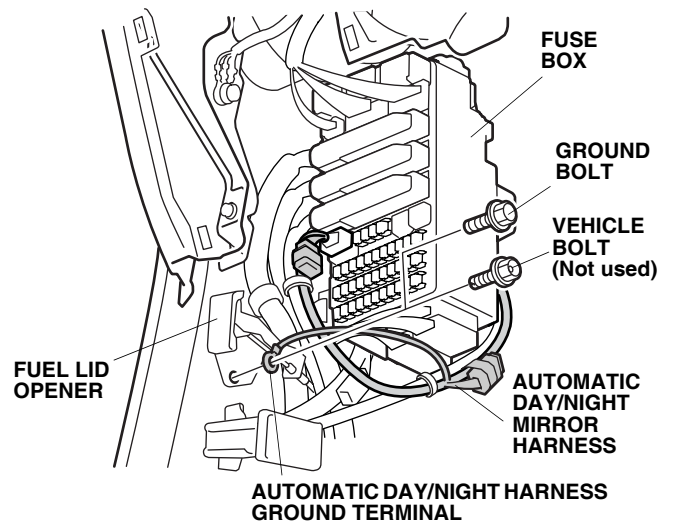

26. Install the harness cover to the automatic day/night mirror and the headliner.

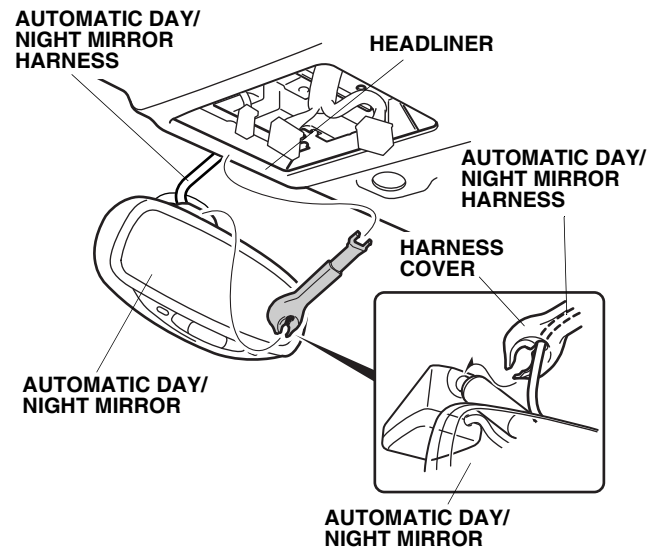



27. Remove and discard the upper vehicle clip from the left A-pillar.

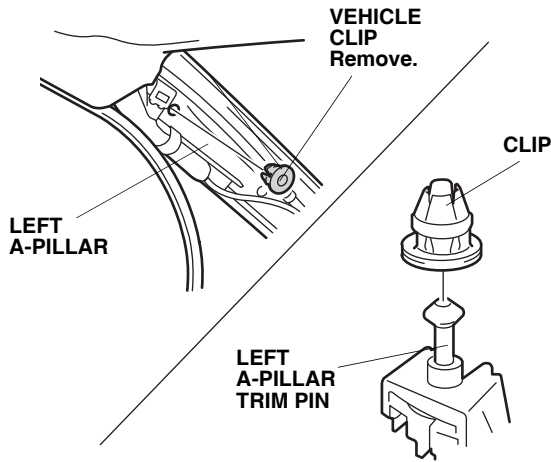

28. Check that the left A-pillar trim and the pin are not damaged, then install the new clip from the kit on the pin.
29. Position the clip at a right angle near the hole in the left A-pillar. Install the clip by lightly pushing the left A-pillar trim at the part marked as "SIDE CURTAIN AIRBAG." Check that the airbag is not pinched by the clip, and be careful not to push the left A-pillar trim excessively.

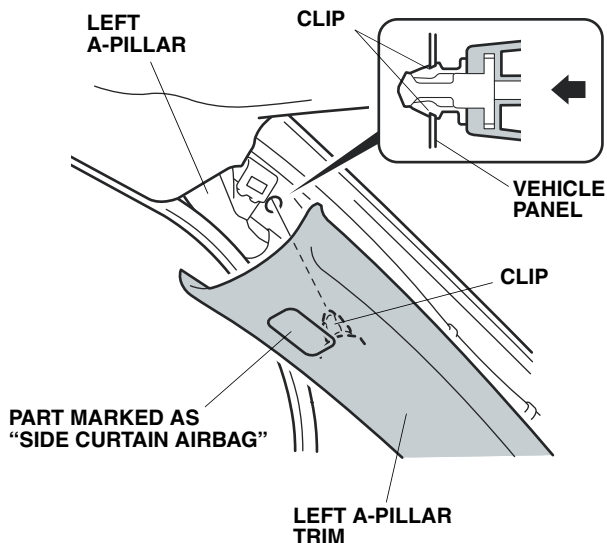

30. Check that all wire harnesses are routed properly and all connectors are plugged in.
31. Reinstall all removed parts.
32. Reconnect the negative cable to the battery.
33. Enter the customer's audio and navigation system (if equipped) anti-theft codes, and reset the XM radio presets.
34. Reset the clock.

NOTE: Check the operation of the automatic day/night mirror according to the operating instructions supplied. Place the operating instructions in the glove box for your customer.