



INSTALLATION INSTRUCTIONS

Accessory
ENGINE BLOCK HEATER
P/N 08T44-SJA-200

Application
2010 RIDGELINE

Publications No.
All 42135

Issue Date
AUG 2009

PARTS LIST

Engine Block Heater Kit

Engine block heater

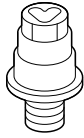

Aluminium washer



Heater harness

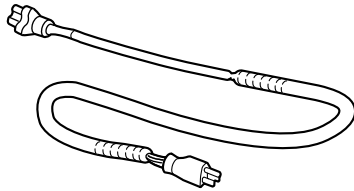

Protective cap

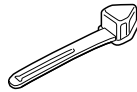

15 Wire ties
(5 Not used)

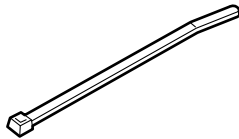

5 Wire ties with clip
(3 Not used)

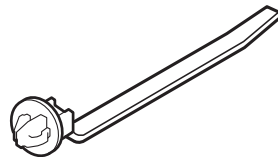

TOOLS AND SUPPLIES REQUIRED

Ratchet

10 mm, 12 mm, 19 mm, and 24 mm Sockets

Torque wrench

Diagonal cutters

Heavy gloves

Drain pan

Tape measure

White marker

Blanket

Coolant (Honda All Season Antifreeze/Coolant Type2)

Fender cover

NOTE: Using a long extension to torque the engine block heater may damage the heater.

INSTALLATION

NOTE:

- Always use Honda All Season Antifreeze/Coolant Type2. Using a non-Honda coolant may cause corrosion, leading to malfunction or failure of the cooling system.
- To avoid burning out the element, do not operate the engine block heater before it is installed in the vehicle and before you add the coolant.

Customer Information: The information in this installation instruction is intended for use only by skilled technicians who have the proper tools, equipment, and training to correctly and safely add equipment to your vehicle. These procedures should not be attempted by “do-it-yourselfers.”

1. Make sure you have the anti-theft code for the radio, then write down the radio station presets.
2. Disconnect the negative cable from the battery.
3. Allow the engine and all cooling system components to cool down.

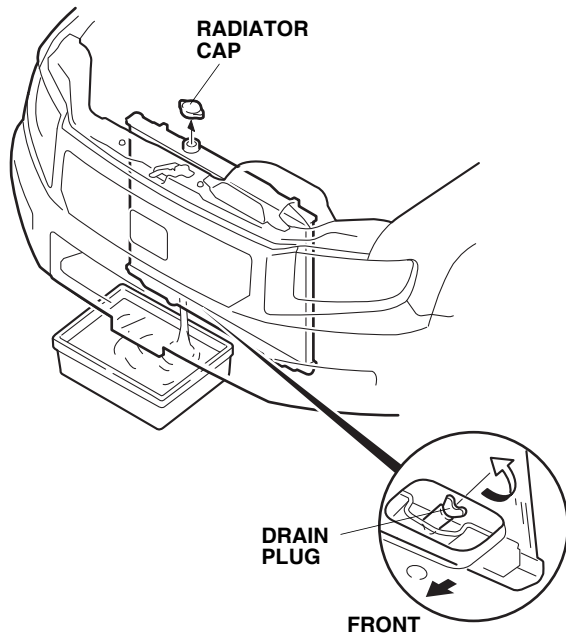

4. Place a clean drain pan under the radiator drain plug, then remove the drain plug from the bottom of the radiator to drain the coolant. Remove the radiator cap to increase the flow.

NOTICE: Radiator coolant will damage paint. Quickly rinse any spilled coolant from painted surfaces.

5. Remove the air duct and the front bulkhead cover (twelve clips).

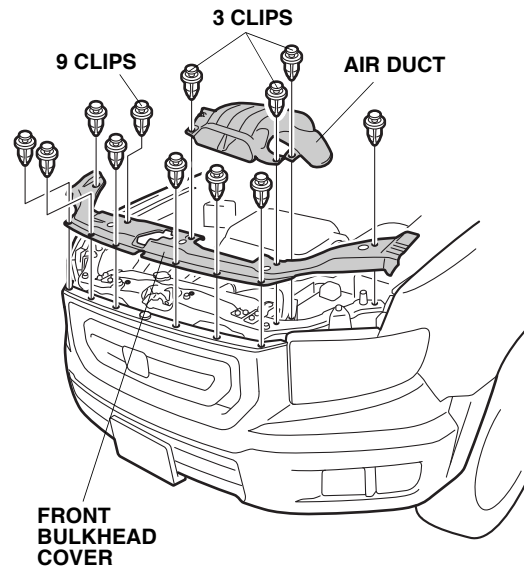

6. Remove the front bumper (one clip, four bolts, two short step bolts and four self-tapping screws). Have an assistant help you when removing and installing the front bumper. If the vehicle is equipped with fog lights, unplug the fog light connectors. Place the front bumper on a blanket after removal.

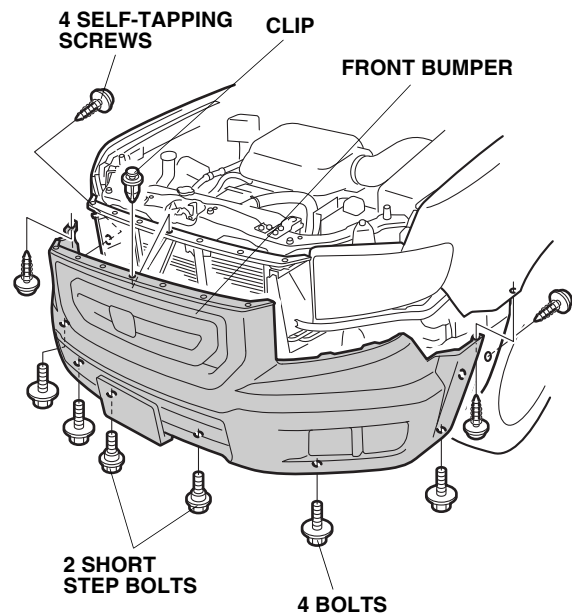

- Get the heater harness. Using a tape measure, install two wire ties with clip to the heater harness at each measurement shown.

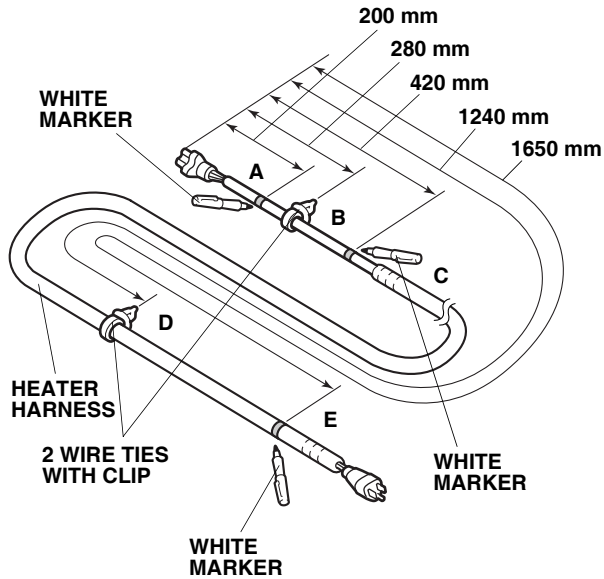

- Using a white marker, mark the heater harness at the measurements shown.
- Remove the vehicle bracket (one vehicle bolt).

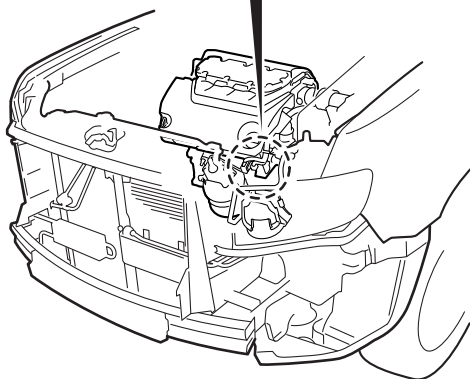
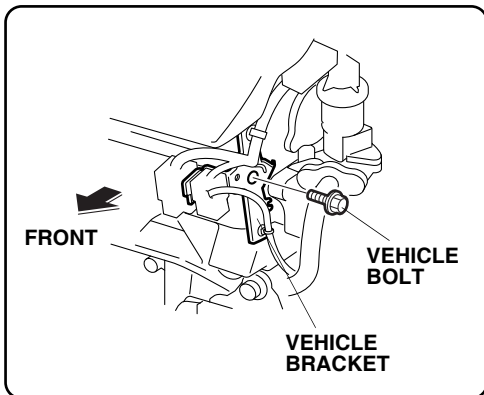

- Locate and remove the engine block drain bolt and washer. Coolant remaining in the engine jackets flows out of the bolt hole when the bolt is removed. (Retain the bolt and washer in case the block heater is removed.)

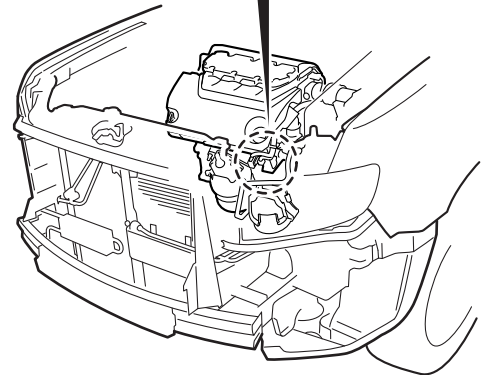
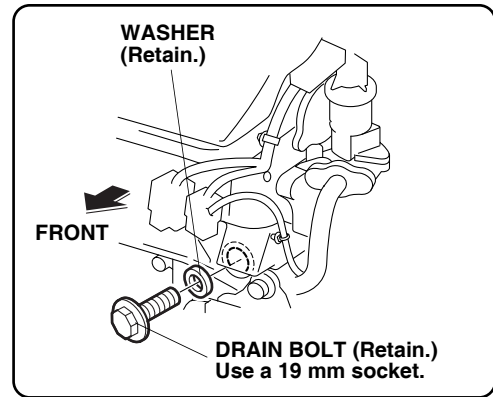

11. Install the engine block heater with aluminum washer into the engine block using a 24 mm socket and a torque wrench. Torque the engine block heater to 60 N·m (44 lbf·ft).

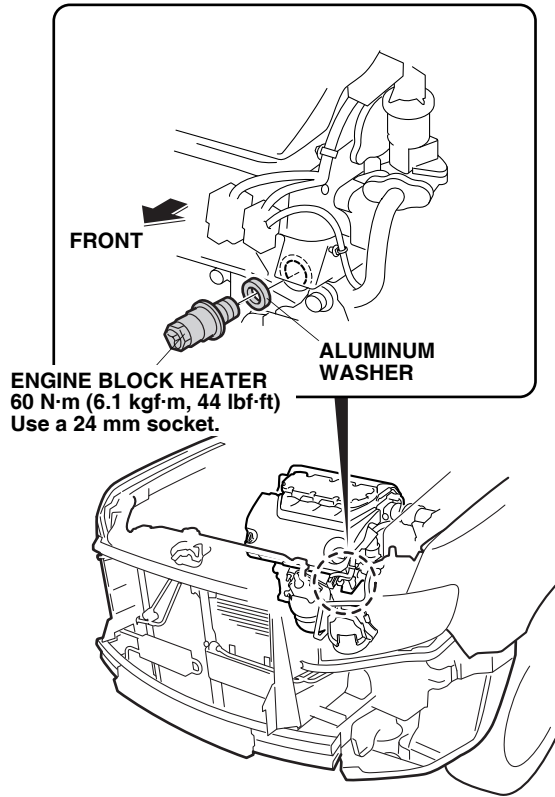

12. Reinstall the vehicle bracket removed in step 9.

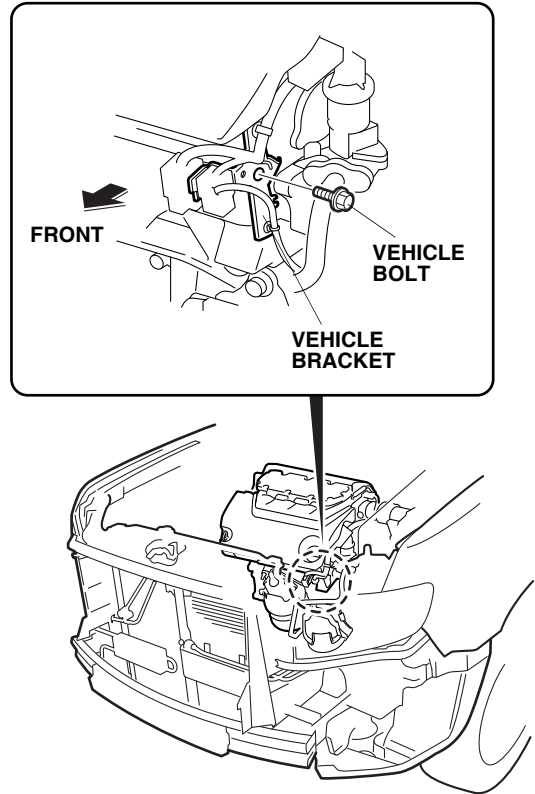

13. Plug the connector end of the heater harness to the engine block heater.

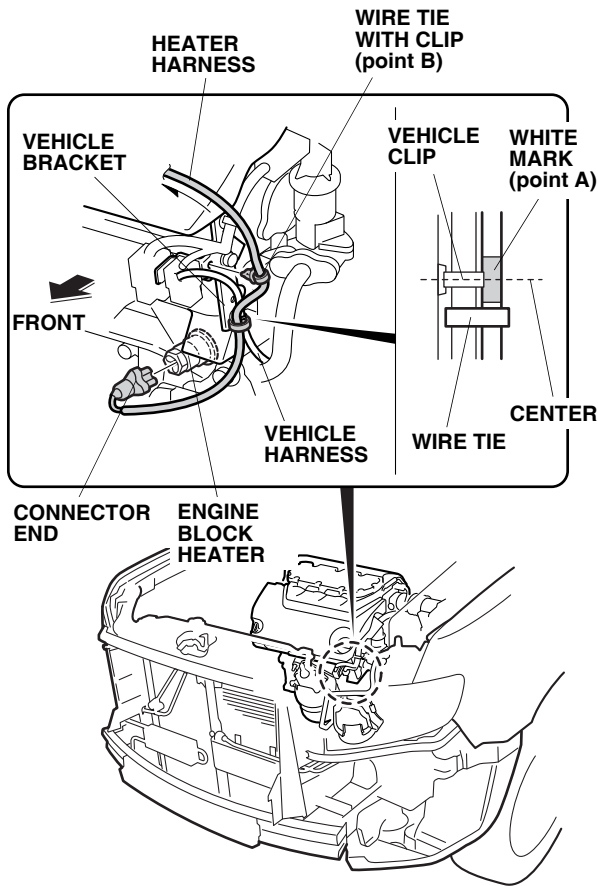

14. Route the heater harness as shown and secure it to the vehicle harness with one wire tie (point A). Secure one wire tie with clip (point B) to the vehicle bracket.

15. Route the heater harness as shown and secure it to the fan shroud rib with one wire tie (point C).

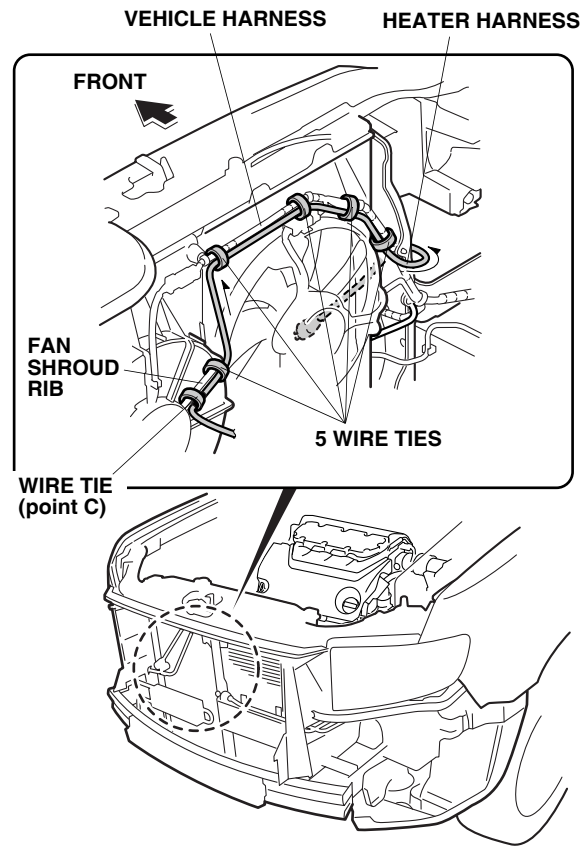

16. Secure the heater harness to the vehicle harness with five wire ties.

- Route the heater harness as shown and secure the wire tie with clip (point D) to the vehicle frame.

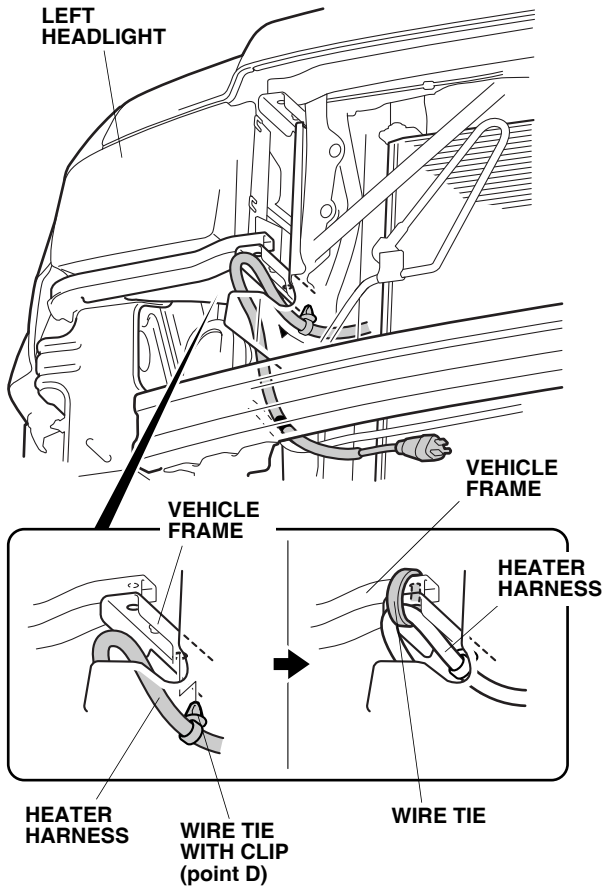

- Secure the heater harness to the vehicle frame with one wire tie.
- Secure it to the vehicle harness with one wire tie (point E).

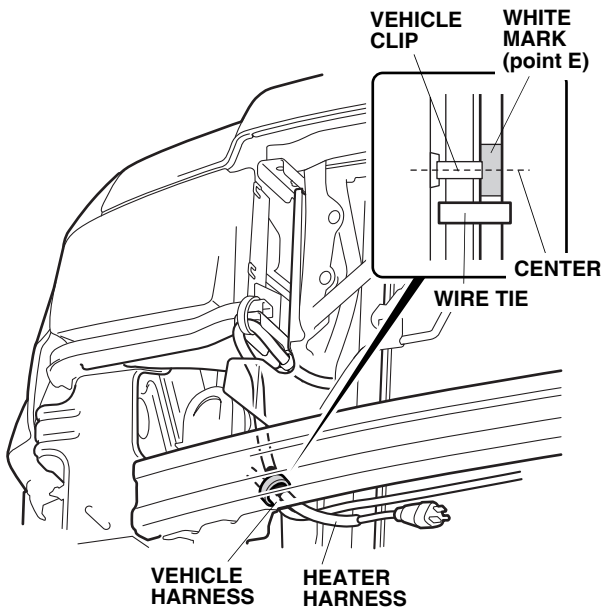

- Loosely install the front bumper in the original position.

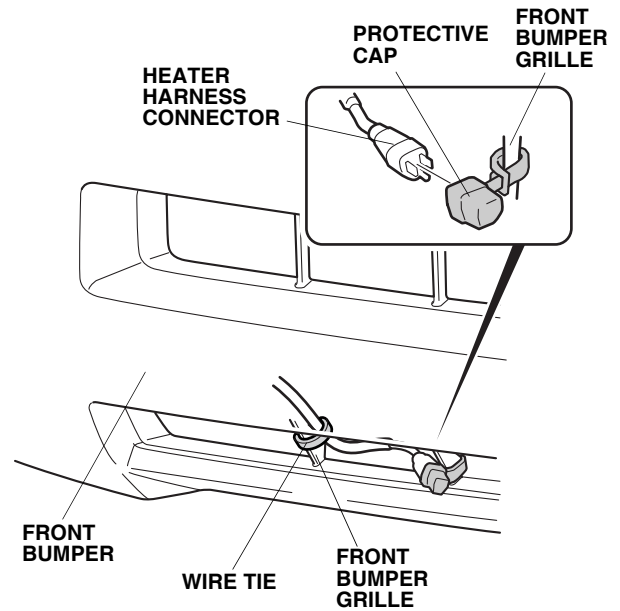

- Route the heater harness inside the front bumper grille and secure it with one wire tie.
- Attach the protective cap to the front bumper grille, and plug the heater harness connector into the protective cap.
- Reinstall all removed parts.
- Reinstall the radiator drain plug.
- Fill the cooling system with the recommended coolant. Follow the instructions described in the service manual to fill and bleed the cooling system.
- Check the coolant reservoir for correct level and check the cooling system for signs of leakage. Repair as necessary.
- Check that the heater harness is routed properly and all connectors are plugged in.
- Put the drain bolt (removed in step 10) in the glove box.
- Reconnect the negative cable to the battery.
- Enter the radio anti-theft code, and reset the radio station presets.
- Reset the clock.