

PARTS LIST

Right running board

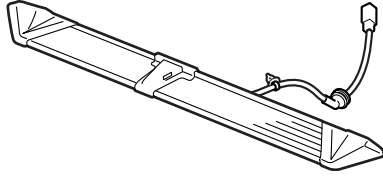

Left running board

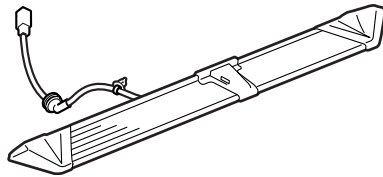

Right bracket A

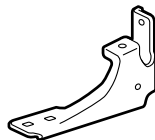

Left bracket A

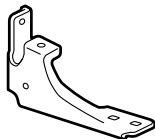

2 Right brackets B

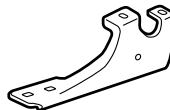

2 Left brackets B

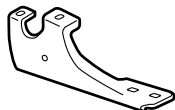

12 Flange bolts

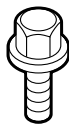

12 Flange nuts



5 EPT sealers

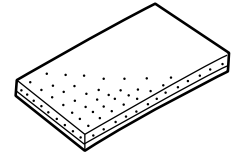

5 Wire ties

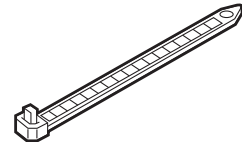

2 Rivet Nuts

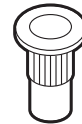
**TOOLS AND SUPPLIES REQUIRED**

Torque wrench

Socket

Scissors

Shop towel

Isopropyl alcohol

Rivet nut tool

T/N LEML722M8

27 mm Wrench

Hex wrench

Combination wrench

Diagonal cutters

Illustration of the Running Boards Kit Installed on the Vehicle

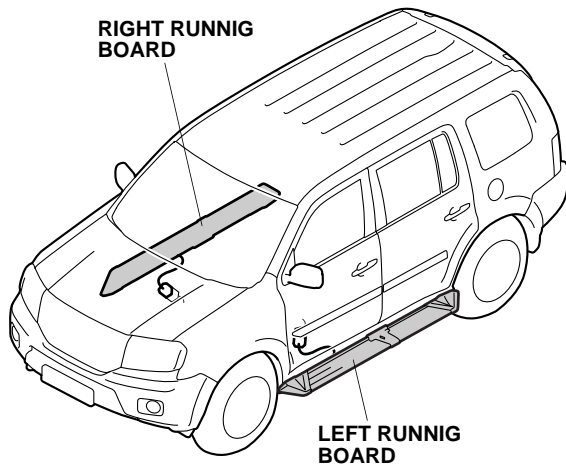

INSTALLATION

Customer Information: The information in this installation instruction is intended for use only by skilled technicians who have the proper tools, equipment, and training to correctly and safely add equipment to your vehicle. These procedures should not be attempted by "do-it-yourselfers."

NOTE:

- Thoroughly clean the bottom of the body from the rear of the front wheels up to the front of the rear wheels.
 - Be careful not to damage the body paint finish. To prevent damage, place a blanket under the running board during the installation.
 - These instructions show the left side running board being installed; the same procedure applies to installing the right side running board.
1. Make sure you have anti-theft code for the radio, then write down the radio station presets.
 2. Disconnect the negative cable from the battery.

Removing the Vehicle Parts

3. Remove the left front side step trim (four clips).

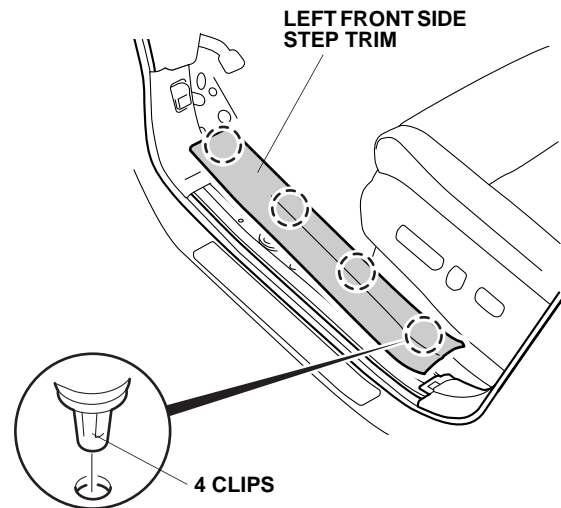

4. Peel the weatherstrip, and remove the left kick panel (two clips).

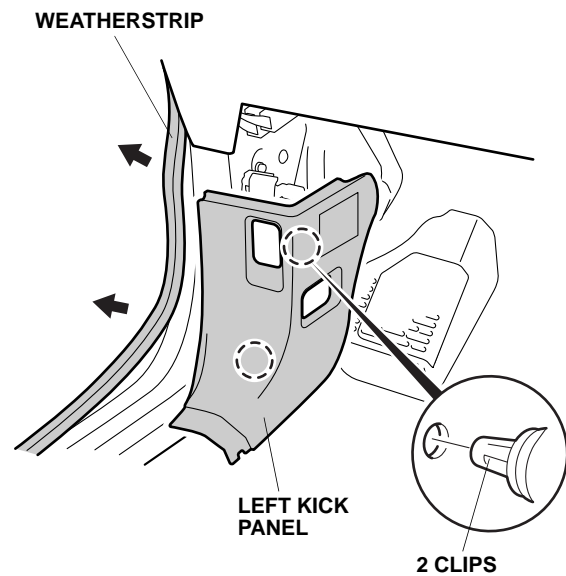

5. Remove the foot rest cover (seven hooks).

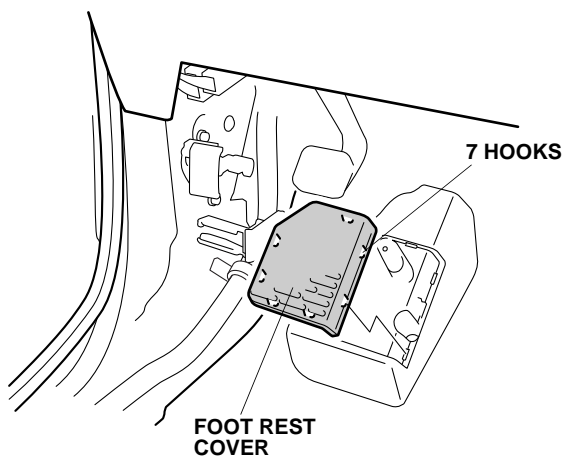

6. Remove the foot rest (two flange nuts).

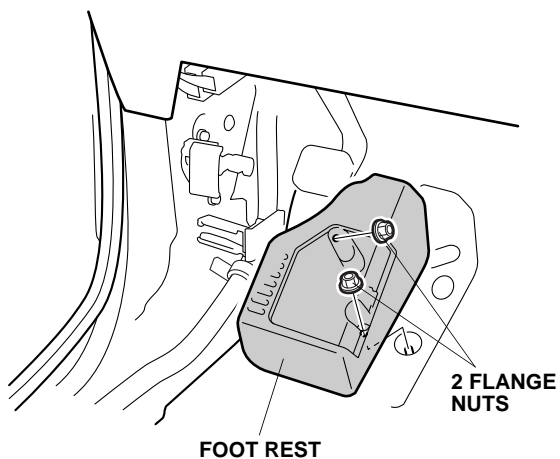

7. Remove the right front side step trim (four clips).

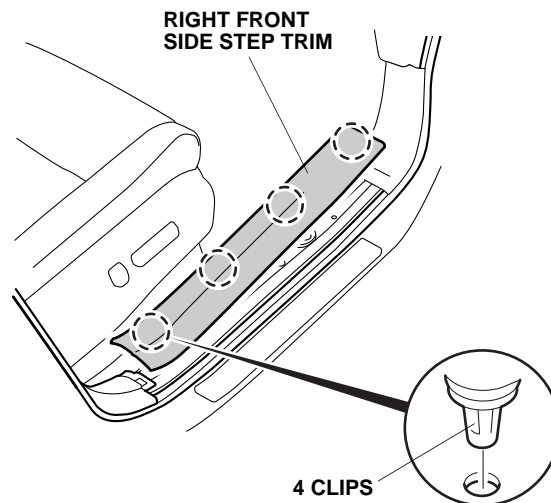

8. Peel the weatherstrip, and remove the right kick panel (two clips).

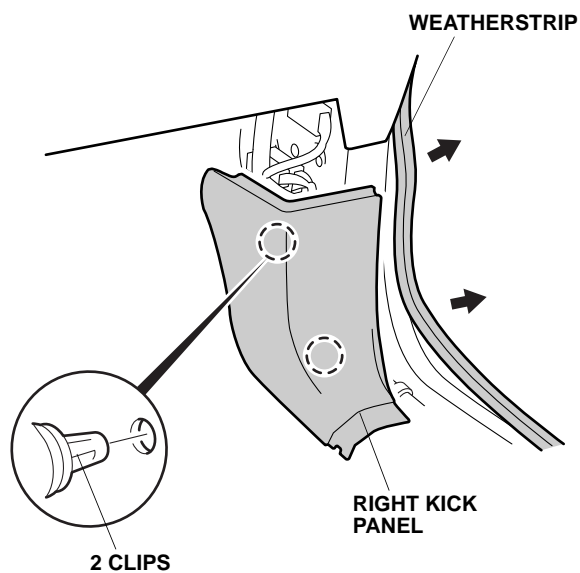

Installing the Running Board

9. Install the rivet nut to the vehicle frame as shown.

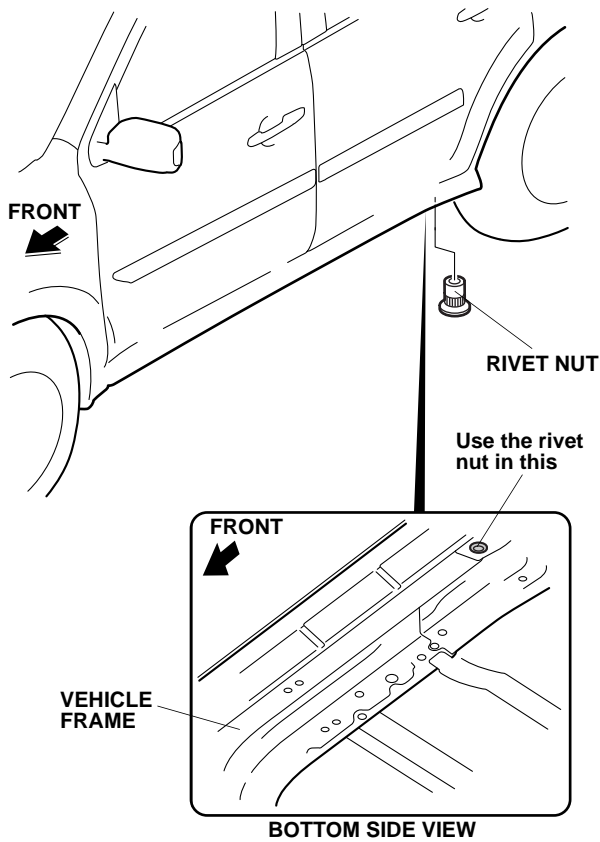

- Screw the rivet nut onto the mandrel of the rivet nut tool as shown.

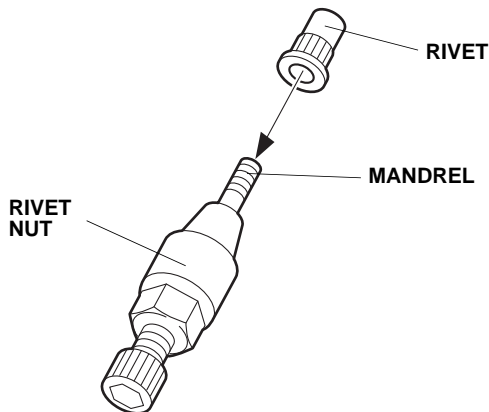

- Insert the rivet nut into the hole in the vehicle frame and install the hex wrench on the rivet nut tool.

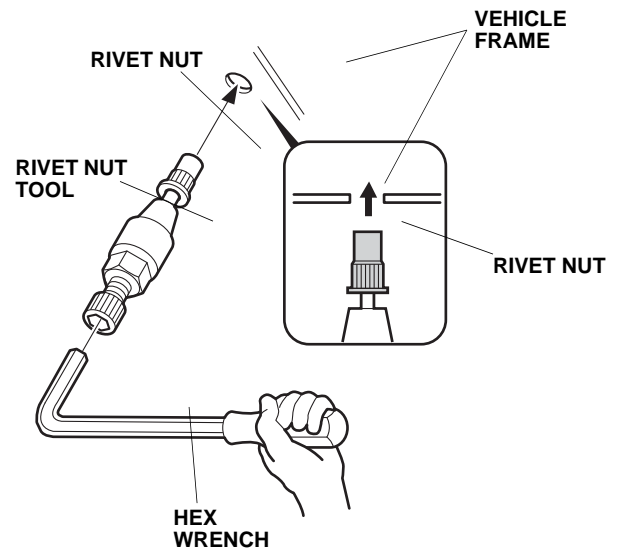

- Holding the rivet nut tool with the hex wrench, turn the 27 mm wrench clockwise and install the rivet nut on the vehicle frame.
- Remove the rivet nut tool from the rivet nut by turning the hex wrench counterclockwise.

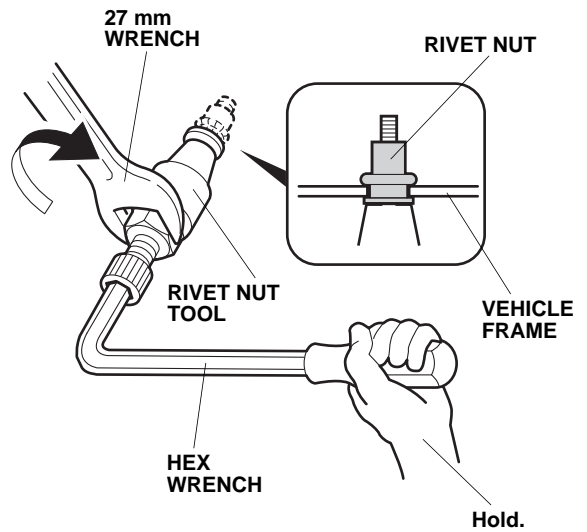

10. Position the left bracket A at the respective installation positions of the vehicle frame. Install the left bracket A on the vehicle frame with the two flange bolts. Do not tighten the flange bolts yet. Make sure the flange bolts are installed in the correct positions.

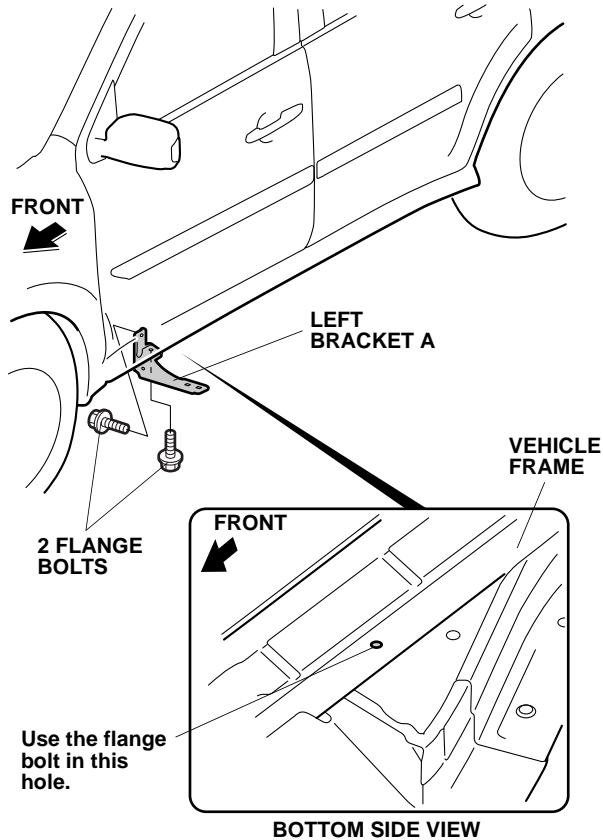

11. Position the two left brackets B at the respective installation positions of the vehicle frame. Install the two left brackets B on the vehicle frame with the two flange bolts for each. Do not tighten the flange bolts yet. Make sure the flange bolts are installed in the correct positions.

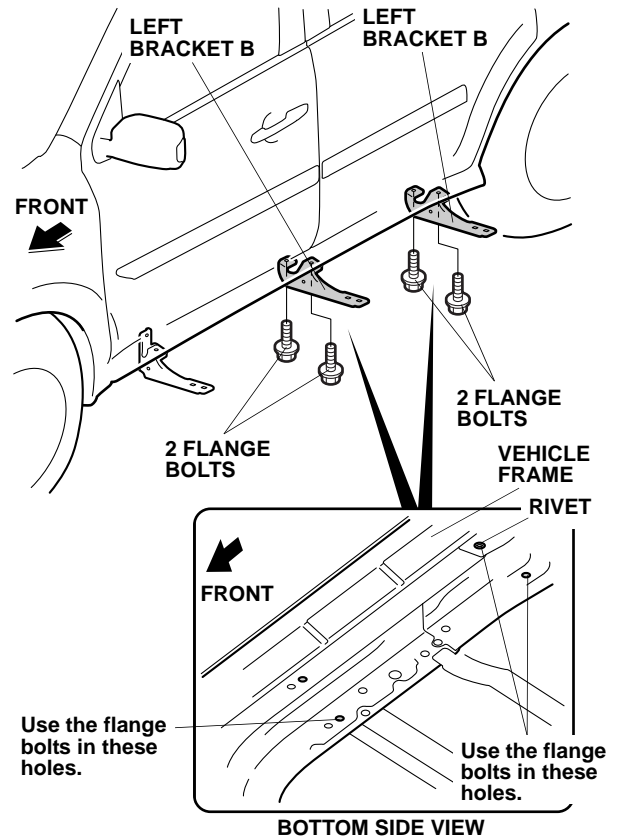

- Position the left running board on the left bracket A and the two left brackets B. Install the left running board with the six flange nuts. Do not tighten the flange nuts yet.

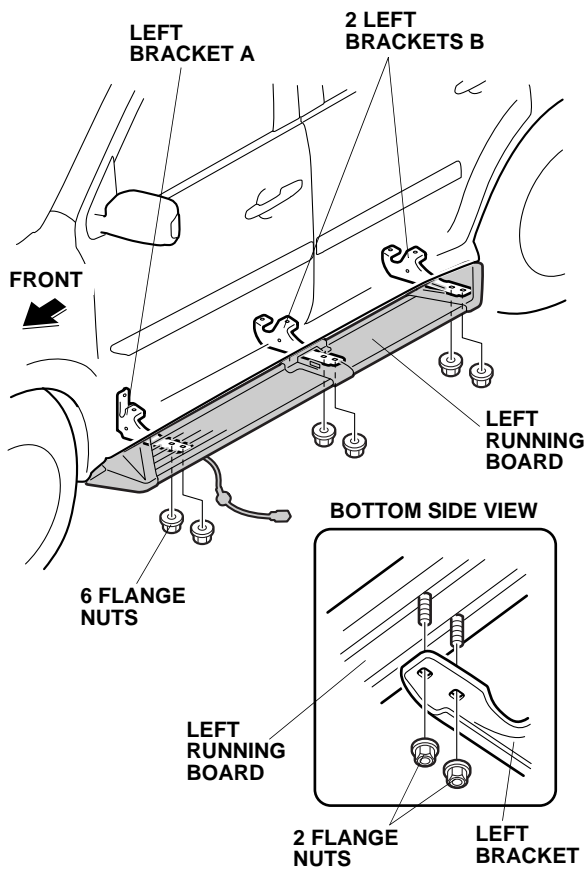

- Align the front left running board with the left front door edge as shown.

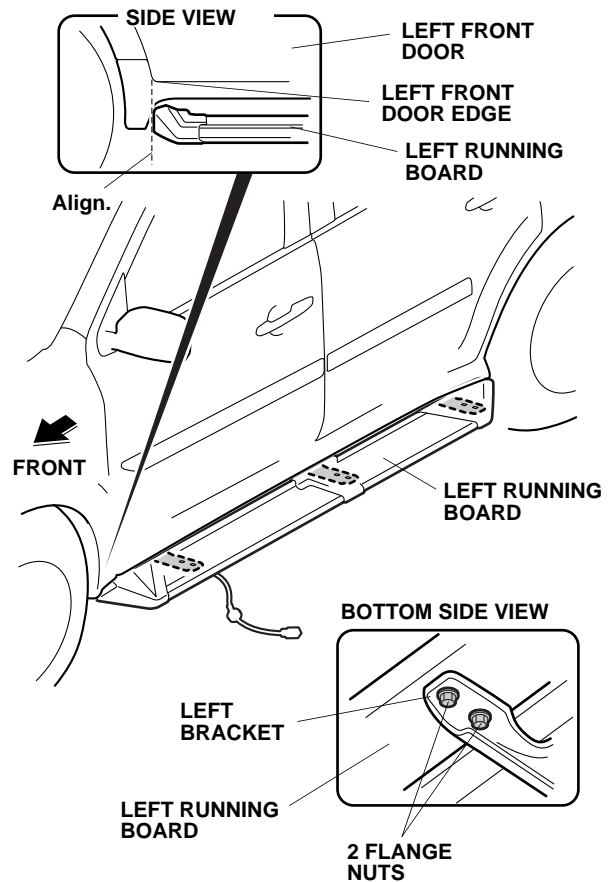

- Tighten the six flange nuts that were loosely installed in step 12. Torque the flange nuts to 27 N·m (19 lbf·ft).
- Tighten the six flange bolts that were loosely installed in step 10 and step 11. Torque the flange bolts to 27 N·m (19 lbf·ft).
- Repeat steps 9 through 15 to install the running board on the right side of the vehicle.

Routing the Left Running Board Light Harness

17. Remove the clip on the driver's side, and pull away the floor carpet from the area shown.

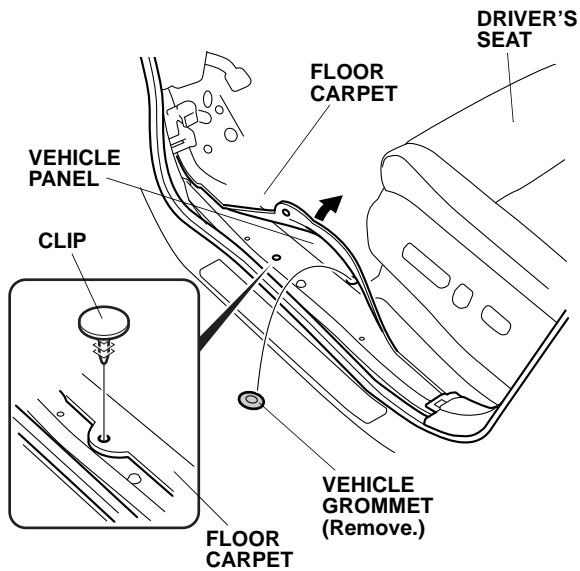

18. Remove the vehicle grommet of the vehicle panel.

19. Route the left running board light harness into the grommet hole on the vehicle, and install the grommet in the vehicle panel.

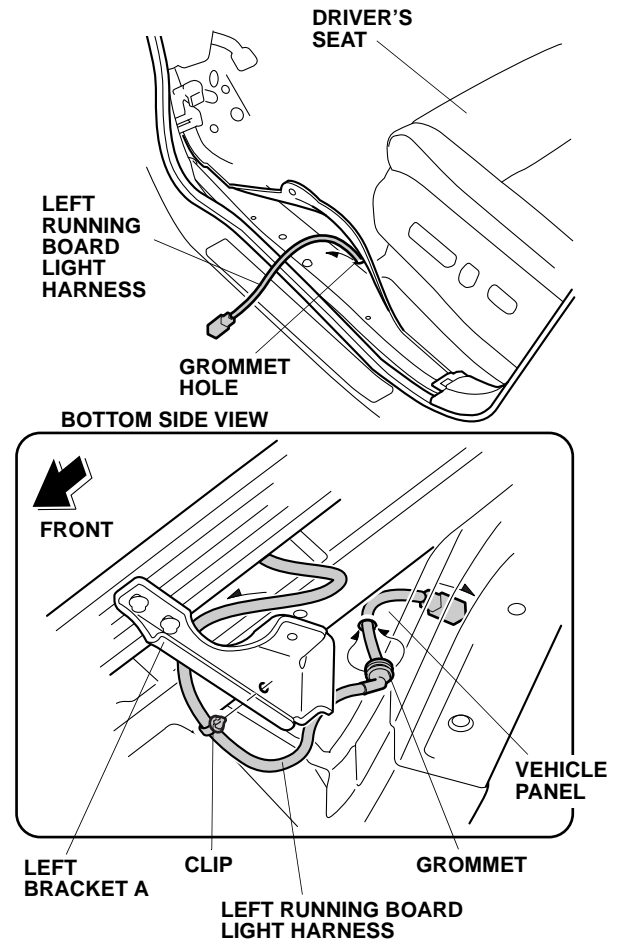

20. Install the clip to the left bracket A.

21. Route the left running board light harness in the vehicle as shown.

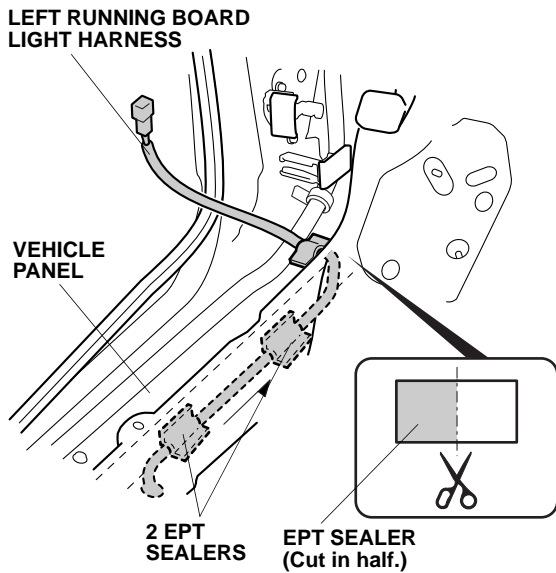

22. Using isopropyl alcohol on a shop towel, clean the areas where the EPT sealers will attach. Secure the left running board light harness to the vehicle panel with two EPT sealers.
23. Cut a EPT sealer in half, and secure the left running board light harness to the vehicle panel with one half EPT sealer.
24. Locate and remove the two blue tapes to free the vehicle 2-pin connector.

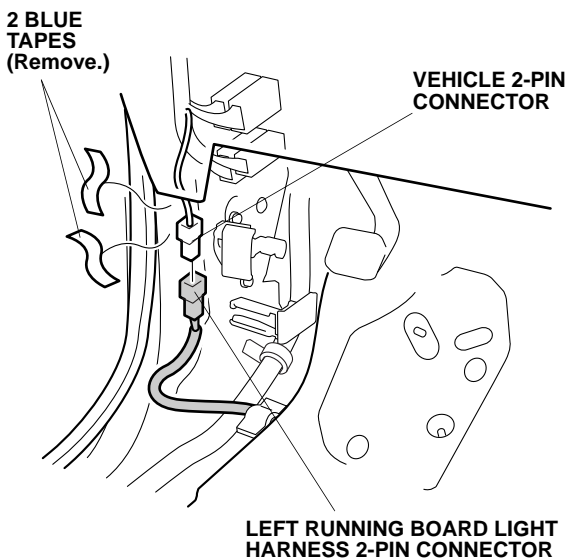

25. Plug the left running board light harness 2-pin connector into the vehicle 2-pin connector.

26. Secure the left running board light harness to the vehicle harness with the three wire ties.

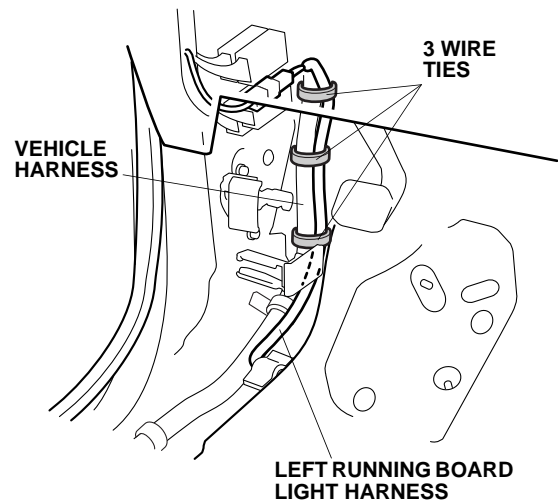

Routing the Right Running Board Light Harness

27. Remove the clip on the passenger's side, and pull away the floor carpet from the area shown.

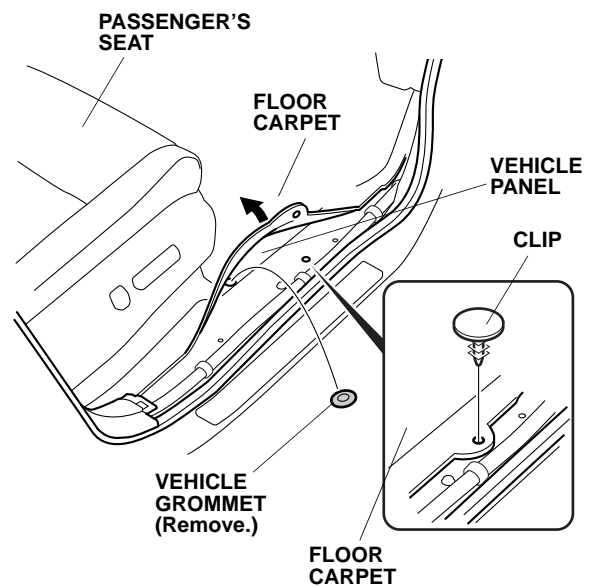

28. Remove the vehicle grommet from the vehicle panel.

29. Route the right running board light harness into the grommet hole of the vehicle, and install the grommet in the vehicle panel.

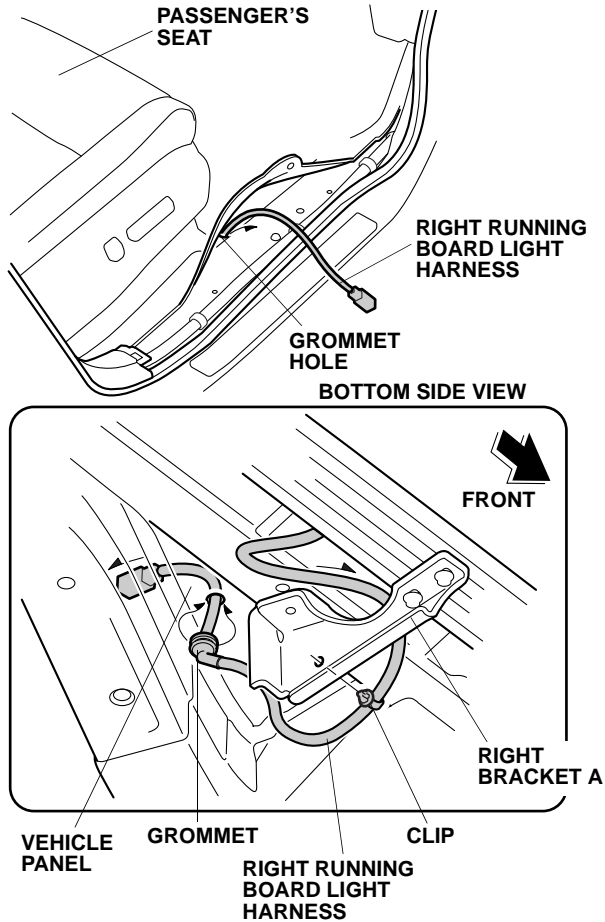

30. Install the clip to the right bracket A.

31. Route the right running board light harness in the vehicle as shown.

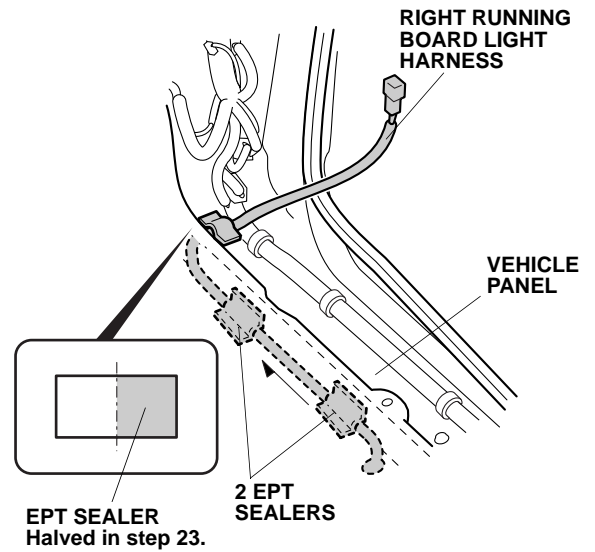

32. Using isopropyl alcohol on a shop towel, clean the areas where the EPT sealers will attach. Secure the left running board light harness to the vehicle panel with two EPT sealers.
33. Secure the right running board light harness to the vehicle panel with one half EPT sealer you made in step 23.
34. Locate and remove the blue tape to free the vehicle 2-pin connector.

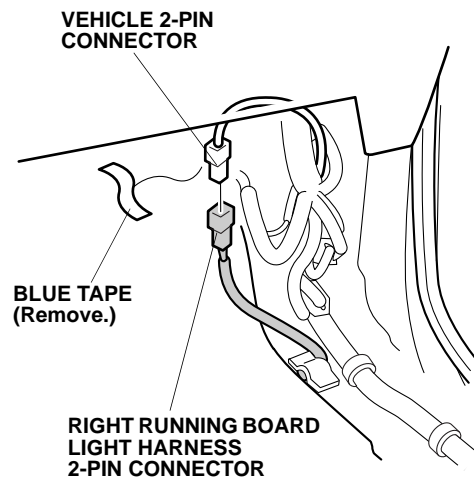

35. Plug the right running board light harness 2-pin connector into the vehicle 2-pin connector.

36. Secure the right running board light harness to the vehicle harness with two wire ties.

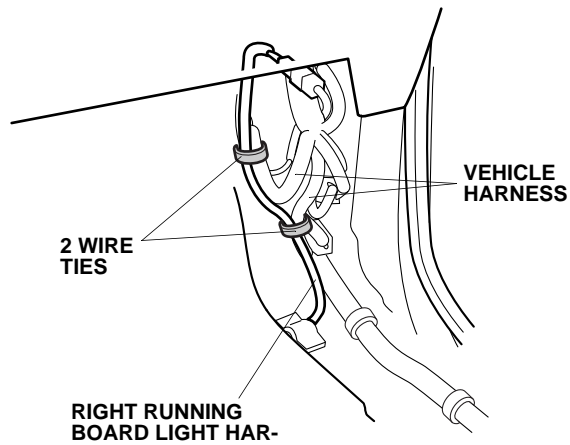

37. Check that all wire harnesses are routed properly and all connectors are plugged in.
38. Reinstall all removed parts.
39. Reconnect the negative cable to the battery.
40. Enter the customer's radio anti-theft code, and reset the radio station presets.
41. Reset the clock.

Check the Operation of the Running Board with Light

- Light on the running board will turn on when the door is opened.
- Light on the running board will turn off after closing the door for a period of time.
- Light on the running board will turn on when the key on the driver's side is unlocked.