

PARTS LIST

Right fog light

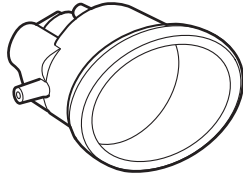

Left fog light

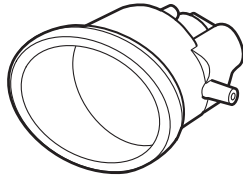

Right fog light bracket

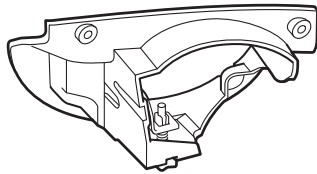

Left fog light bracket

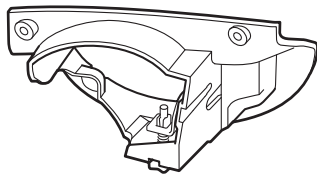

2 Washer-screws



4 Stepped screws

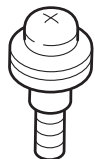

8 Self-tapping screws



Switch harness

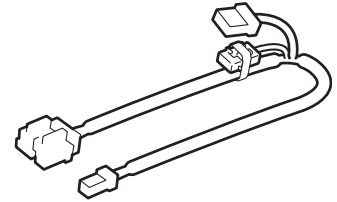

Fog light harness

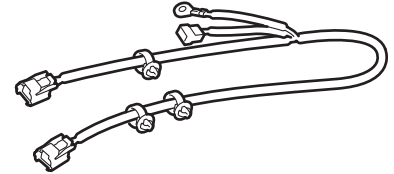

Right trim

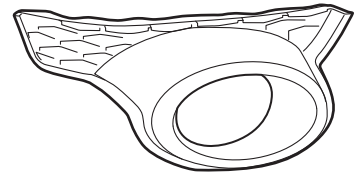

Left trim

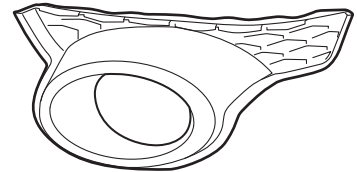

Combination switch

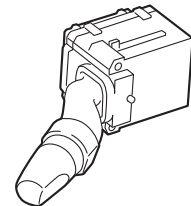

Relay

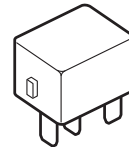

Fuse label

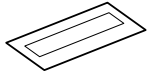

Relay bracket

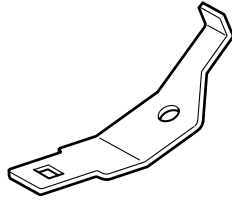

Washer-bolt

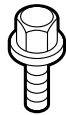

Flange nut



18 Wire ties
(2 Not used)

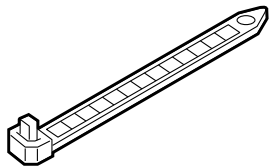

2 Wire ties with clip

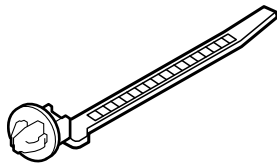

Clip

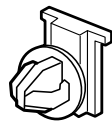

TOOLS AND SUPPLIES REQUIRED

Phillips screwdriver

Flat-tip screwdriver

Ratchet

8 mm and 10 mm Sockets

File

Utility knife

Clip remover

Eye protection (face shield, safety goggle, etc.)

Drill

3 mm Drill bit

Hack saw

Diagonal cutters

25 mm Hole saw

Masking tape

Pushpin

Isopropyl alcohol

Shop towel

Blanket

Illustration of the Fog Lights Installed on the Vehicle

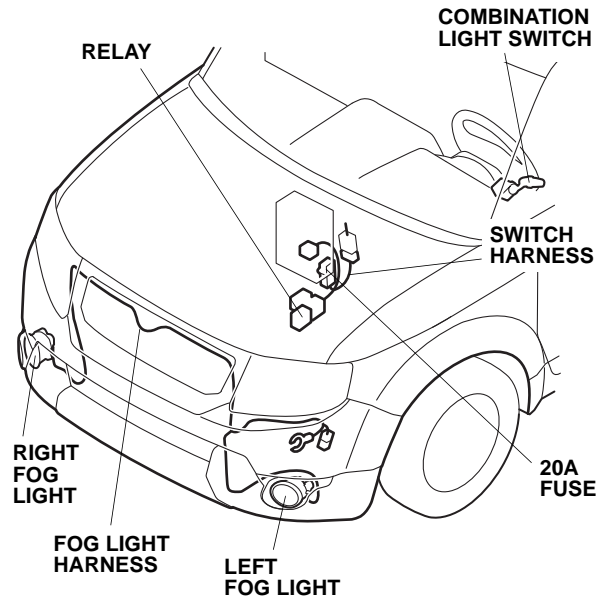

INSTALLATION

Customer Information: The information in this installation instruction is intended for use only by skilled technicians who have the proper tools, equipment, and training to correctly and safely add equipment to your vehicle. These procedures should not be attempted by "do-it-yourselfers."

NOTE: These installation instruction show the left fog light being installed. The same procedure applies to installing the right fog light.

1. Make sure you have the anti-theft code for the radio, then write down the frequencies for the preset buttons.
2. Disconnect the negative cable from the battery.

Installing the Fog Lights

3. Remove the radiator cover (five clips).

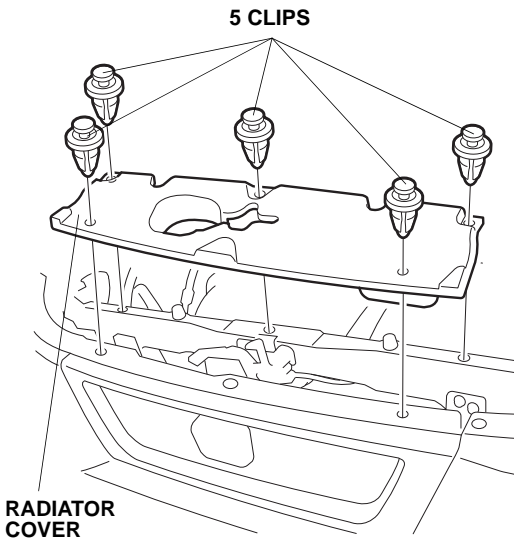

4. With the help of an assistant, remove the front bumper (five clips, four stepped bolts, and four self-tapping screws). Place the front bumper on a blanket to prevent damage.

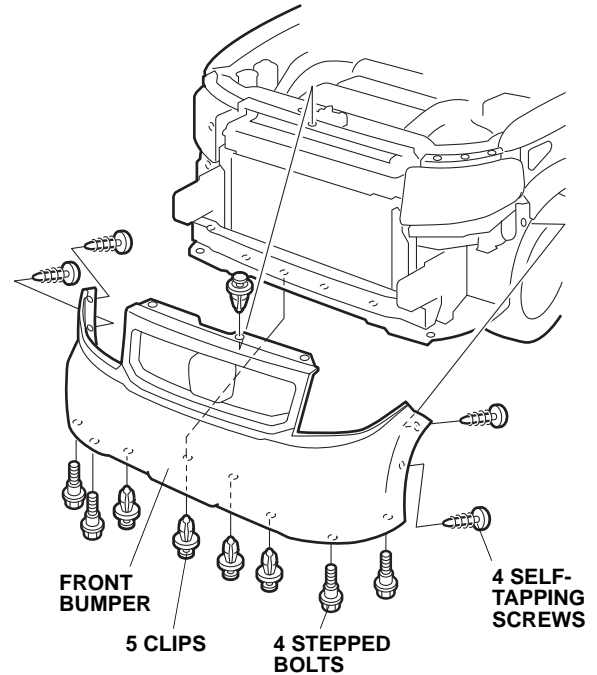

5. On the inside of the bumper, locate the 10 preset marks. Using a pushpin, pierce the center of each preset mark all the way through the bumper.

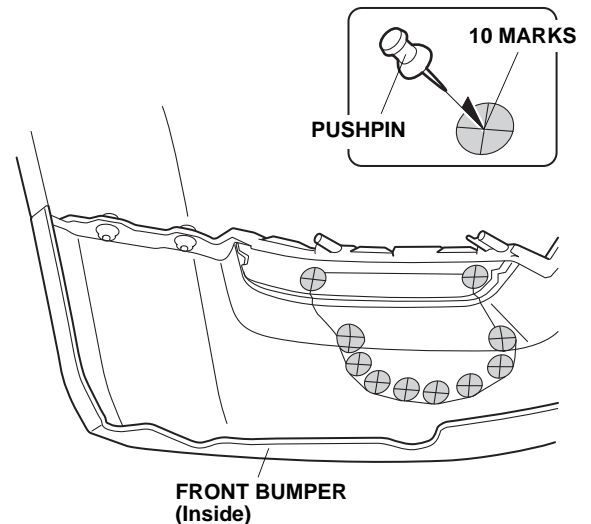

- Attach masking tape to the outer surface of the bumper in the areas shown.

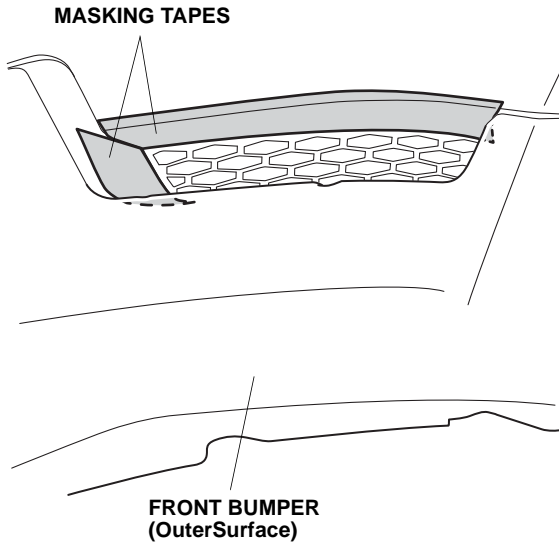

- On the inside of the bumper, drill the two upper pierced marks to 25 mm. While wearing eye protection, first drill with a 3 mm drill bit, and then finish with a 25 mm hole saw.

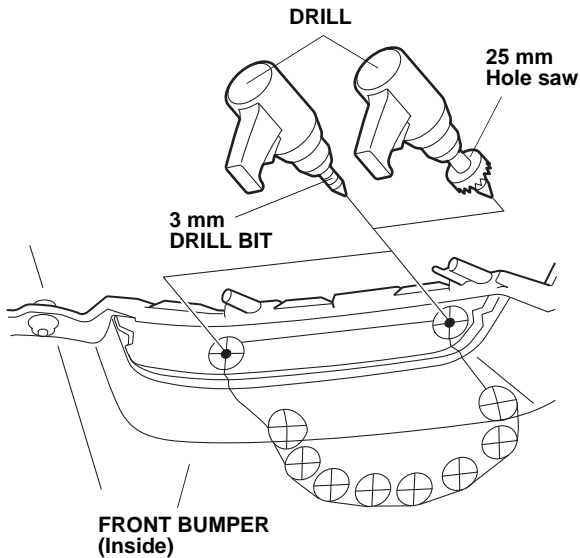

- On the outer surface of the bumper, drill the remaining eight pierced marks to 25 mm. While wearing eye protection, drill with a 3 mm drill bit, and then finish with a 25 mm hole saw.

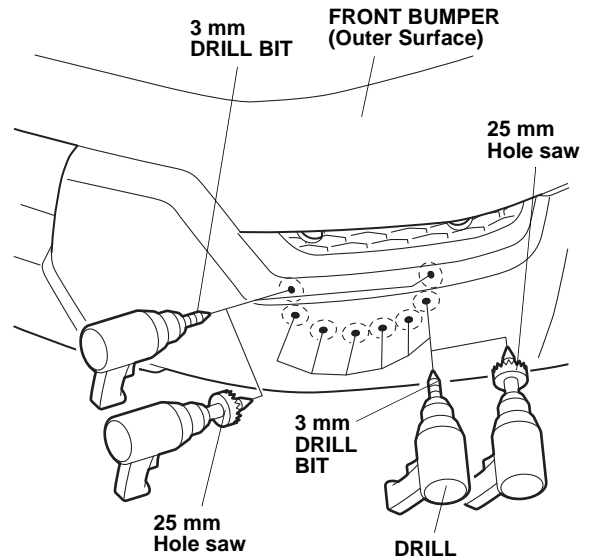

- Using a hacksaw, cut out the front bumper.

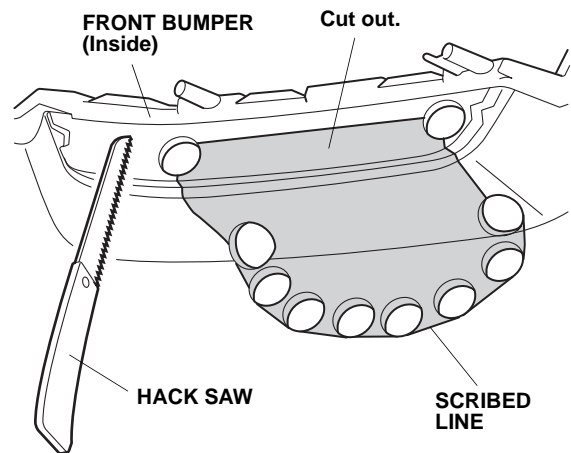

- Remove any burrs from the cut edge.
- Repeat steps 5 thru 10 to pierce and cut the other side.

12. Install the left fog light bracket to the left fog light using two stepped screws and one washer screw.

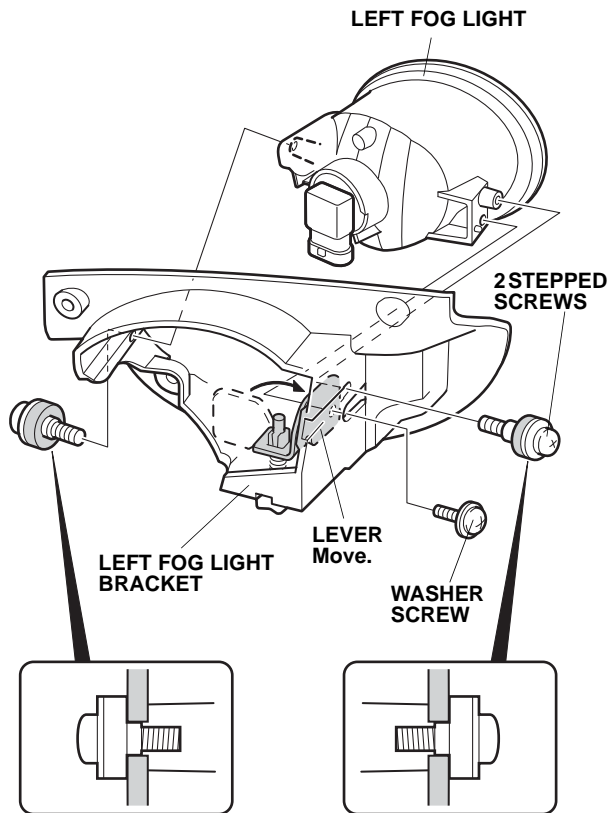

13. Position the left cover on the front bumper.

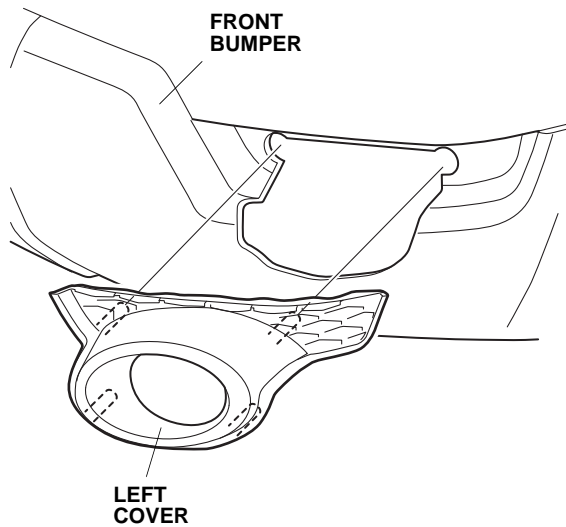

14. Install the left fog light bracket to the front bumper using four self-tapping screws. Thread the self-tapping screws into the left trim.

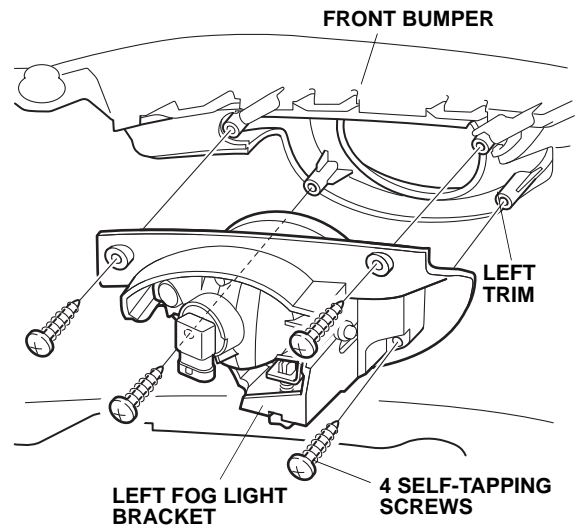

15. Repeat steps 12 thru 14 to install the right fog light and bracket.

Routing the Fog Light Harness

16. Starting under the left headlight, route the fog light harness 1-pin connector and ground terminal through the hole in the front bulkhead.

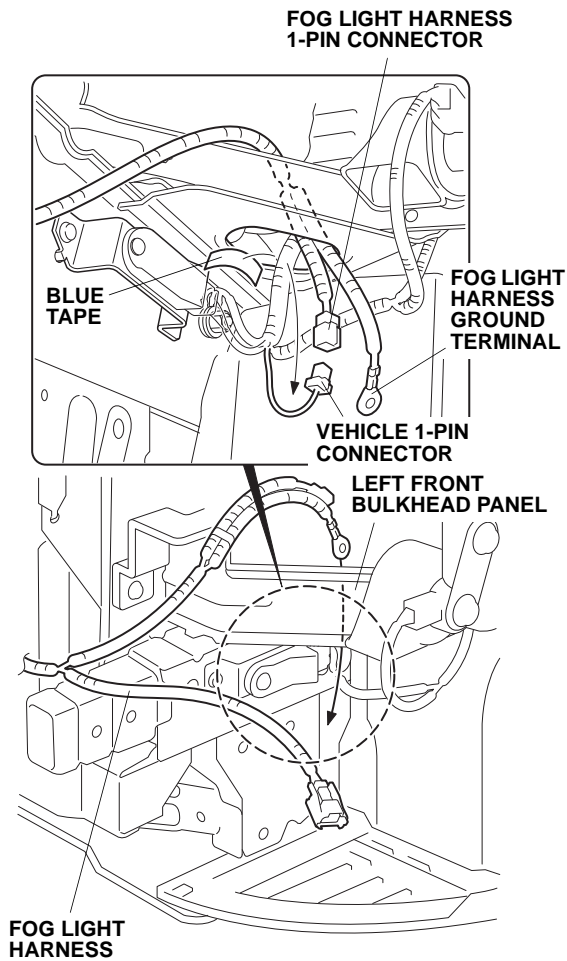

17. Locate the 1-pin connector blue-taped to the vehicle harness and remove the blue tape to free the 1-pin connector. Plug the 1-pin connector you just freed into the fog light harness 1-pin connector.

18. Remove the vehicle ground bolt. Secure the fog light harness ground terminal using the ground bolt.

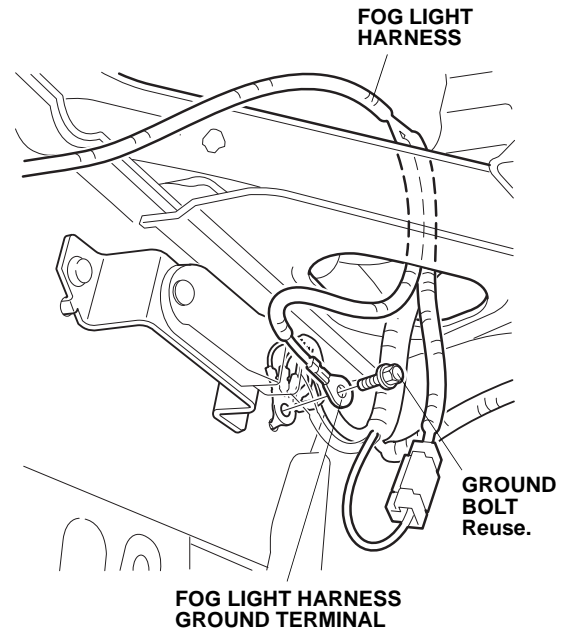

19. Secure the fog light harness 1-pin connector to the vehicle harness with one wire tie. Do not secure the connector to the SRS harness.

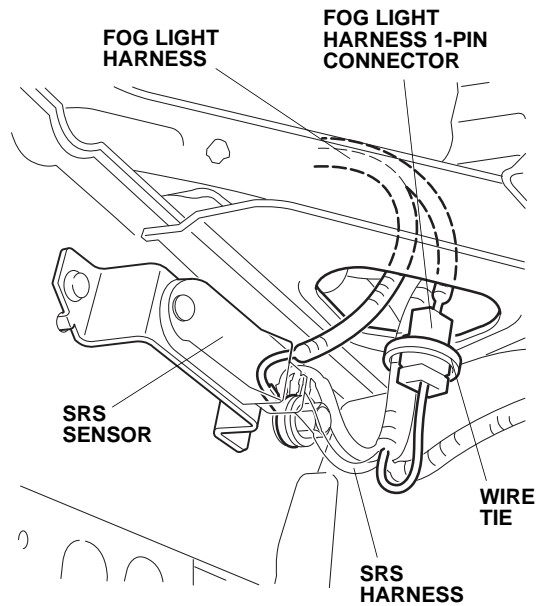

- Route the fog light harness 2-pin connector (short end) behind the front side frame, then down and out through the clearance between the side frame and front bumper beam.

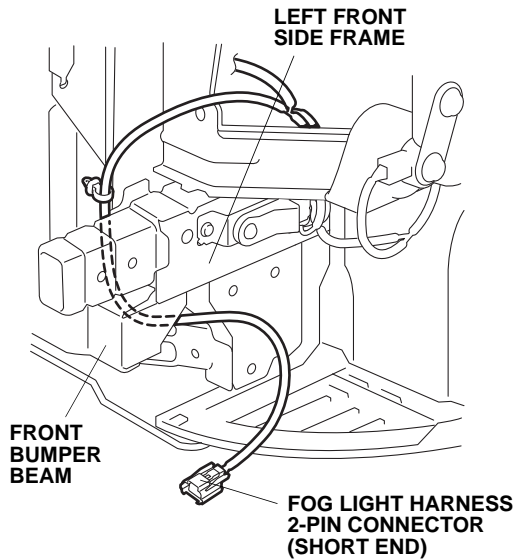

- Route the fog light harness 2-pin connector (long end) up along the vehicle harness behind the front bulkhead upper frame.

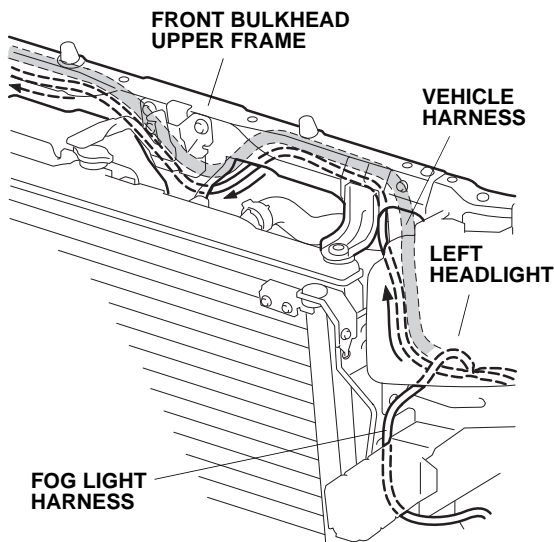

- Continue routing the fog light harness 2-pin connector forward, then down to the bottom of the front side frame along the outside of the right bulkhead side stay.

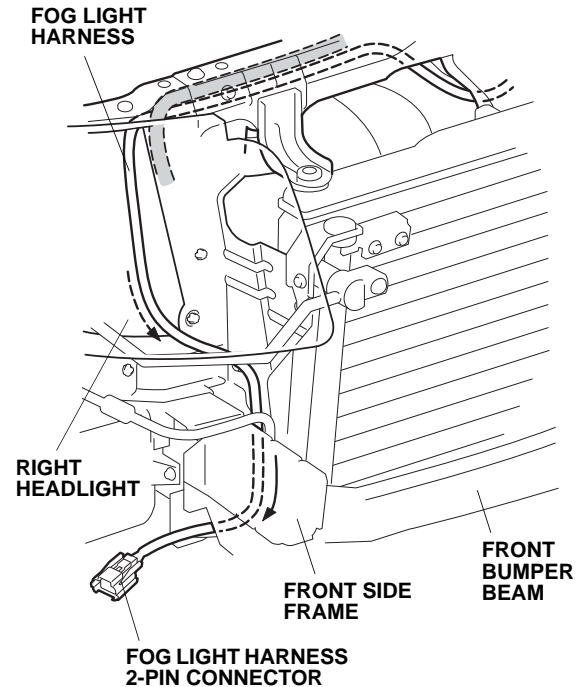

- Push the two clips on the fog light harness into the holes in the bulkhead side stay.

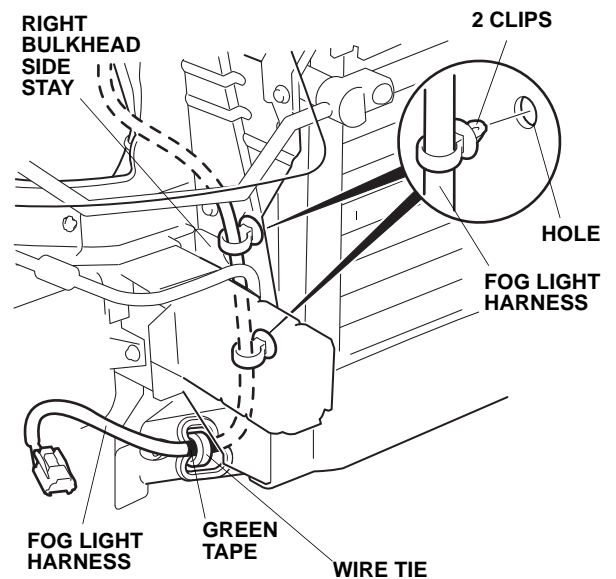

- Secure the fog light harness to the vehicle frame with one wire tie at the green tape.

25. Secure the fog light harness to the vehicle harness with two wire ties in the areas shown.

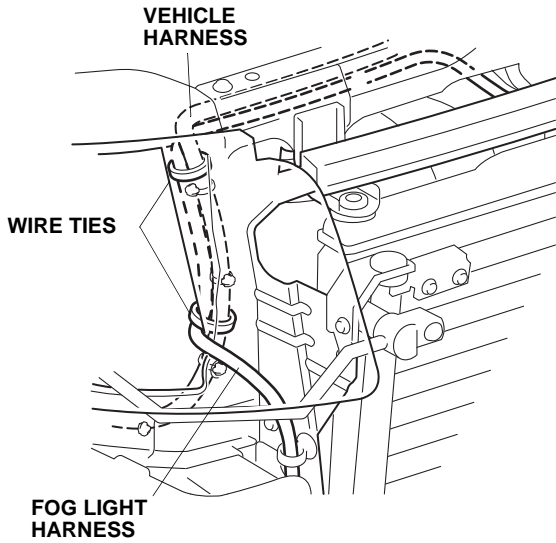

26. Secure the fog light harness to the vehicle harness with seven wire ties in the areas shown.

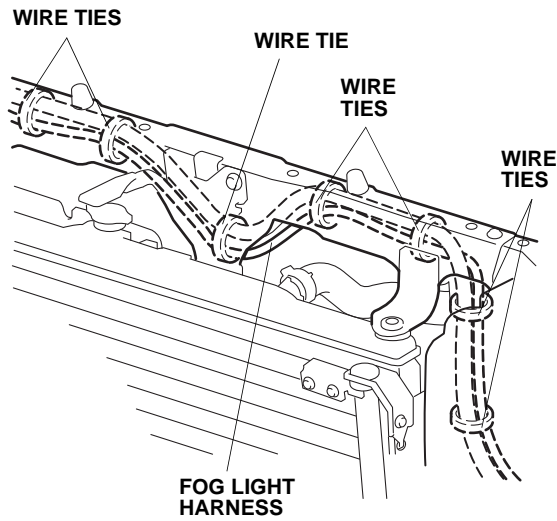

27. Secure the fog light harness to the vehicle harness with one wire tie at the green tape.

Without vehicle harness: Secure the fog light harness to the vehicle panel with the one wire tie with clip at the green tape.

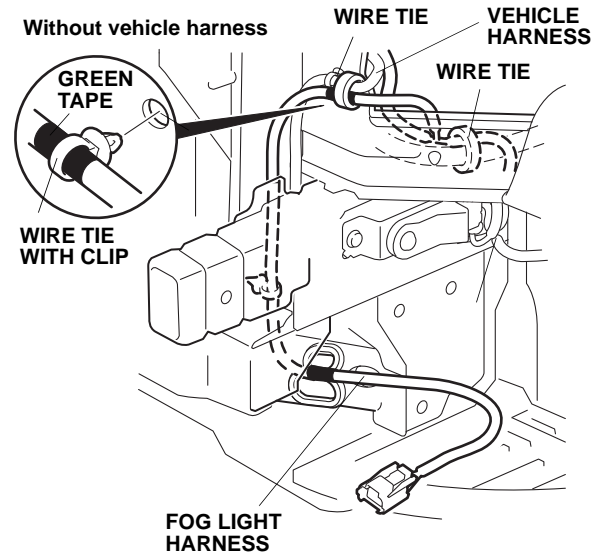

28. Secure the fog light harness to the vehicle harness with one wire tie.

29. Secure the fog light harness to the left bulkhead side stay with one wire tie with clip at the green tape.

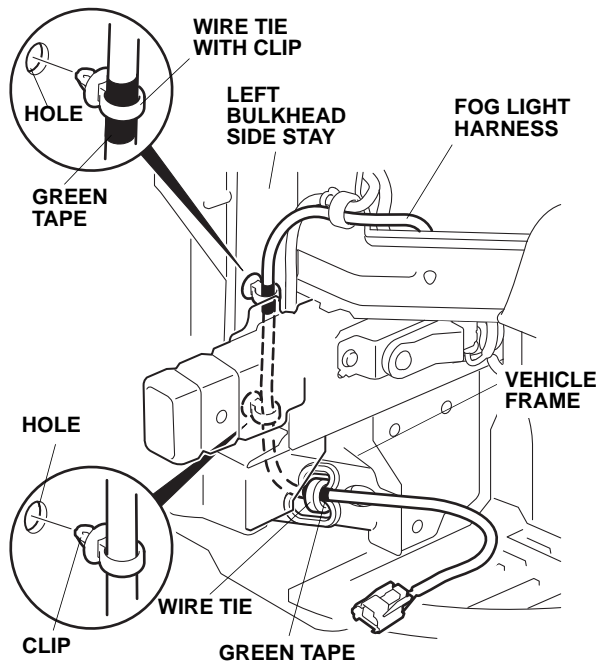

30. Push the clip on the fog light harness into the hole in the left bulkhead side stay.
31. Secure the fog light harness to the vehicle frame with one wire tie at the green tape.

32. While holding the front bumper near the front of the vehicle, plug the fog light harness 2-pin connectors into the 2-pin connectors from the fog lights. Reinstall the front bumper.

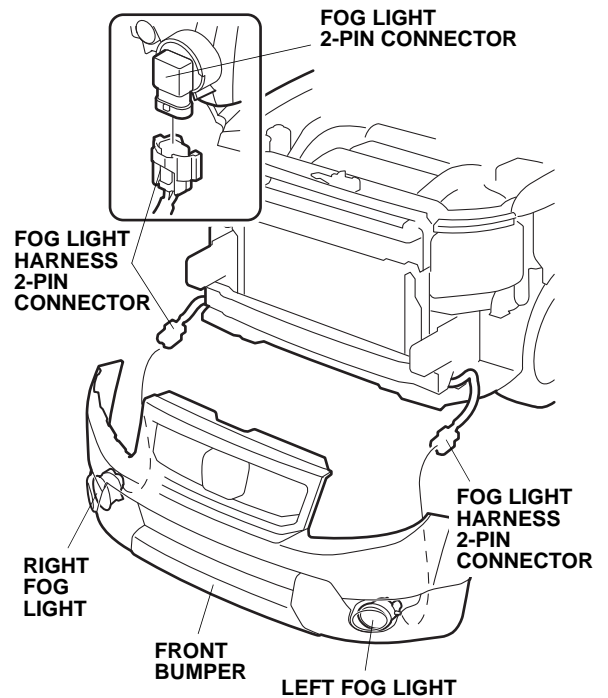

Routing the Switch Harness

33. Remove the driver's dashboard lower cover. Turn the knobs clockwise, then pull the cover out toward you to release the six retaining tabs.

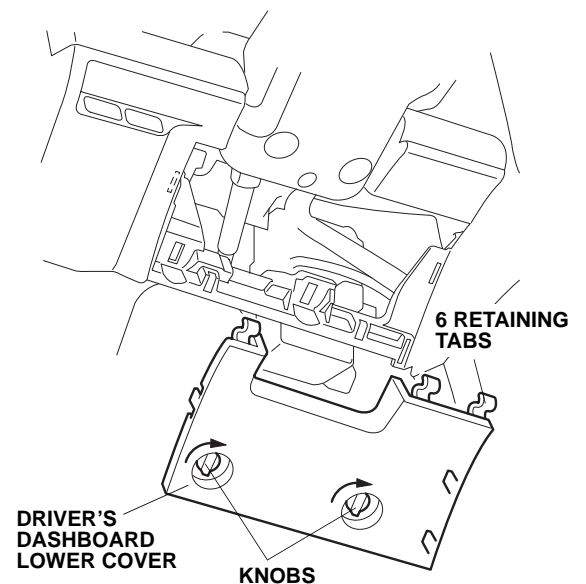

34. Lower the steering wheel using the tilt lever. Remove the two self-tapping screws and one washer-screw from the lower steering column cover.

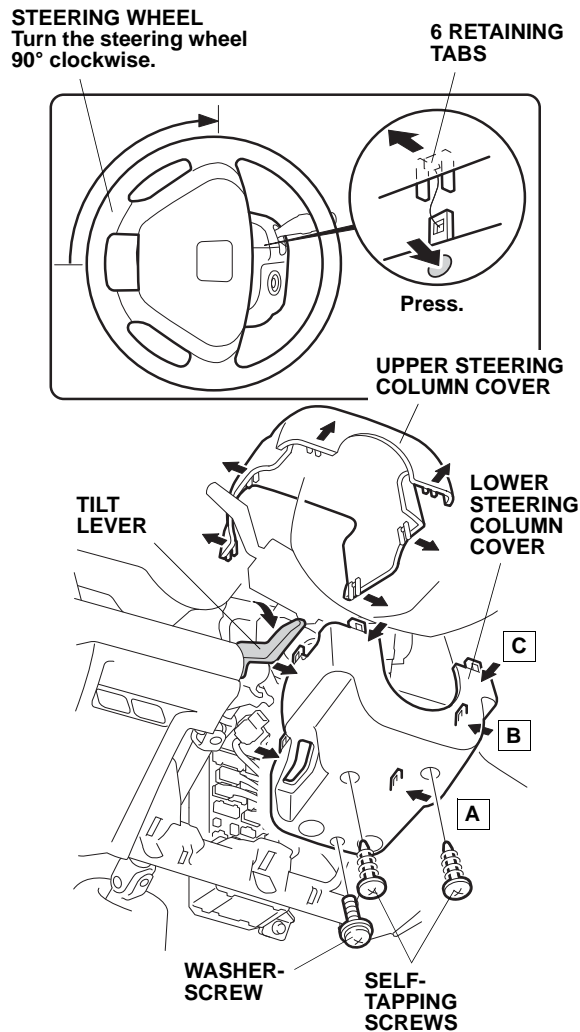

35. Separate the upper steering column cover from the lower steering column cover.
- Turn the steering wheel 90° clockwise, and press the point **A** to release the retaining tab.
 - Press point **B** and then **C** to release the retaining tabs. Once these retaining tabs are released, the retaining tabs on the opposite side will release.

36. Slide the relay bracket onto the switch harness relay block.

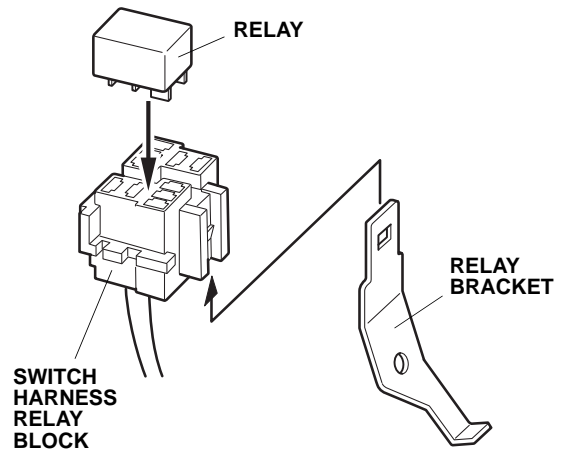

37. Plug the relay onto the switch harness relay block.
38. Under the dashboard, install the relay bracket on the data link connector bracket using a washer-bolt and flange nut.

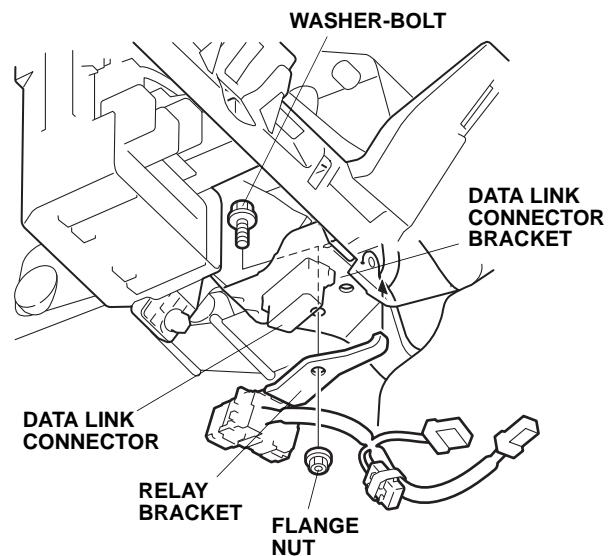

39. Remove the clip shown from the front bulkhead.

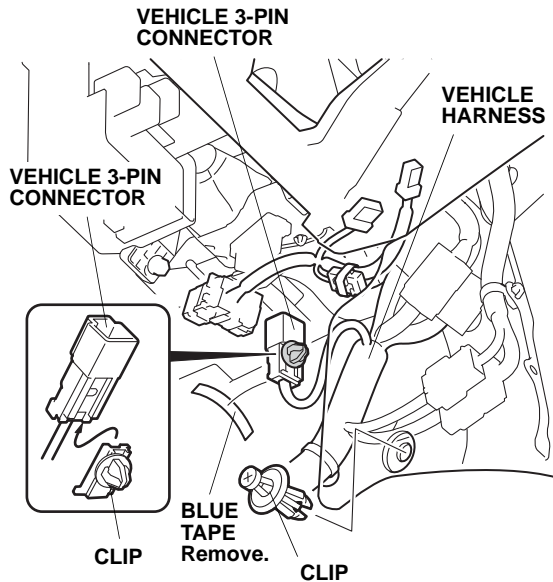

40. Locate the 3-pin connector blue-taped to the vehicle harness and remove the blue tape to free the 3-pin connector. Slide the clip (supplied) onto the 3-pin connector you just freed.
41. Plug the switch harness 3-pin connector into the 3-pin connector freed in step 40. Push the clip into the hole shown.

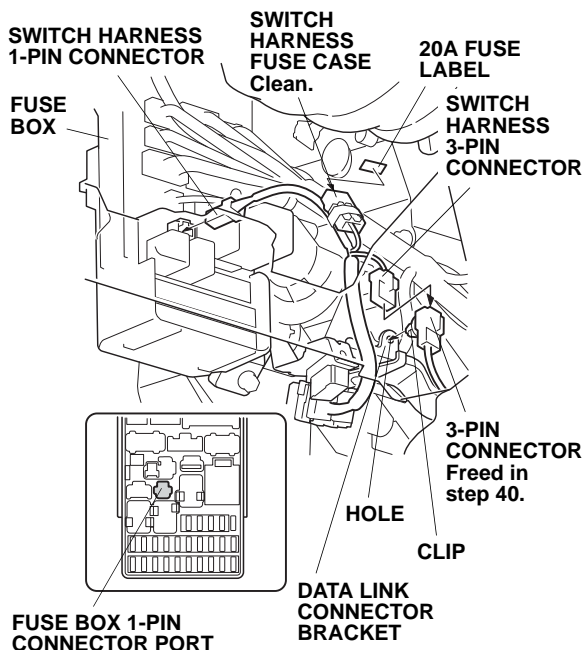

42. Attach the 20A fuse label to the switch harness fuse case.
43. Plug the switch harness 1-pin connector into the fuse box in the location shown.

44. Secure the switch harness to the vehicle harness with two wire ties.

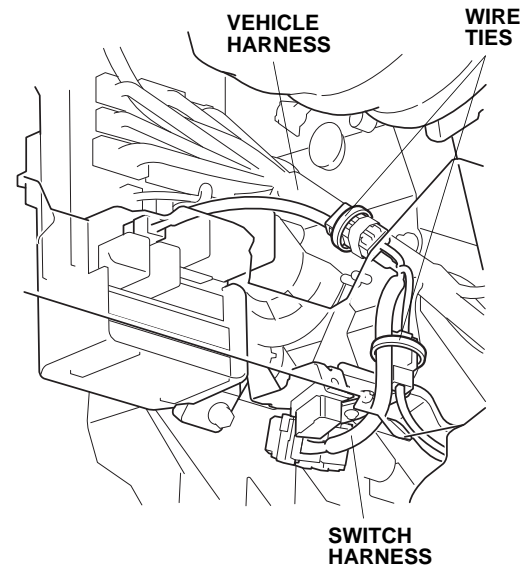

45. Turn the steering wheel 90° counterclockwise.

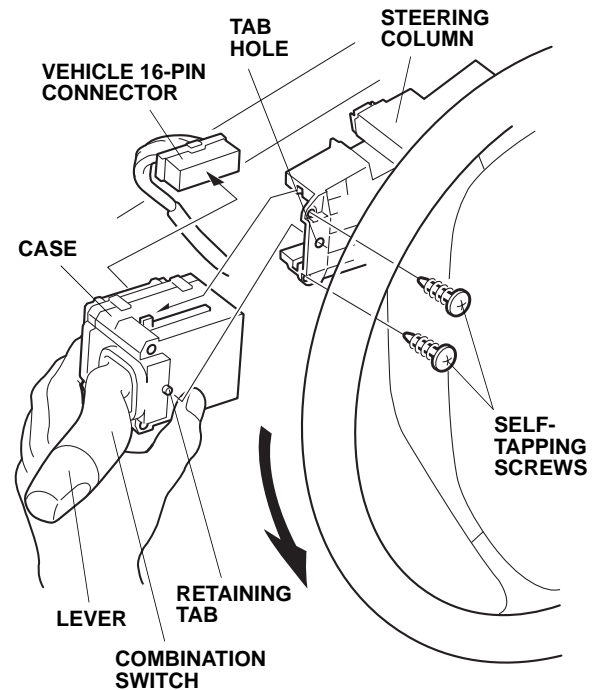

46. Unplug the vehicle 16-pin connector from the combination switch.
47. Remove the two self-tapping screws from the combination switch. While pushing the retaining tab, slide the combination light switch out, and remove it from the steering column. Do not pull on the lever when removing the case. Do not damage the tab hole on the steering column.

48. Install the new combination switch on the steering column using the two self-tapping screws. Hold the case while installing the new combination switch. Do not push on the lever when installing the case.

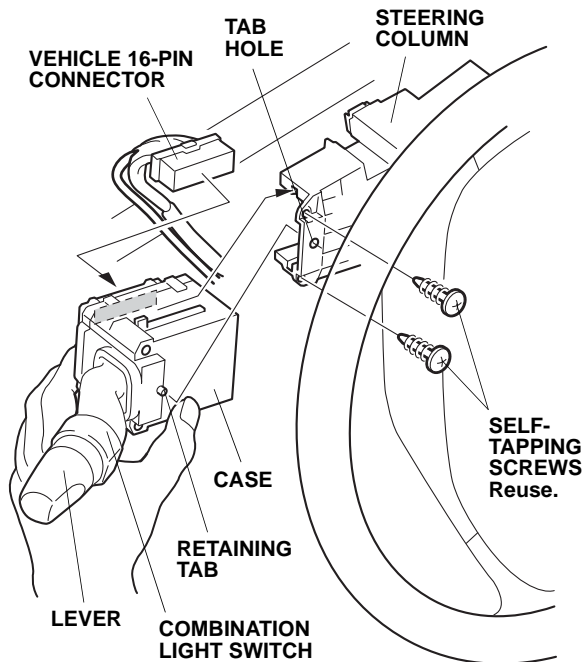



- Lower and raise the driver's window to check operation of the driver's window AUTO function.

USE AND CARE

How to Operate

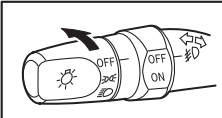
- Turn the light switch to the "☰" position (headlights on low beam).
- Turn the fog light switch (indicator "☼" in the meter comes on).

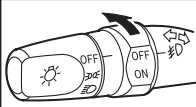
				
HEADLIGHT SWITCH				
	OFF			
		Low	Hi	
 FOG LIGHT SWITCH	OFF	-	-	-
	ON	-	-	ON

49. Check that all wire harnesses are routed properly and all connectors are plugged in.
 50. Reinstall all removed parts. Check that all clips and fasteners are installed securely.
 51. Reconnect the negative cable to the battery.
 52. Reset the clock, and reset the radio station presets.
- NOTE: When the battery is disconnected, the driver's window AUTO function is disabled.
- Start the engine. Push down on the driver's window switch until the window is fully open.
 - Pull up on the driver's window switch to close the window completely, then hold the switch for 2 seconds.

NOTE: The fog light lenses can cloud when the outside temperature is cold; this is normal and should go away in warm weather.

Adjusting the Fog Light Aiming

Adjust the aiming according to local laws and regulations.

1. Remove the two stepped bolts and two bolts, then push in the inner fender.

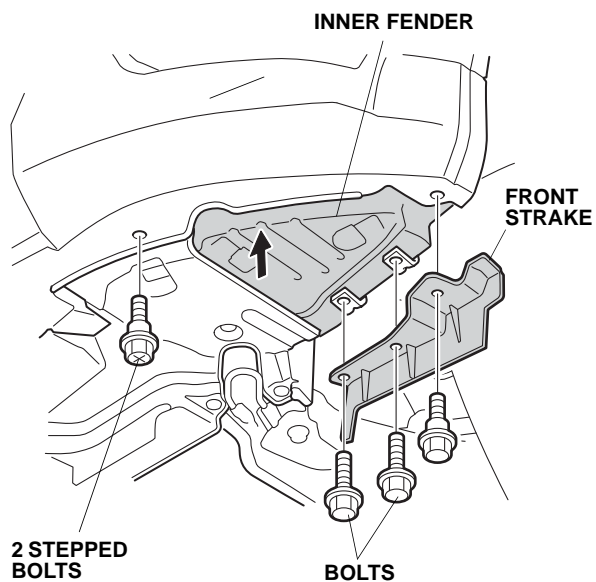

2. To adjust, turn the aiming adjustment knob in or out until the correct aiming is obtained.

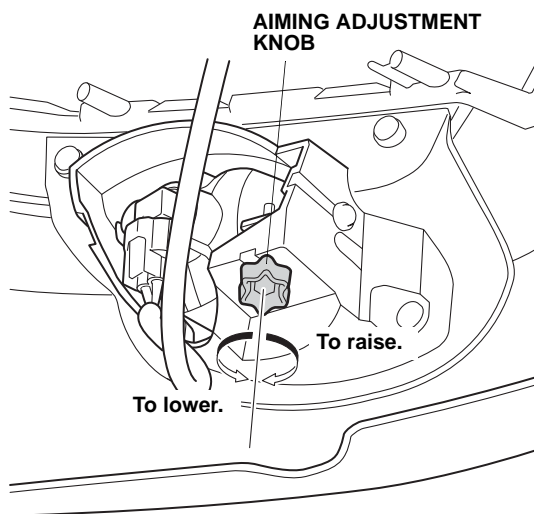

3. Reinstall all removed parts.

Replacing the Bulb

1. Remove the two stepped bolts and two bolts, then push in the inner fender.

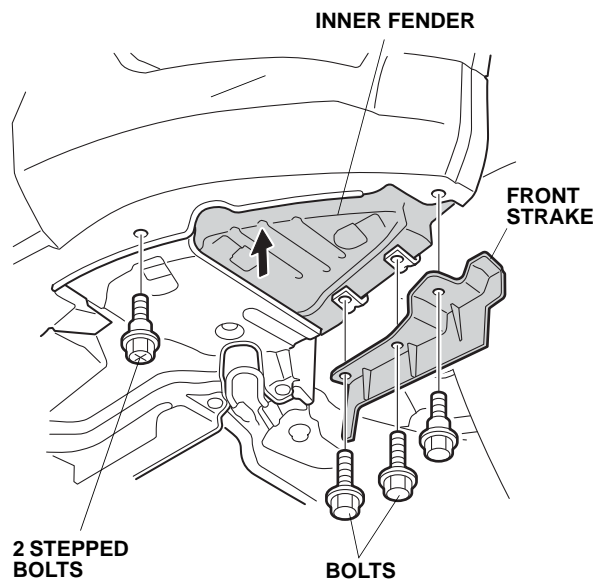

2. Unplug the connector. Turn the bulb 45° counterclockwise and remove it from the socket.

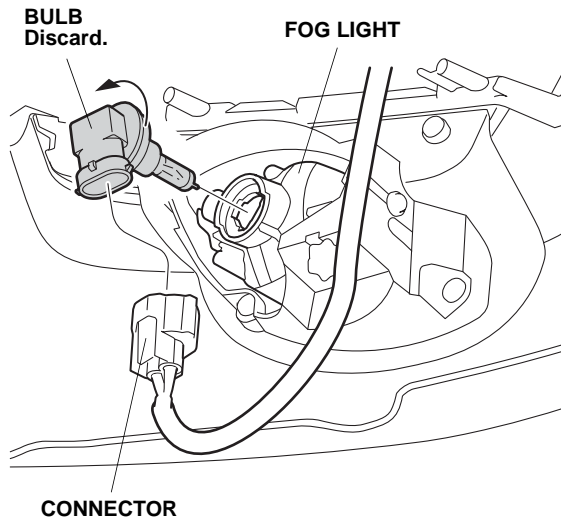

3. Install the new bulb into the socket.
 - Take extreme care when replacing the fog light bulb to avoid damaging the lenses or finished surfaces of the body.
 - Use only a genuine Honda halogen light bulb of specified wattage.
Rating: 12V 55W H11 Halogen Light Bulb
P/N 33165-S5A-003
 - Do not touch the bulb. Oily or greasy substances on the bulb can shorten its service life due to the heat produced when the bulb is turned on. If the bulb is accidentally touched, wipe it clean with a soft cloth that has been dampened with denatured alcohol or a mild detergent solution.

- When installing the new bulb, align the cutout on the fog light with the tab on the new bulb and turn the new bulb until it stops. If not properly aligned, the fog light may blind oncoming drivers.

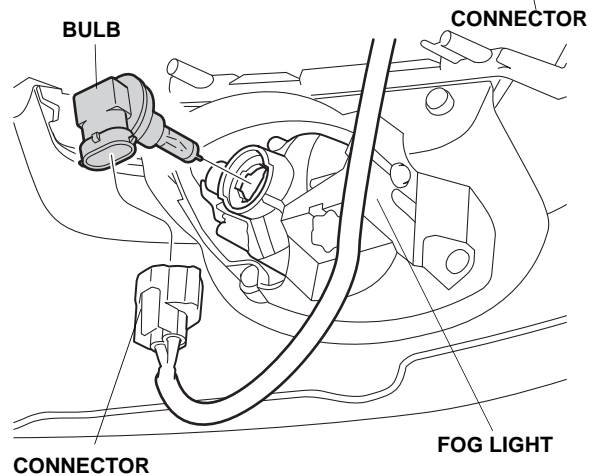
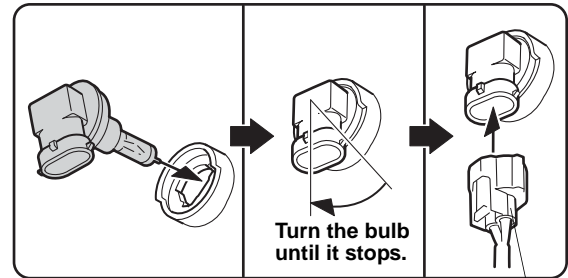

4. Reinstall the removed parts in the reverse order of removal.
 - Check that the wire harnesses are not pinched.
 - Make sure to tighten the bolts securely.
5. Check the operation of the fog light; adjust the aiming if necessary.