

PARTS LIST

Fan assembly

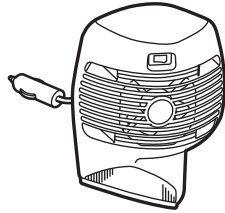

4 Washer-screws



4 Well nuts



Accessory User's Information Manual

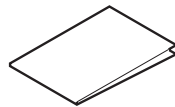

TOOLS AND SUPPLIES REQUIRED

Phillips screwdriver

Masking tape

Felt-tip pen

Drill

3 mm and 8 mm Drill bits

Eye protection (face shield, safety goggles, etc.)

Tape measure

Hex wrench

Torque wrench

File

INSTALLATION

Customer Information: The information in this installation instruction is intended for use only by skilled technicians who have the proper tools, equipment, and training to correctly and safely add equipment to your vehicle. These procedures should not be attempted by "do-it-yourselfers."

NOTE:

- Be careful not to damage the side trim panels..
- Do not store any items in the right rear cargo area pocket after the fan is installed.

1. With the vehicle cover open, measure 265 mm (10.4 in.) rearward, and place a piece of masking tape on the right rear side trim panel.

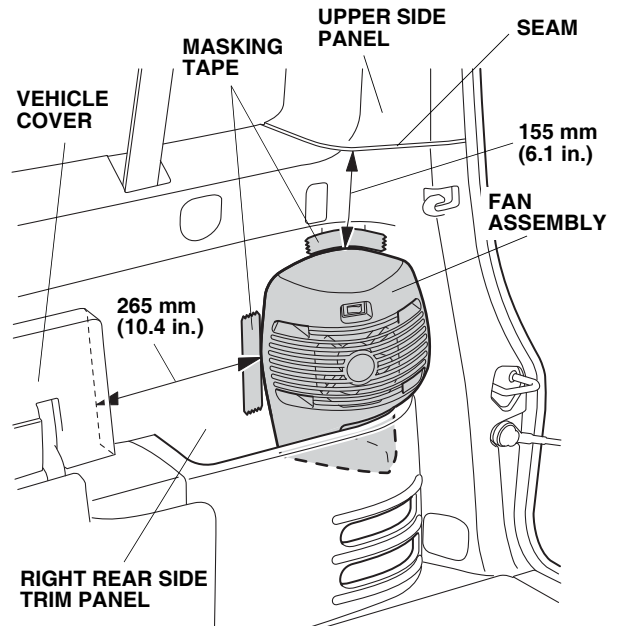

2. Measure 155 mm (6.1 in.) down from the seam where the right rear side trim panel meets the upper side liner, and place a piece of masking tape on the right rear side trim panel.
3. Place the fan assembly on the right rear side trim panel as shown.

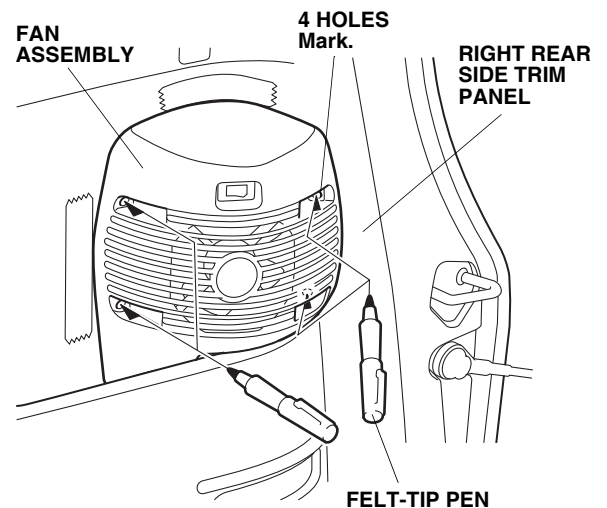

4. Using a felt-tip pen, mark the right rear side trim panel through the four holes in the fan.

5. Remove the fan assembly and masking tape.
6. While wearing eye protection, drill the four marked points:
 - Wrap masking tape around a 3 mm drill bit and an 8 mm drill bit 10 mm (0.4 in.) away from the tip.
 - First drill with a 3 mm drill bit, and finish with an 8 mm drill bit.
 - Remove any burrs from around the holes.

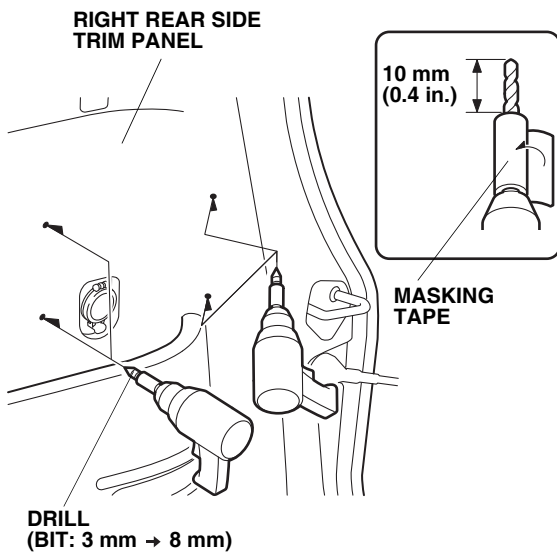

7. Install one well nut into each drilled hole.

8. Plug the fan assembly socket into the vehicle A/C socket, and place the fan assembly against the right rear side trim panel. Align the holes in the fan assembly with the well nuts on the trim panel, and install the four washer-screws.

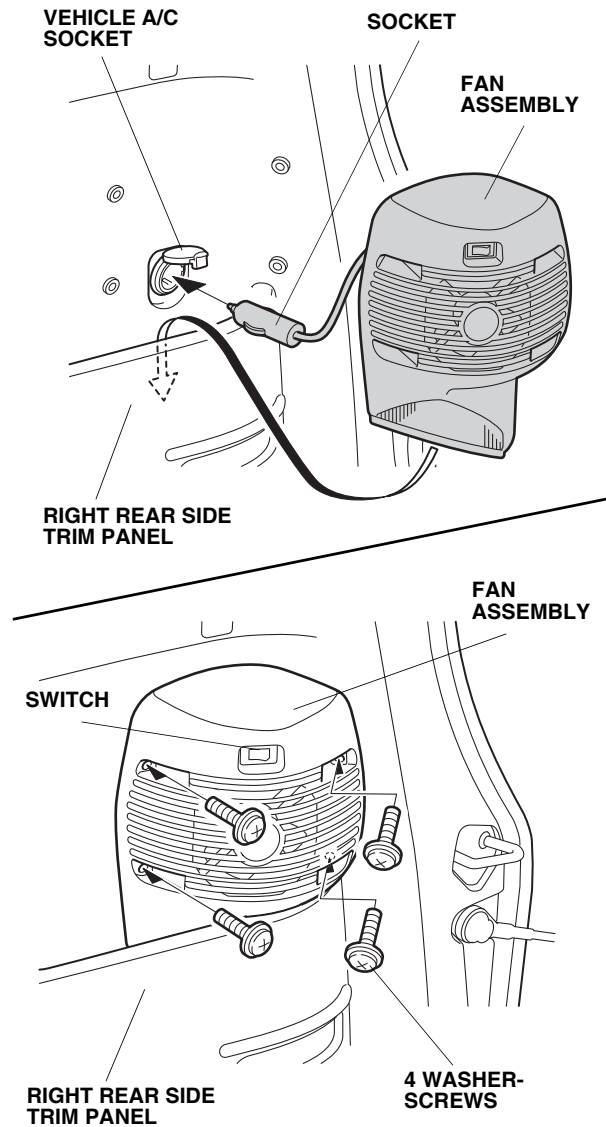

9. With the ignition on, use the fan switch to test the operation of the fan.