



# INSTALLATION INSTRUCTIONS

Accessory

**ALUMINUM WHEEL  
P/N 08W18-SNX-100A**

Application

**2010 CIVIC  
4-DOOR Si**

Publications No.

**All 42394**

Issue Date

**SEPT 2009**

## PARTS LIST

Aluminum wheel  
(The illustration may differ  
from the actual wheel.)

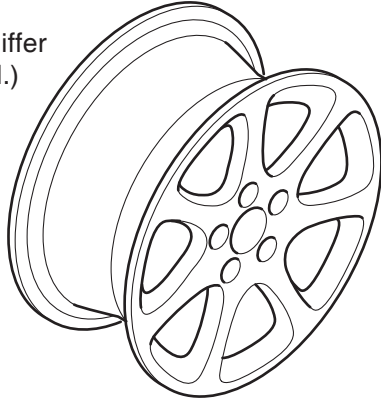

Center cap

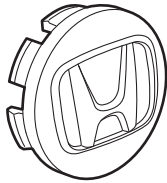

Tire pressure caution label

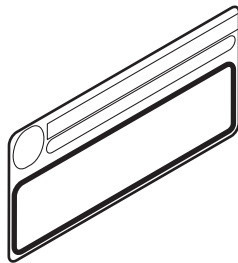

Supplemental Information

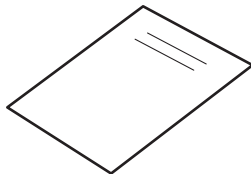

Tire pressure Information label

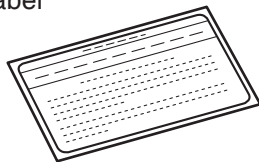

## Parts for TPMS sensor assembly

Tire pressure sensor

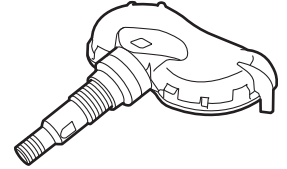

Washer



Valve cap  
(The valve cap may be assembled  
with the tire pressure sensor.)



Valve nut

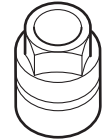

## TOOLS AND SUPPLIES REQUIRED

Ratchet

11 mm Socket

Torque wrench

Isopropyl alcohol

Shop towel

HDS (Honda Diagnostic System)

Snap-on TPMS sensor initializer tool

## SPECIFICATIONS

Rim size	18 x 7 J (offset 45)	
Tire size	215/40ZR18 89W	
Bolt hole PCD	114.3 (5 holes)	
Tire pressure	Front	250 kPa (2.5 kgf/cm <sup>2</sup> , 36 psi)
	Rear	250 kPa (2.5 kgf/cm <sup>2</sup> , 36 psi)

## INSTALLATION

**Customer Information:** The information in this installation instruction is intended for use only by skilled technicians who have the proper tools, equipment, and training to correctly and safely add equipment to your vehicle. These procedures should not be attempted by “do-it-yourselfers.”

### NOTE:

- This aluminum wheel is designed for use on the TPMS (Tire Pressure Monitoring System) vehicle.
  - This aluminum wheel is equipped with the TPMS sensor. See the Service Manual for tire replacement procedure and TPMS sensor installation procedure (paragraph of Tire Pressure Sensor Replacement).
  - The illustration of the aluminum wheels are shown for reference purposes only.
  - Install the correct size tire.
  - Use a tire changer to remove and install the tires. Using a tire lever to remove and install the tires can damage to the tire, the wheel, and the TPMS sensor.
  - The wheel nut torque is 108 N·m (80 lbf-ft)
1. Clean the mating surface and the valve hole of the aluminum wheel.

2. Install the tire pressure sensor and the washer to the aluminum wheel, and loosely install the valve nut. Make sure the pressure sensor is resting on the wheel.

**NOTE:** Install the tire pressure sensor so that the sensor housing surface does not protrude into the bead area of the wheel to prevent the sensor housing from being caught on the bead of the tire.

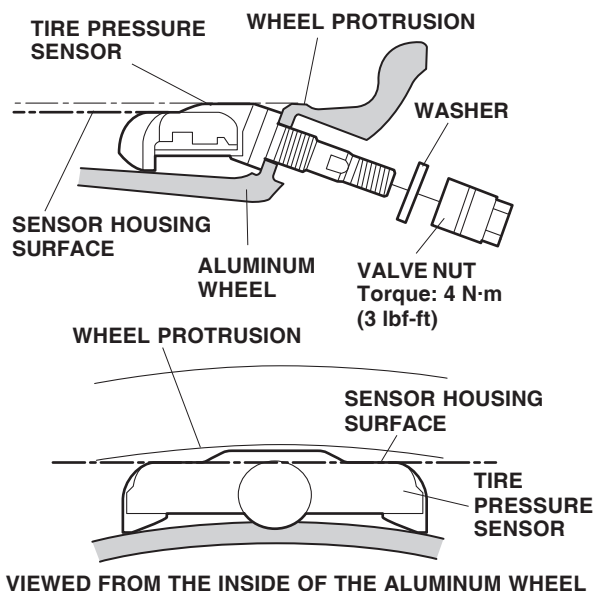

3. Torque the valve nut to 4 N·m (3 lbf-ft) while holding the tire pressure sensor toward the wheel.

### NOTE:

- Do not reuse the grommet that had been tightened, even one time, to the specified torque, as they are deformed inside.
  - Do not use air or electric impact tools to tighten the valve stem nut.
  - Tightening the nut beyond the specified torque can damage the nut.
4. Install the tires according to the instructions in the service manual.
  5. Install the wheels on the vehicle and torque the wheel nuts to 108 N·m (80 lbf-ft).

6. Open the driver's door. Using isopropyl alcohol, clean the area where the accessory tire pressure caution label will attach. Remove the backing from the label and attach it over the existing tire information label.

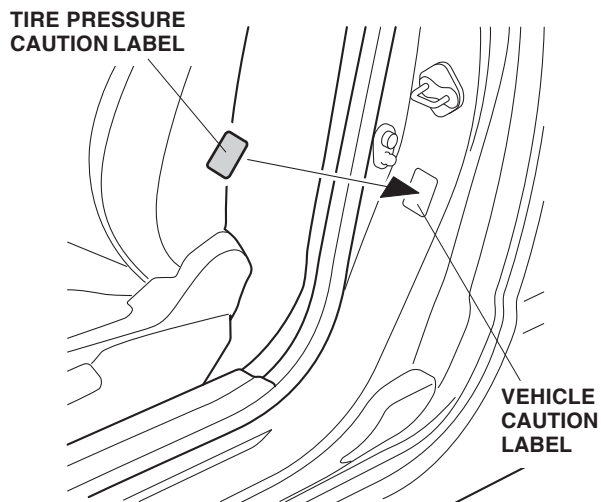

7. Attach the "Supplemental Information" page included in this kit to the owner's manual. For the method of attaching the page, refer to "To the dealer:" attached to the "Supplemental Information" page.

## MEMORIZING THE TIRE PRESSURE SENSOR ID

8. Using the HDS and Snap-on TPMS sensor initializer tool, memorize the ID of tire pressure sensor ID according to the instructions in the service manual (Memorizing the Tire Pressure Sensor ID).

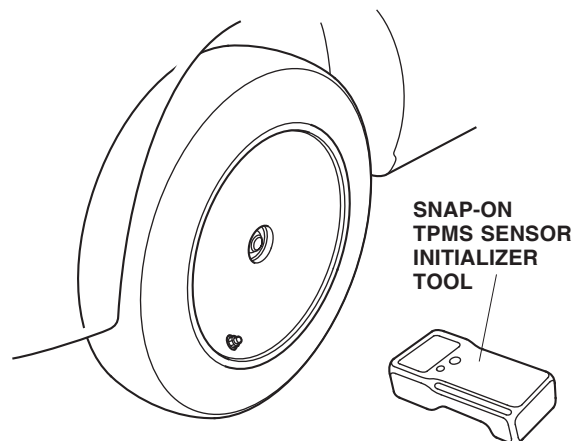
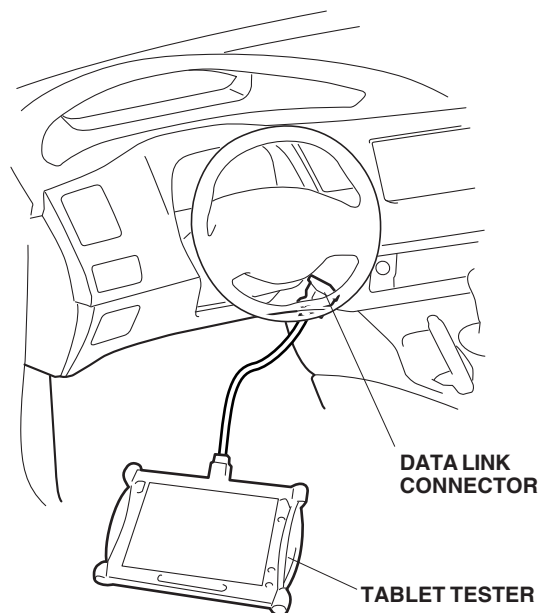

9. Perform the Inch-up Tire Pressure programming procedure as follows.

### INCH-UP TIRE PRESSURE PROGRAMMING

#### (LOW AIR PRESSURE WARNING THRESHOLD REPROGRAMMING)

- 1). After performing the sensor ID learning using the HDS, back up to the TPMS Mode Menu, and click on Threshold Rewriting.
- 2). Select "Reprogramming for accessory tires".
- 3). When the HDS says "Do you want to rewrite the threshold data?" Click "YES".
- 4). Check that "Please enter the tire information code of new tires" is shown, and click "Keyboard" icon.
- 5). Enter the 10-digit tire information code printed on the new tire pressure information label, then click the check icon.
- 6). Check that the tire pressure shown on HDS, and the new tire pressure on the tire information label are the same, click "YES" button for programming.
- 7). Check that current air pressure setting shown on HDS is correct and "Reprogramming the threshold data for non-standard tires has completed successfully" is shown.
- 8). After programming, write the tire pressure indicated on the HDS in the service history page for Honda Accessory Wheels, then click the check icon.
- 9). After programming, sign the service history page for the Honda Accessory wheels, according to the procedure on page 5.
10. After finishing the work, write tire size, tire pressure, HDS version, dealer name, technician's signature and date in service history page for Honda Accessory Alloy wheels page included in this kit, and attach to the vehicle's service history booklet.
11. Attach the "Supplemental information for using 18" Honda Accessory Alloy wheels page included in this kit to the vehicle's owner's manual. To install this page to the Owner's Manual, refer to the "To Dealer" label attached to the "Supplemental information for using 18" Honda Accessory Alloy wheels page.

Be sure to explain the contents of the "Supplemental Information" to your customer when delivering the vehicle.

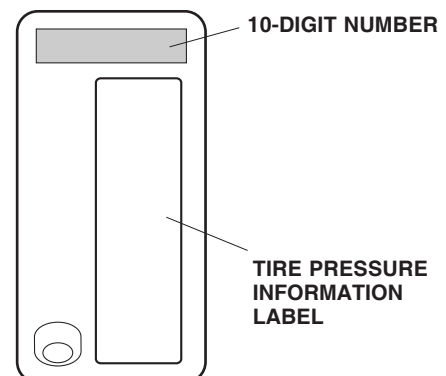
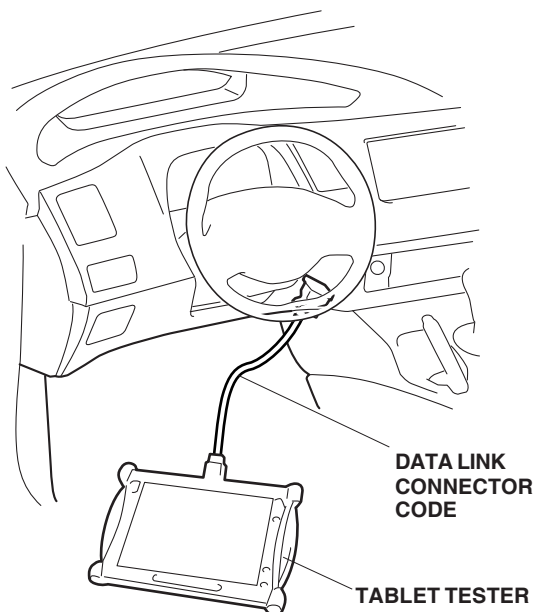

## **REINSTALLING STANDARD TIRES**

If the original equipment (standard tires) are to be installed back on the vehicle, the low pressure warning threshold must be restored to the factory setting, follow the procedure on page 6.

NOTE: Have the standard tire pressure label on hand.

## **THRESHOLD DATA CHECK**

If for some reason you are unsure of where the low pressure warning threshold is set, it can be checked by using Threshold Data Check, follow the procedure on page 7.

## **TPMS Unit Replacement**

If the TPMS control is ever replaced and the vehicle has inch up wheels, the low pressure sensor threshold must be changed, once the TPMS control is installed follow steps 8 to 11 (which includes memorizing ID and programming for accessory tires).

## STANDARD TIRE PRESSURE PROGRAMMING

To return the TPMS programming from the inch-up tire to the standard tire, memorize the tire pressure sensor ID and change the tire pressure programming.

1. Replace with the standard tire, and perform the memorizing the tire pressure sensor ID according to the instructions in the service manual.
2. Change the tire pressure programming (the low air pressure warning threshold) in the following procedure.
  - 1). Connect the HDS to the vehicle, make sure the correct VIN is populated and enter the mileage.
  - 2). At the System Selection Menu, click TPMS.
  - 3). At the Mode Menu, Click the DTC and clear any stored codes.
  - 4). Go back to the Mode Menu, click on Threshold Rewriting.
  - 5). Click on Reprogramming for standard tires and follow the screen prompts.
  - 6). After programming, write the standard tire pressure in the supplemental information, then click the check button.
  - 7). Attach the tire pressure information label for standard tire at the prescribed location.
  - 8). After programming, sign on the service history page for Honda Accessory wheels, as follows.

Write tire size, tire pressure, HDS version, dealer name, technician's signature and date in service history page for Honda Accessory Alloy wheels page attached on the vehicle's service history booklet.

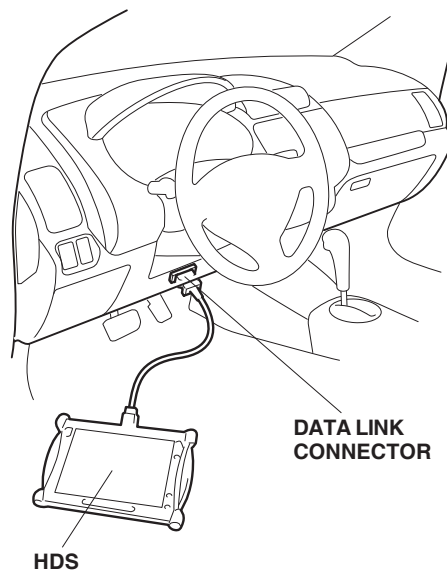

## **THRESHOLD DATA CHECK**

Check the TPMS programming on the vehicle.

- 1). Connect the HDS to the vehicle and make sure the correct VIN is populated and enter the mileage.
- 2). At the System Selection Menu, click TPMS.
- 3). Click on Threshold Rewriting.
- 4). Click on Threshold Data Check.

