



INSTALLATION INSTRUCTIONS

Accessory CARGO NET P/N 08L96-SNA-100	Application 2010 CIVIC 2-DOOR Si	Publications No. All 42428
		Issue Date AUG 2009

Put this information in the glove box with the vehicle's owner's manual.

PARTS LIST

Cargo net

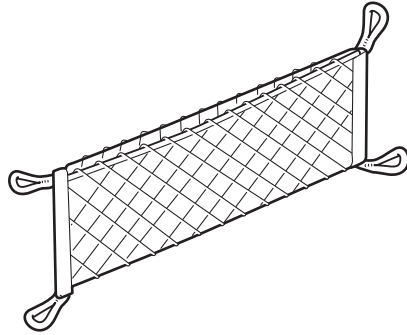

2 Anchors "A"



4 Anchors "B"



2 Bolts



4 Self-tapping screws



2 Rivet nuts

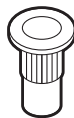

Template "L"

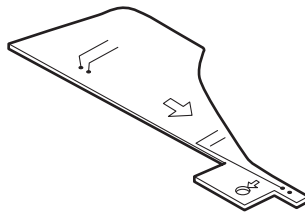

Template "R"

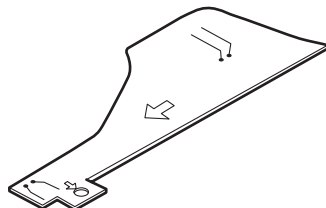

TOOLS REQUIRED

- Flat-tip screwdriver
- Rivet nut tool
- Allen wrench
- 19 mm and 27 mm wrench
- Utility knife
- Felt-tip pen
- Drill
- 3 mm, 5.5 mm, and 9 mm Drill bits
- Center-punch
- Clip remover
- Eye protection

INSTALLATION

Customer Information: The information in this installation instruction is intended for use only by skilled technicians who have the proper tools, equipment, and training to correctly and safely add equipment to your vehicle. These procedures should not be attempted by "do-it-yourselfers."

1. Install a bolt into each anchor "A", and install a self-tapping screw into each anchor "B".

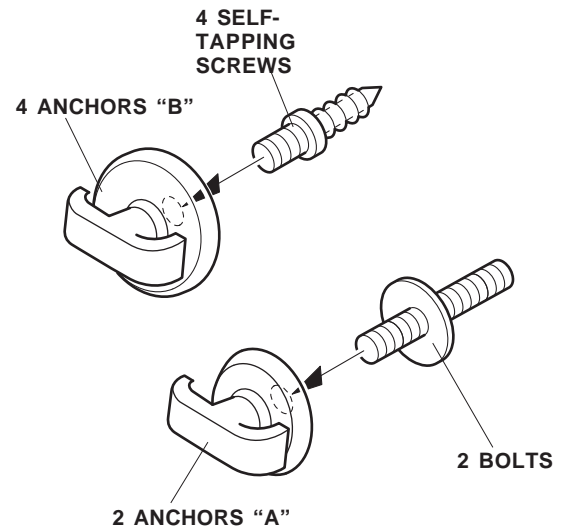

- Open the trunk, and remove the two clips from the trunk side lining.

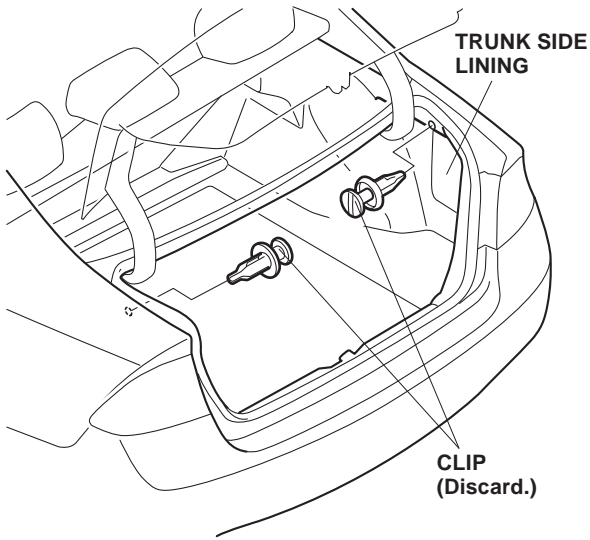

- While wearing eye protection, drill the two clip holes in the right and left trunk side panels to 9 mm. Remove any burrs, and apply touch-up paint to each hole.

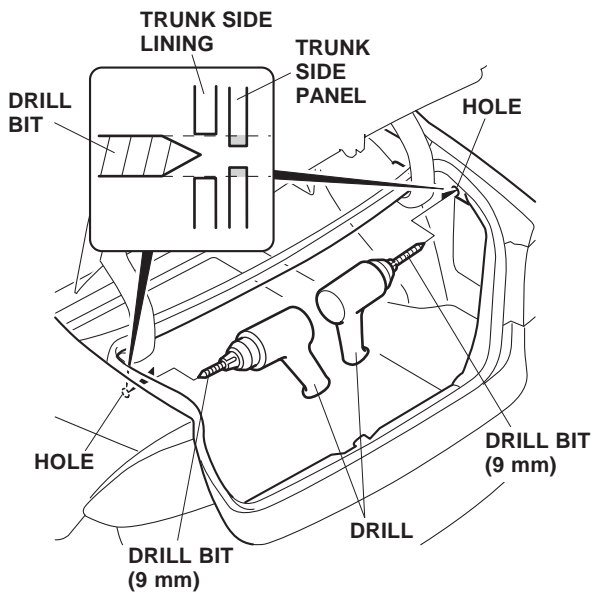

- Install two rivet nuts into the 9 mm holes you enlarged in step 3.

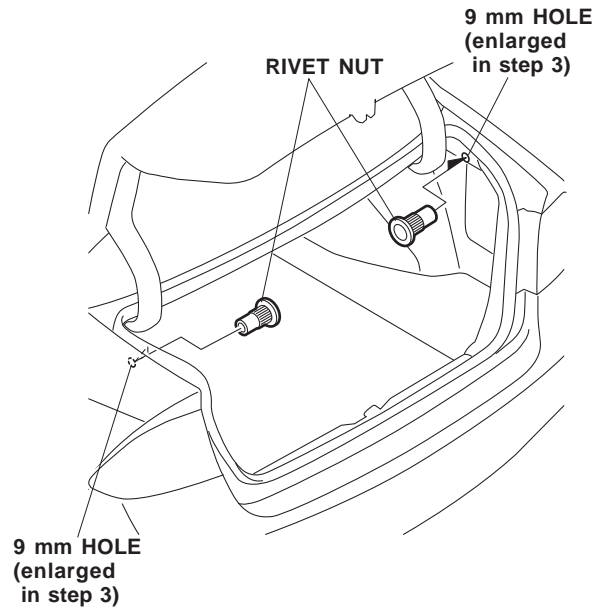

Installing the Rivet Nuts

- Thread the rivet nut onto the mandrel of the tool as shown.

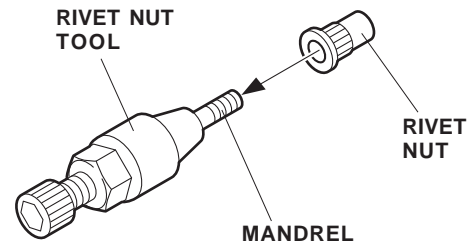

6. Insert the rivet nut into the hole in the vehicle panel.

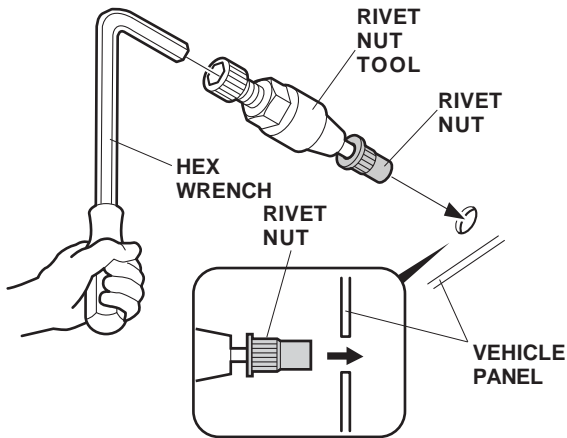

7. While holding the tool with the hex wrench, rotate the 27 mm wrench clockwise and install the rivet nut on the vehicle panel.

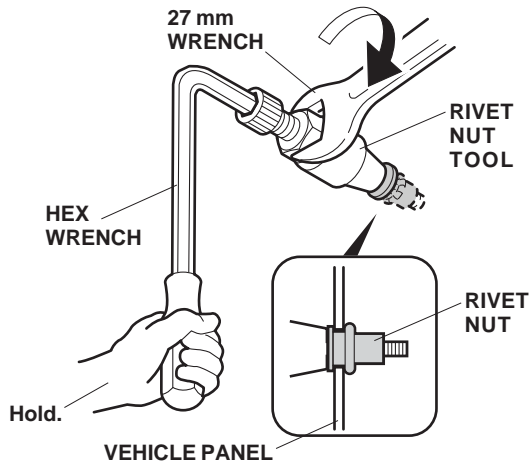

8. Remove the tool from the rivet nut by turning the hex wrench counterclockwise.

9. Install the two bolt/anchor "A" assemblies into the rivet nuts.

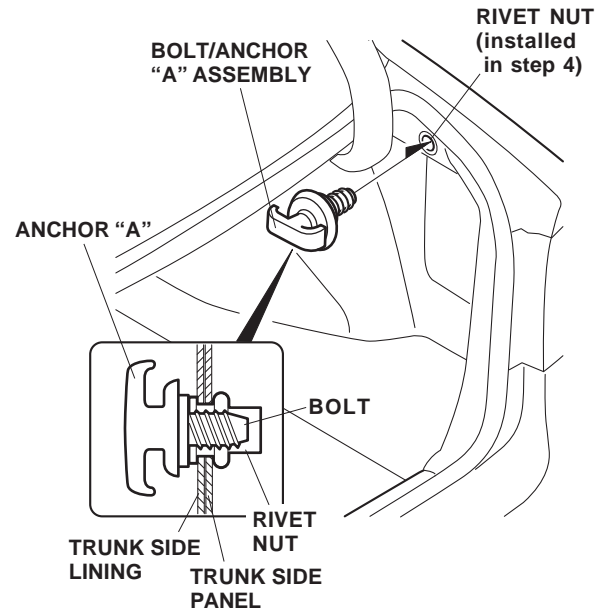

10. Fold the rear seat-back forward by pulling the levers under the rear shelf. Remove the trunk floor mat (two clips).

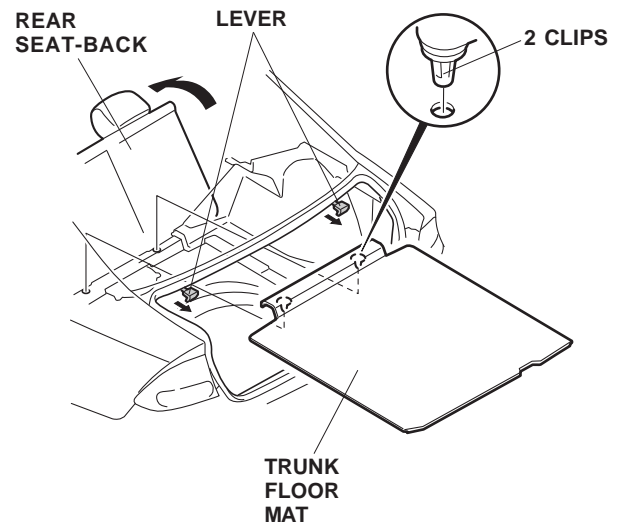

11. Position template "R" on the right trunk side floor by aligning the clip with the hole and the edge parallel with the trunk side lining. Mark the floor using a felt-tip pen. Remove the template.

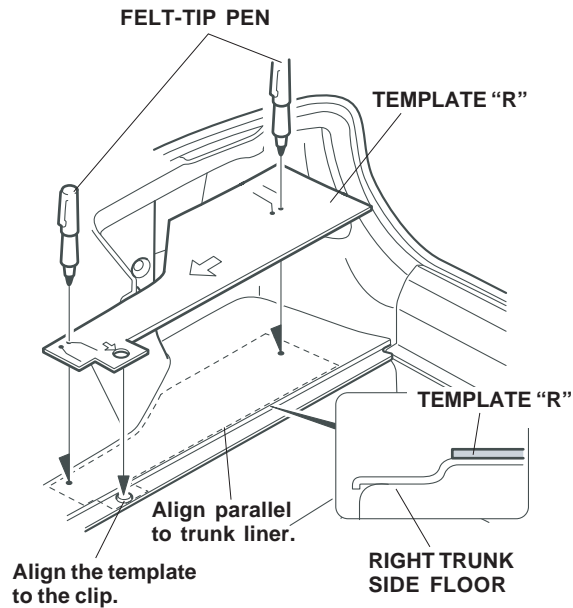

12. Position template "L" on the left trunk side floor by aligning the clip with the hole and the edge parallel with the trunk side side lining. Mark the floor using a felt-tip pen. Remove the template.

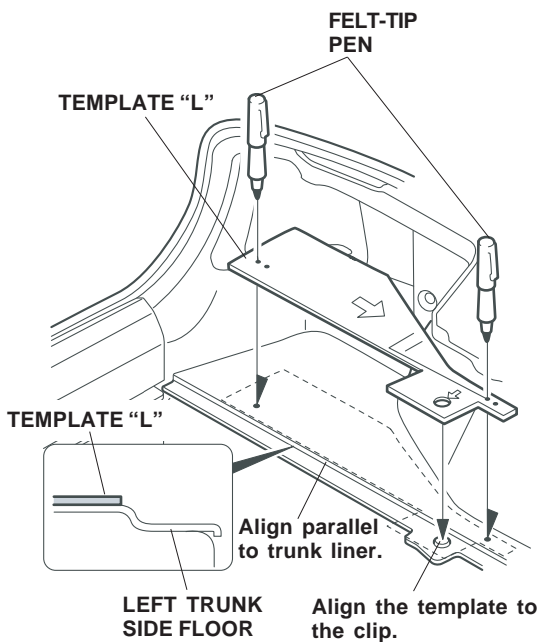

13. Center-punch the marks you made. Lift the trunk liner and check that the center-punched marks are centered on the sheet metal rib. While wearing eye protection, drill a 5.5 mm hole through each mark. Start with a 3 mm drill bit, and finish with a 5.5 mm drill bit. Remove any burrs, and apply touch-up paint to each hole.

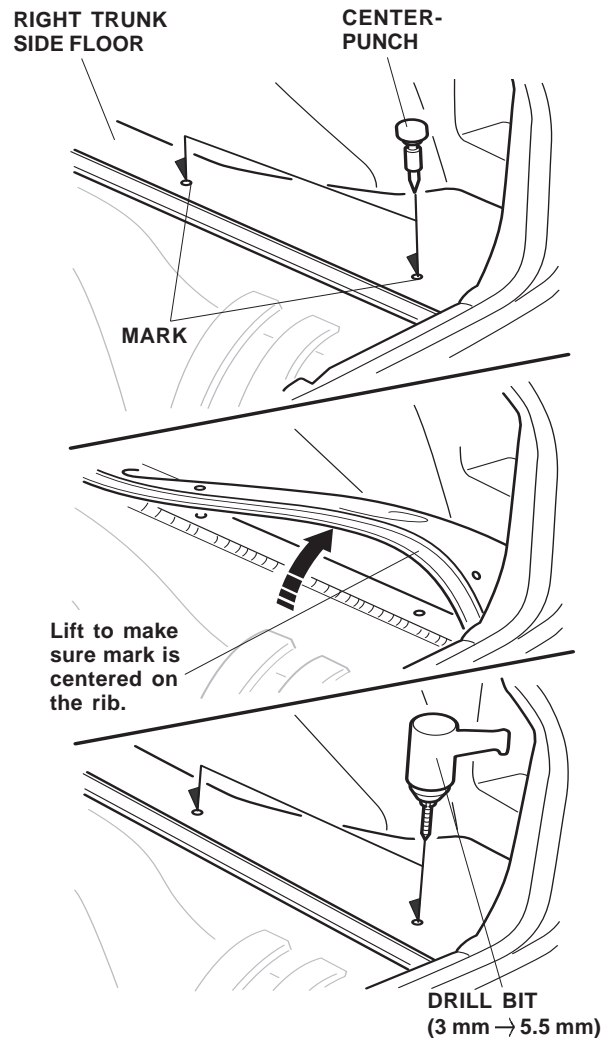

14. Repeat step 13 to drill the left side of the vehicle.

- Install a self-tapping screw/anchor "B" assembly into each 5.5 mm hole you made.

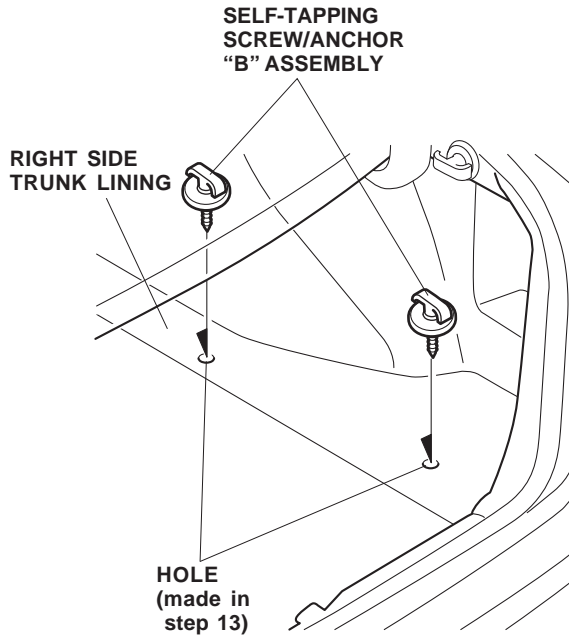

- Repeat step 15 to install the anchor assemblies on the left side of the vehicle.
- Install the cargo net to the anchors in the trunk. The cargo net can be installed in two different positions. Reinstall the trunk floor.

Upright Position:

BOLT/ANCHOR "A" ASSEMBLY

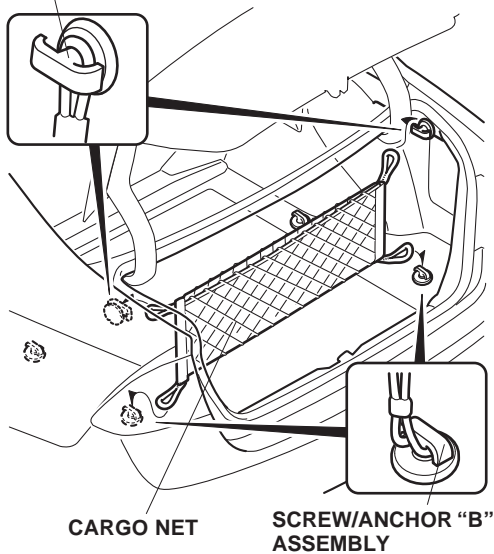

Flat Position:

SCREW/ANCHOR "B" ASSEMBLY

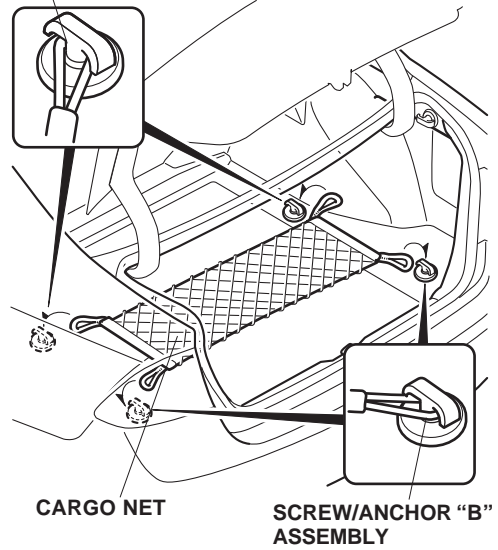

NOTE:

- Do not store large or fragile objects in the net.
- Do not store objects with sharp edges or corners, as they may damage the cargo net or the trunk lining. Wrap such objects in paper or a blanket so they will not contact the net directly.