



INSTALLATION INSTRUCTIONS

Accessory

FOG LIGHTS

Application

2010 CIVIC
2-DOOR
EX-L

Publications No.

All 42488

Issue Date

AUG 2009

PARTS LIST

P/N 08V31-SVA-110G

Right fog light



Left fog light



Switch harness

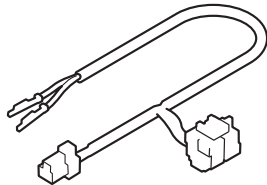

Fog light harness

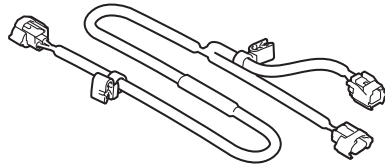

Sub harness

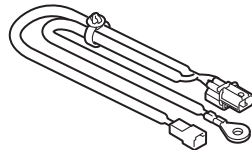

Combination light switch

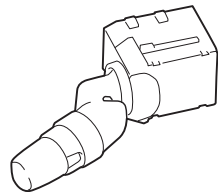

7 Wire ties

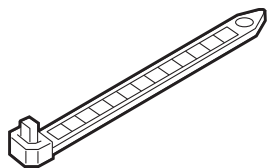

Clip

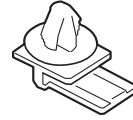

4 Spring nuts



4 Self-tapping screws



20A Fuse
(May not be used.)

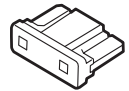

Relay

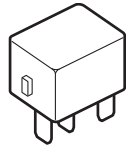

Ground bolt

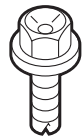

TOOLS AND SUPPLIES REQUIRED

Phillips screwdriver

Flat-tip screwdriver

Ratchet

10 mm and 12 mm Sockets

Gloves

Blanket

Diagonal cutters

5 mm Hex wrench

Shop towel

Masking tape

Illustration of Fog Lights Installed on the Vehicle

EX-L model

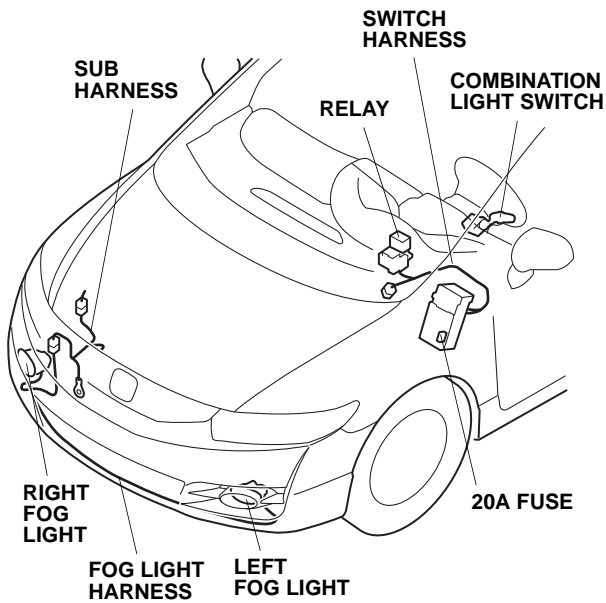

INSTALLATION

Customer Information: The information in this installation instruction is intended for use only by skilled technicians who have the proper tools, equipment, and training to correctly and safely add equipment to your vehicle. These procedures should not be attempted by "do-it-yourselfers."

1. Make sure you have the anti-theft codes for the audio system and navigation system (if equipped), then write down the radio presets.
2. Disconnect the negative cable from the battery.
3. Remove the radiator cover (two expansion clips and two clips).

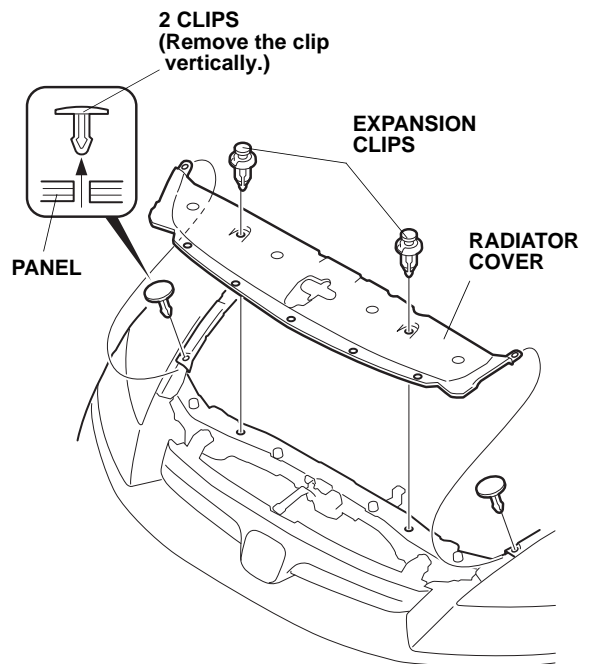

- With the help of an assistant, remove the front bumper (six clips, two self-tapping screws, two socket bolts and two bumper bolts). To prevent damage, set the front bumper on a blanket.

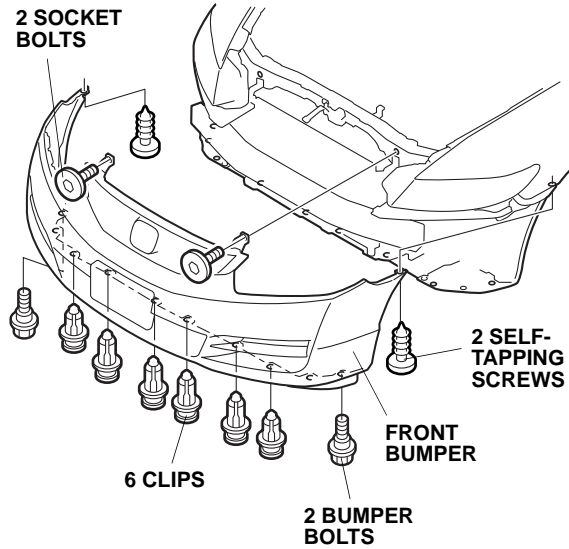

- Remove the left fog light cover (five pawls).

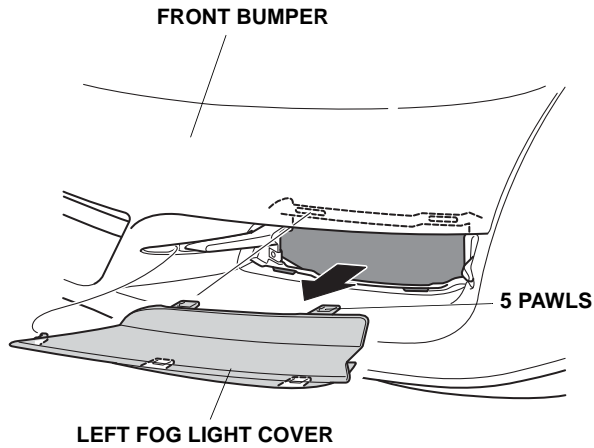

- Install the two spring nuts onto the front bumper.

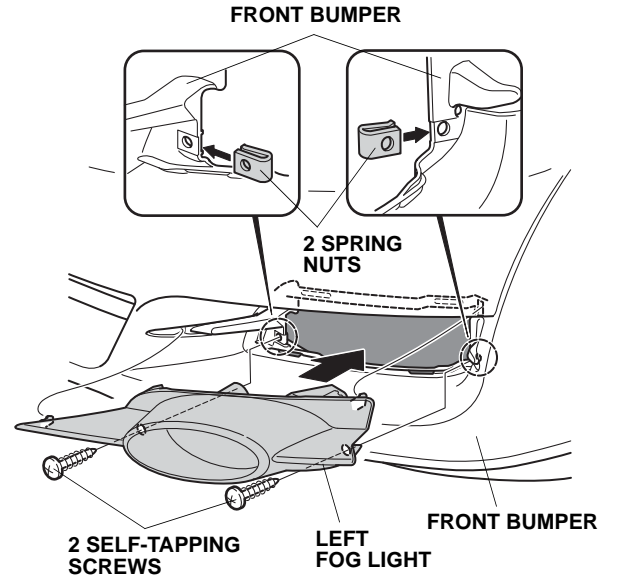

- Install the left fog light to the fog light cover opening, and secure it with two self-tapping screws.
- Repeat steps 5 through 7 on other side.
- Route the fog light harness 2-pin connector between the lower grille and the front bumper from the right side through the left side.

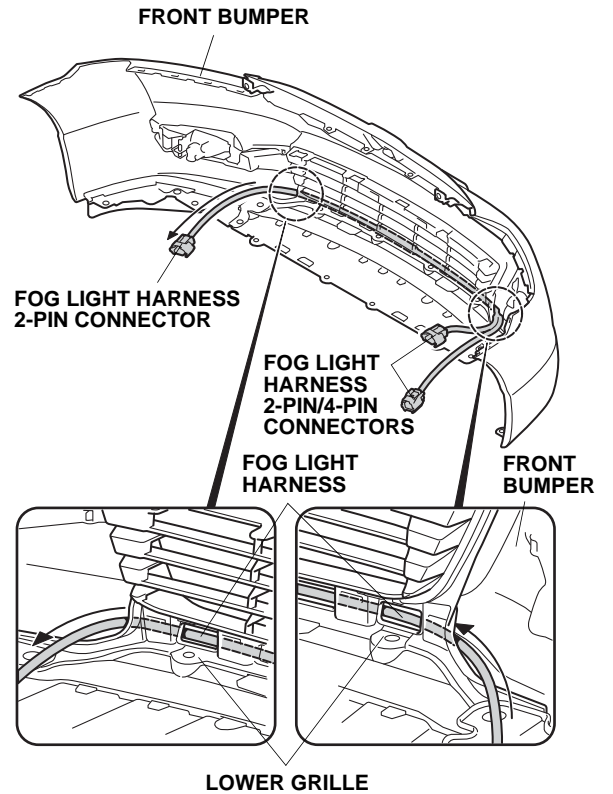

10. Plug the fog light harness 2-pin connector into the left fog light connector.

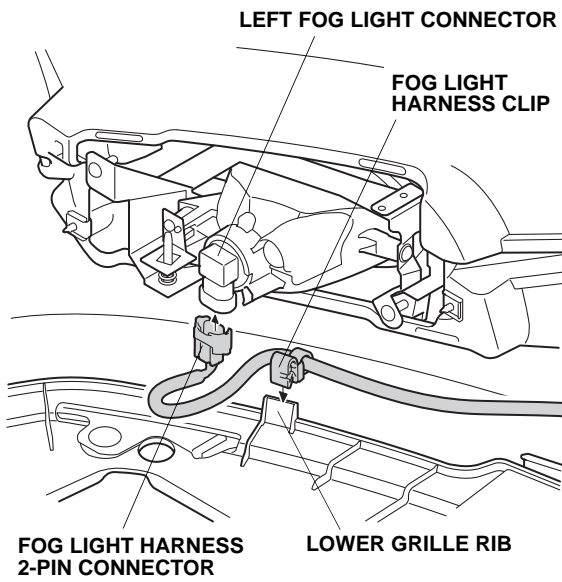

11. Install the fog light harness clip onto the lower grille rib.
12. Plug the fog light harness 2-pin connector into the right fog light connector.

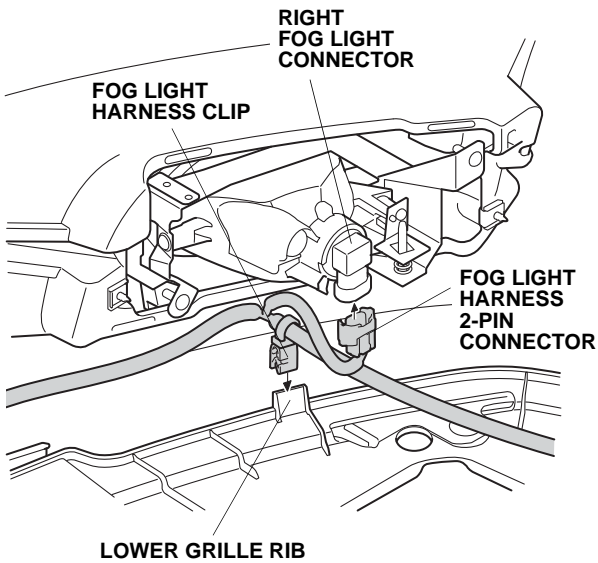

13. Install the fog light harness clip onto the lower grille rib.
14. Secure the fog light harness to each rib of the lower grille with one wire tie.

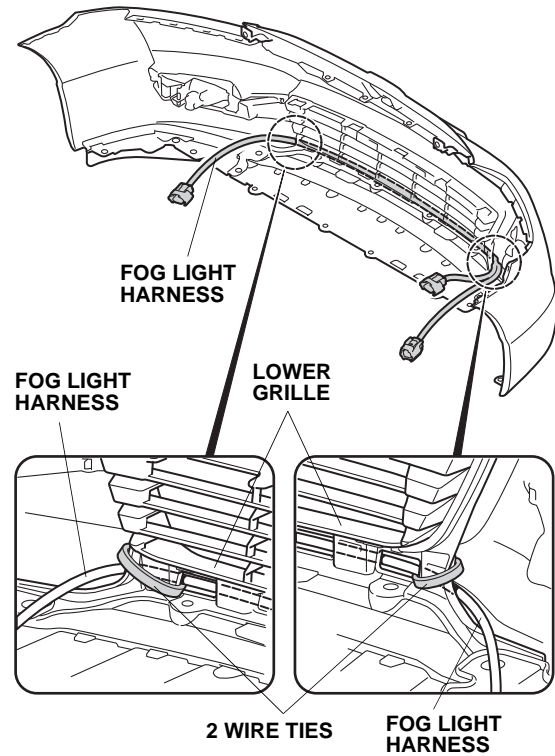

15. Remove three bolts from the washer tank.

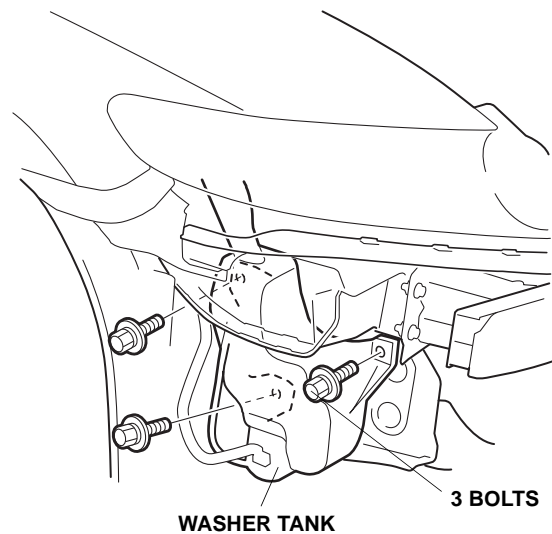

16. Locate the 1-pin connector blue-taped to the vehicle harness and remove the blue tape to free the 1-pin connector. Plug the vehicle 1-pin connector you just freed into the sub harness 1-pin connector.

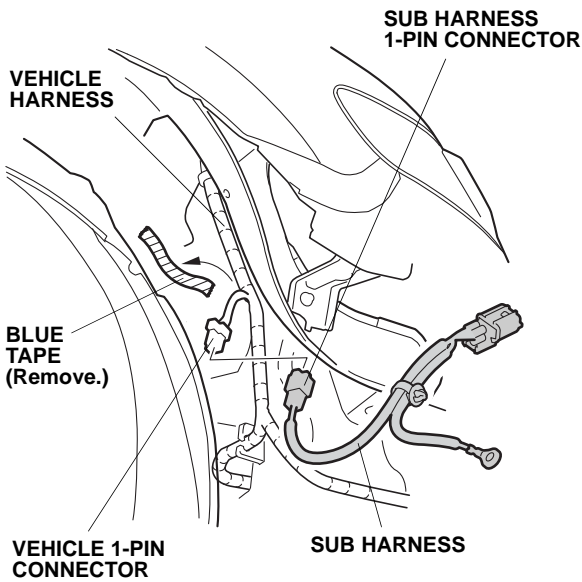

17. Route the sub harness between the washer tank and vehicle panel as shown.

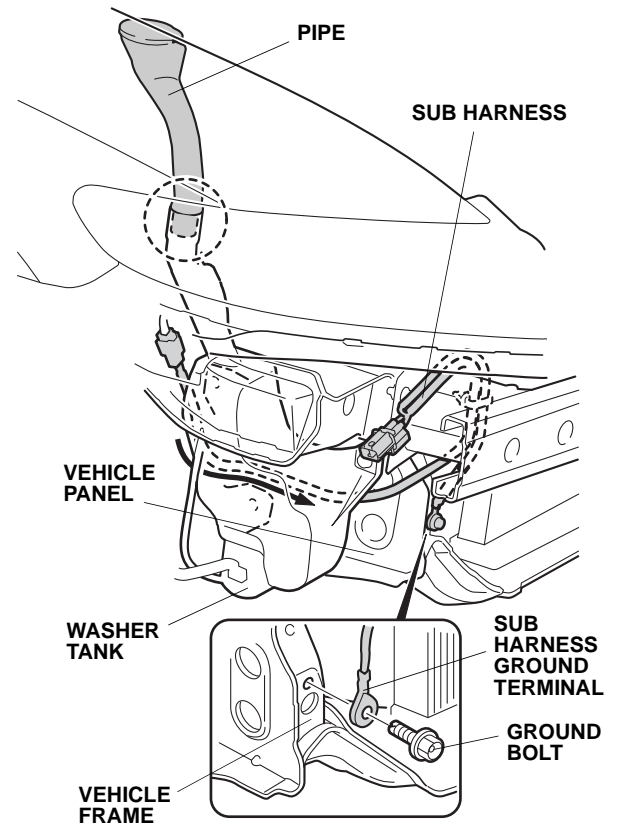

18. Secure the sub harness ground terminal to the vehicle frame using the ground bolt supplied.
19. Reinstall the washer tank. Check that the pipe of the washer tank is installed securely.

20. Secure the sub harness clip to the vehicle frame, and secure the sub harness to the vehicle harness using two wire ties.

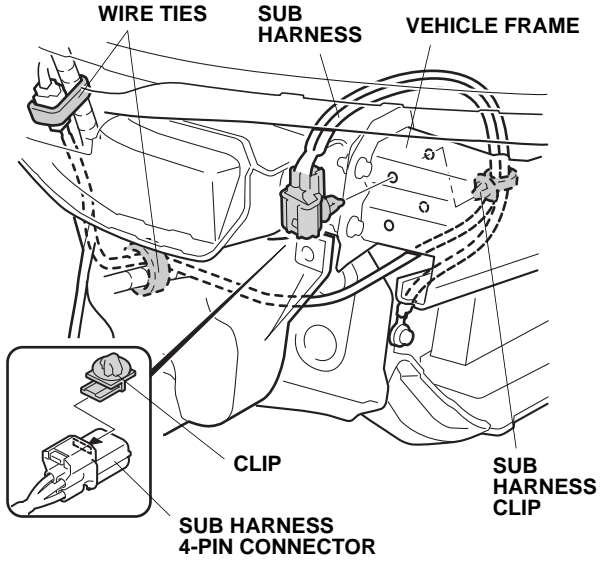

21. Slide the clip onto the sub harness 4-pin connector, and secure it to the vehicle frame.
 22. Plug the fog light harness 4-pin connector to the sub harness 4-pin connector.

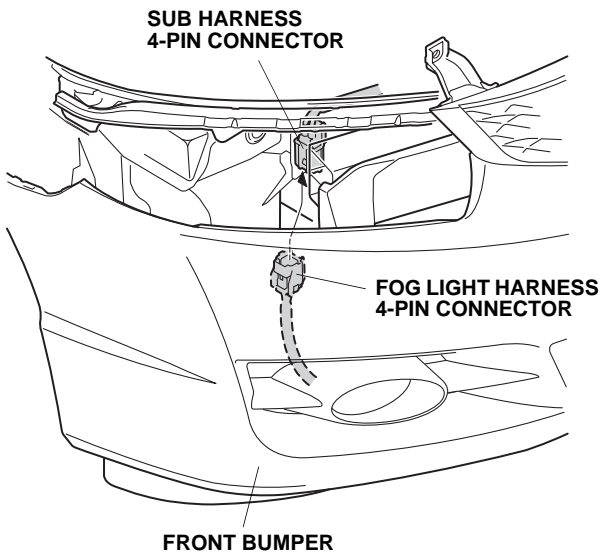

23. Reinstall the front bumper.

24. Remove the cover from the trunk lid/fuel fill door opener (six retaining tabs), and remove one self-tapping screw.

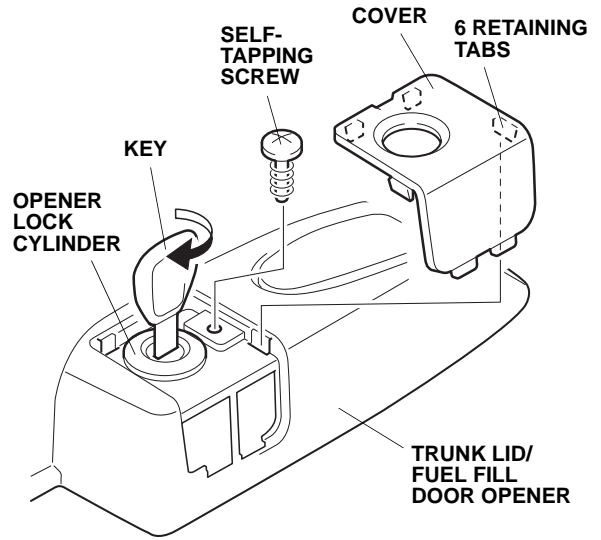

25. Using the key, unlock the opener.
 26. Raise the front side of the left front door sill trim (six clips, retaining tab and hook).

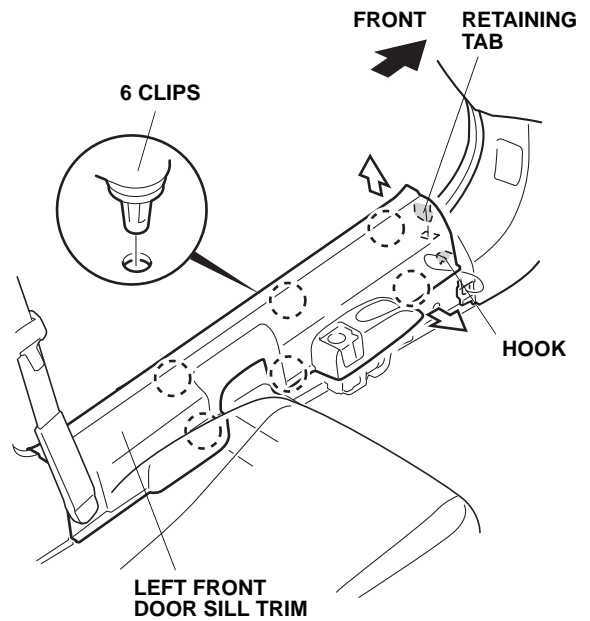

27. Remove the footrest.
- Using a hex wrench, remove the lower clip from the stud bolt.
 - Using a flat-tip screwdriver, remove the upper clip from the stud bolt.

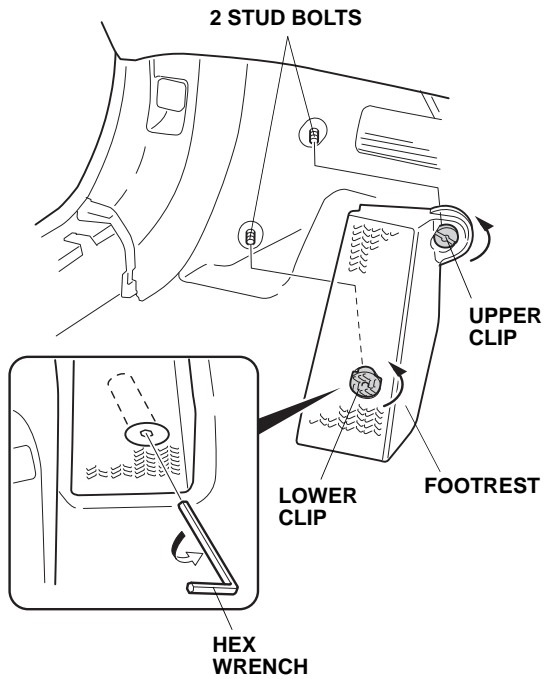

28. Pull away the weatherstrip from left kick panel and remove the left kick panel (two clips).

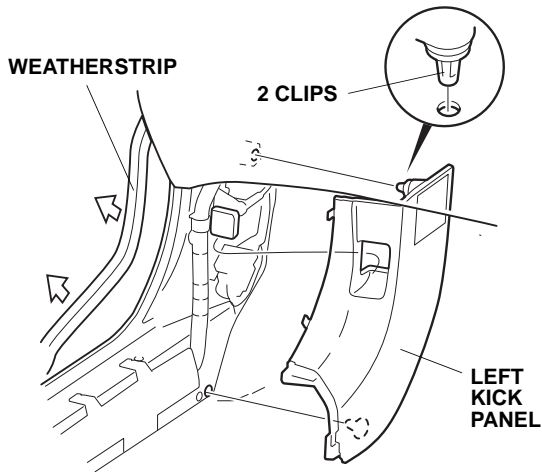

29. Remove the driver's dashboard under cover (turn the lock knob 90° counterclockwise, and release the two clips and pin).

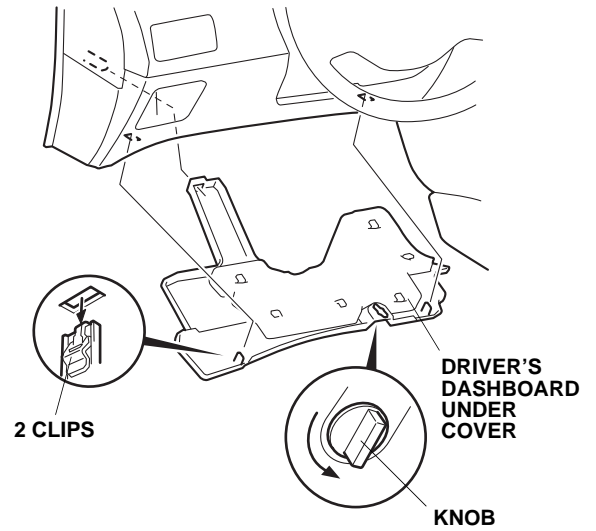

30. Remove the driver's dashboard lower cover (eight clips).

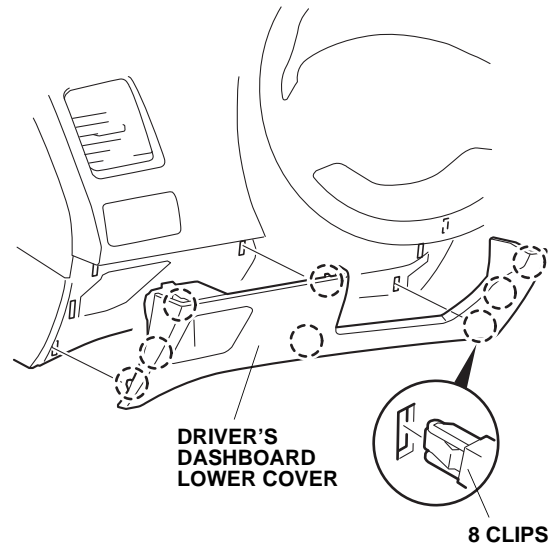

31. Lower the tilt lever, and pull the steering wheel toward you. Insert a flat-tip screwdriver along the guide of the column lower cover, and pry the retaining tab of the column upper cover.

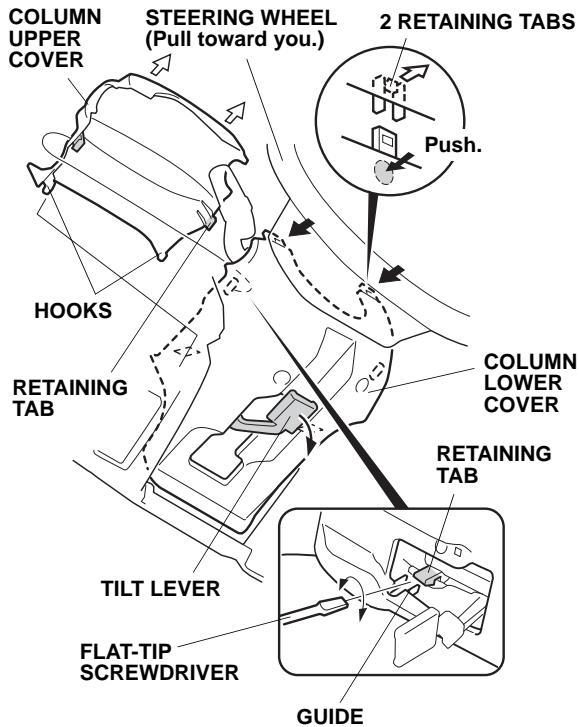

32. Push on the column lower cover in the area shown to separate the column upper cover from the column lower cover (three retaining tabs). Pull up to remove the column upper cover (two hooks).

33. Remove the column lower cover (two self-tapping screws and one screw).

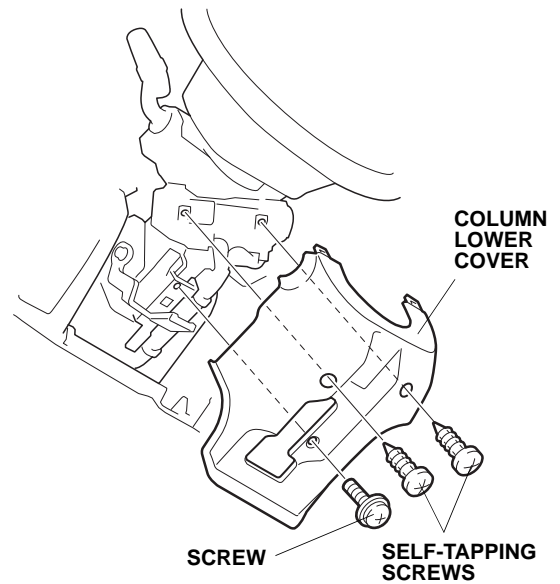

34. Remove the vehicle white 34-pin connector from the fuse box by pushing the retaining tab and raising the lock lever of the connector. Return the lock lever on the vehicle white 34-pin connector and remove the cover by sliding it.

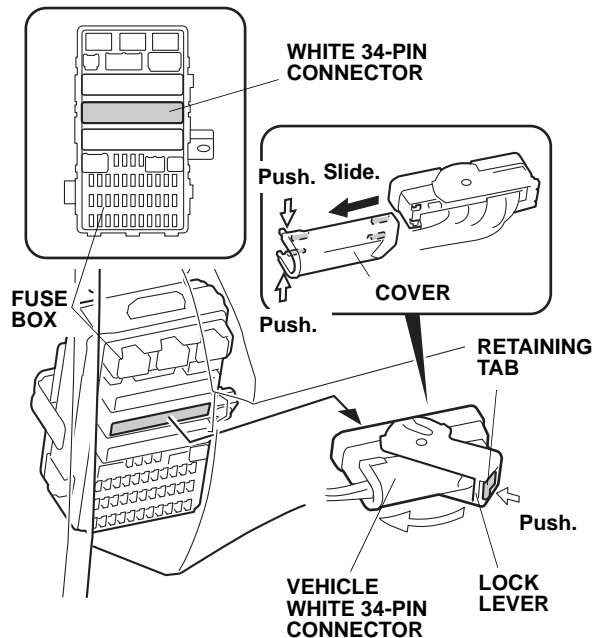

35. Insert the white/red and blue terminals from the switch harness into the vehicle white 34-pin connector.

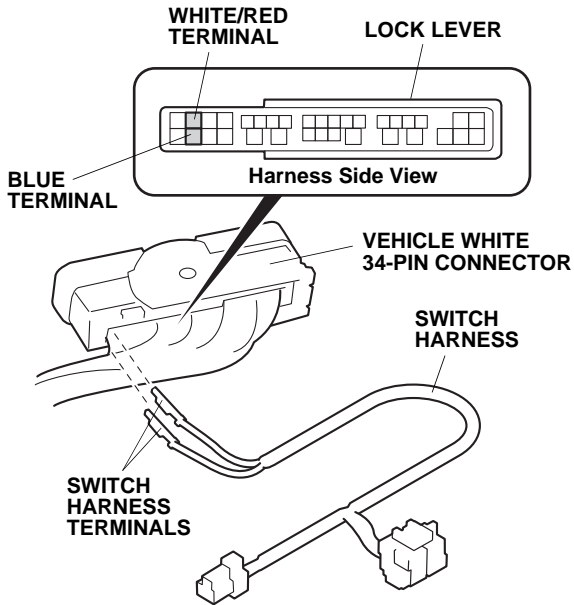

36. Reinstall the vehicle white 34-pin connector.
 37. Route the switch harness above the vehicle knee bolster.

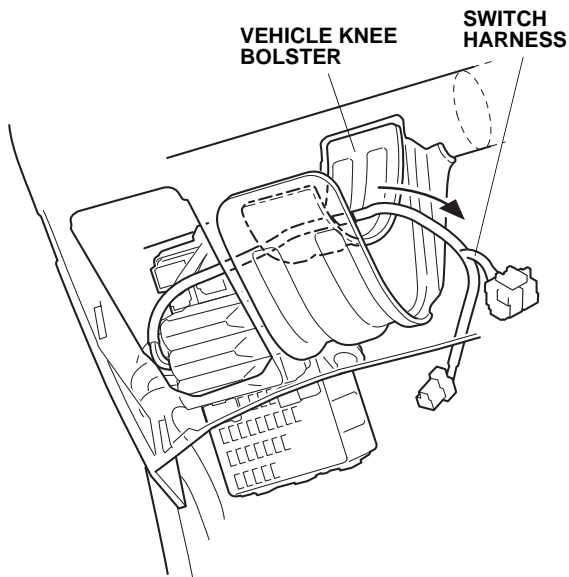

38. Plug the relay into the switch harness relay block, then slide the relay block onto the vehicle bracket stay.

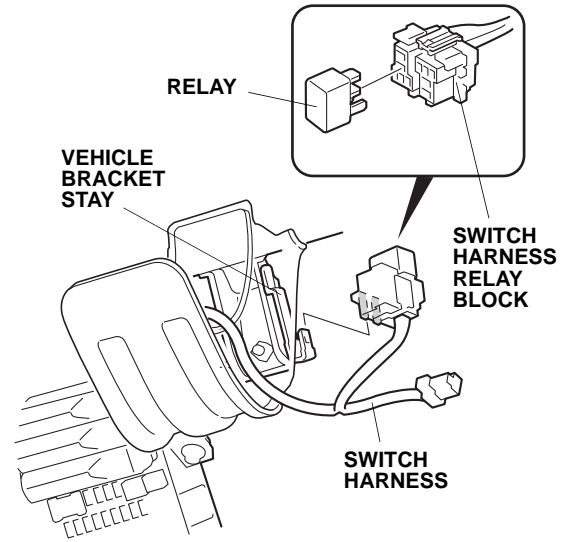

39. Locate the 1-pin connector blue-taped to the vehicle harness. Plug the switch harness 1-pin connector into the vehicle 1-pin connector.

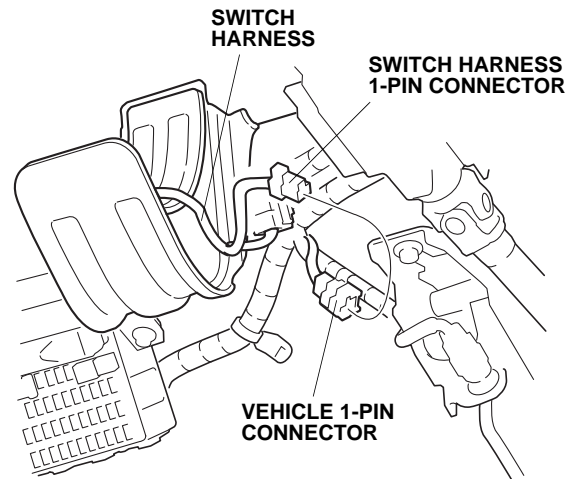

40. Secure the switch harness to the vehicle harness and vehicle knee bolster with three wire ties in the areas shown.

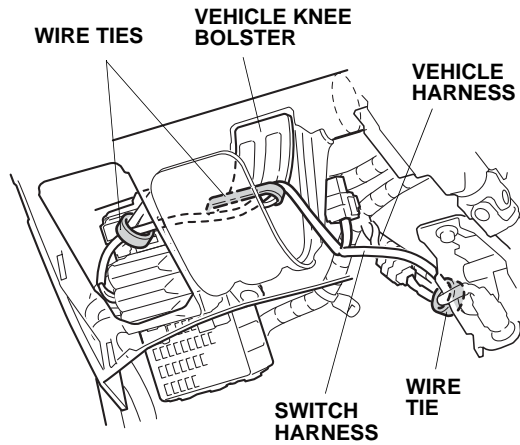

41. Lower the tilt lever and pull the steering wheel toward you.

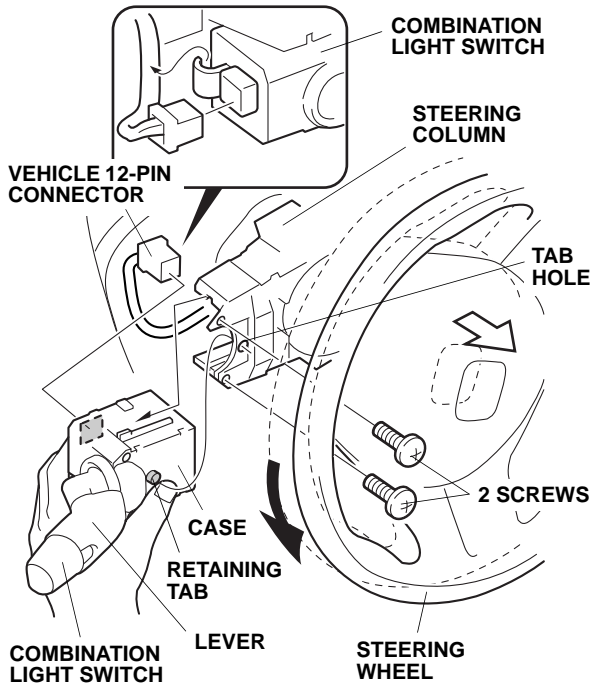

42. Turn the steering wheel 90° counterclockwise.
 43. Unplug the vehicle 12-pin connector from the combination light switch. Remove the two screws from the combination light switch. While pushing the retaining tab, slide the combination light switch out, and remove it from the steering column. Do not pull on the lever when removing the case. Do not damage the tab hole of the steering column.

44. Install the new combination light switch on the steering column using the two screws. Hold the case by hand, then install the new combination light switch to the steering column. Do not push on the lever when installing the case. Push in on the case and securely set the retaining tab into the tab hole.

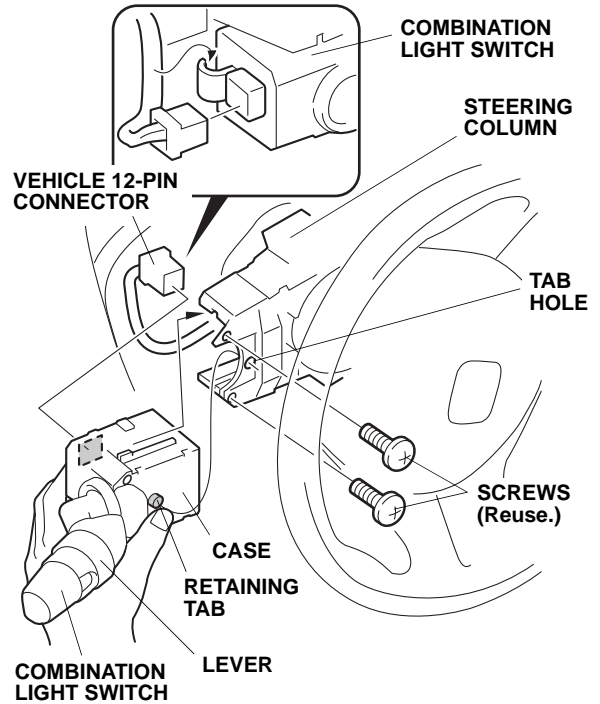

45. Plug the vehicle 12-pin connector to the new switch. Replace the vehicle harness.

46. Install the 20A fuse into the fuse box in the location shown. If a fuse is already installed, it is not necessary to install the 20A fuse.

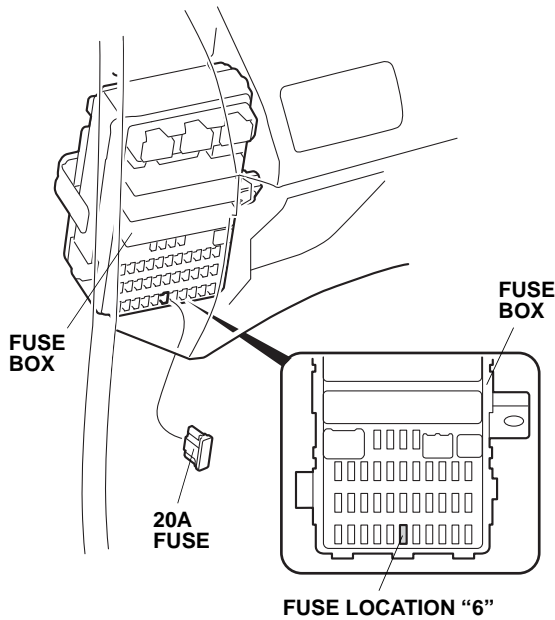

47. Check that all wire harnesses are routed properly and all connectors are plugged in.
48. Reinstall all removed parts.
49. Connect the negative cable to the battery and check operation of all lights and other electrical accessories.
50. Enter the anti-theft codes for the audio system and the navigation system (if equipped), and reset the radio station presets.
51. Reset the clock on vehicles without navigation.

USE AND CARE

How to Operate Fog Lights

- Turn the light switch to the “☁” position (headlights on low beam).
- Press the fog light switch (indicator is on).

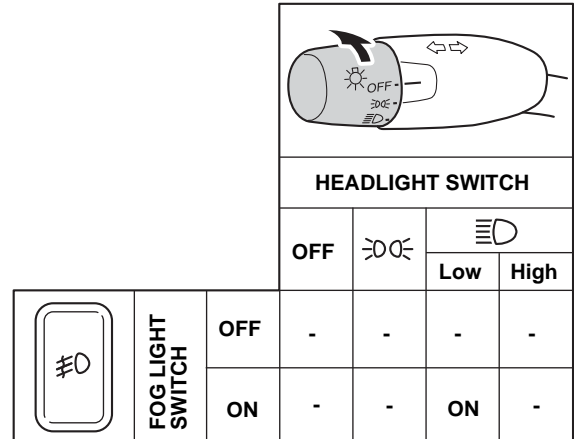

NOTE: The fog light lenses can cloud when the outside temperature is cold; this is normal and should go away in warm weather.

Adjusting the Aim

1. Adjust the vertical aiming according to local laws and regulations. To adjust, turn the adjusting screw in or out until the correct angle is obtained.

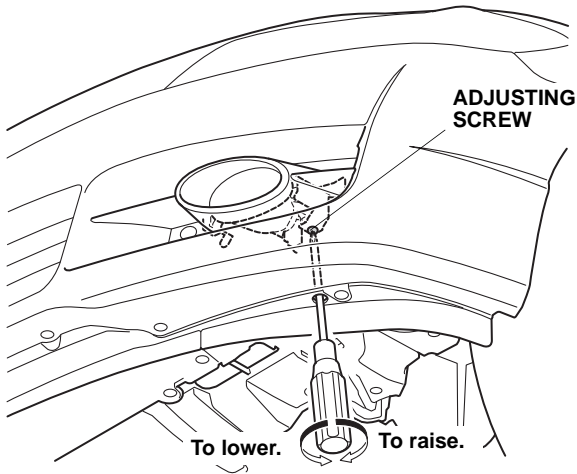

2. Repeat on the right side.

BULB REPLACEMENT

1. Remove the two self-tapping screws, and pull the left fog light out toward you.

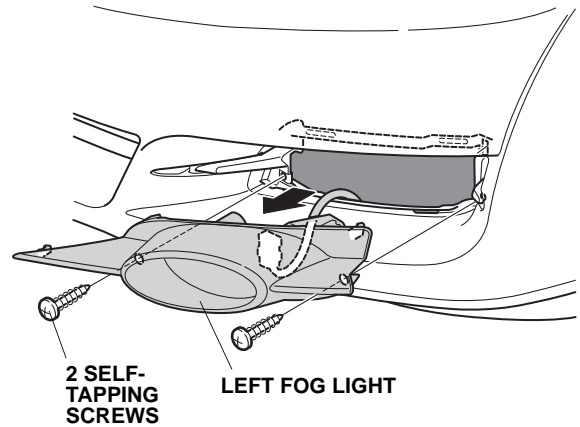

2. Unplug the connector from the left fog light while pushing the retaining tab in on the connector.

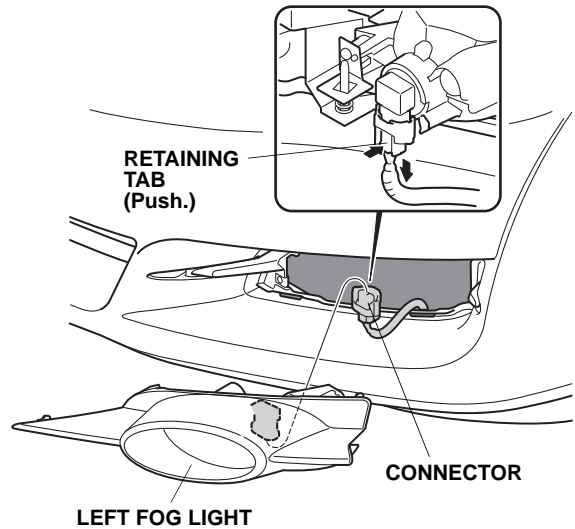

3. Remove the bulb from the left fog light by turning it counter clockwise.

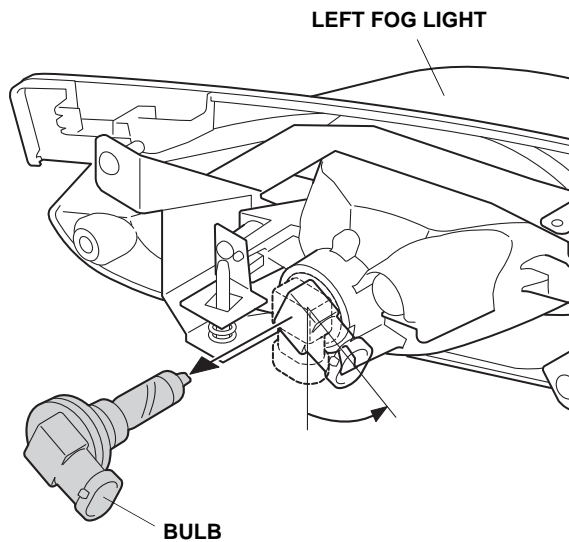

4. Install a new bulb on the left fog light by turning it clockwise until it stops.
 - Take extreme care when replacing the fog light bulb to avoid damaging the lenses or finished surfaces of the body.
 - Use only a Honda Genuine halogen light bulb of specified wattage.
Rating: 12V 55W H11 Halogen Light Bulb P/N33165-S5A-003
 - Do not touch the bulb. Oily or greasy substances on the bulb can shorten its service life due to the heat produced when the bulb is turned on. If the bulb is accidentally touched, wipe it clean with a soft cloth that has been dampened with a denatured alcohol or a mild detergent solution.
 - When installing the new bulb, align the cutout on the fog light with the tab on the new bulb and turn the new bulb in completely. If not properly aligned, the fog light may blind oncoming driver's.

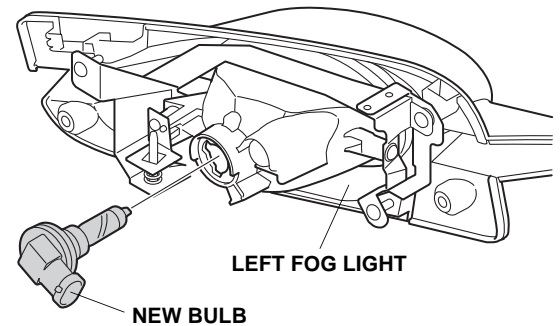
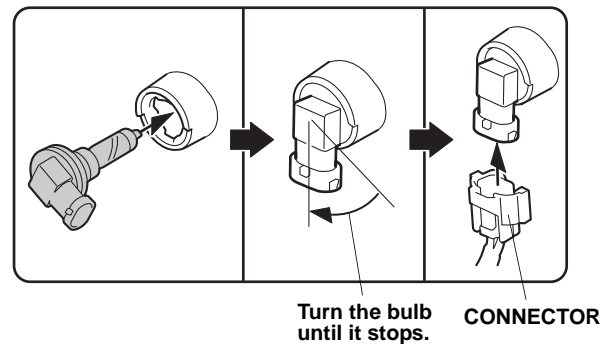

5. Plug the connector to the bulb.
6. Install the left fog light in the inverse order of removal.
7. After the replacement, check that the bulb comes on properly. Adjust the fog light aiming adjustment as necessary.