



# INSTALLATION INSTRUCTIONS

Accessory

**CD CHANGER ATTACHMENT KIT (TRUNK MOUNT)**

Application

**2009 S2000**

Publications No.

**All 40446**

Issue Date

**AUG 2008**

## PARTS LIST

**CD Changer Attachment Kit:  
P/N 08B26-S2A-100A**

CD Changer bracket

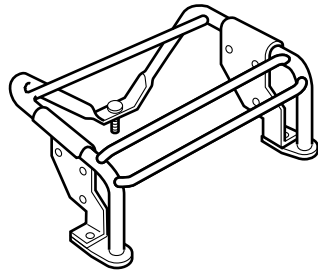

Bus cable

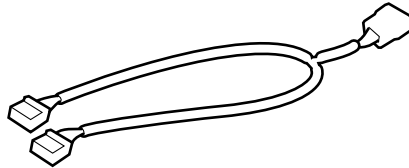

Butyl washer



7 Wire ties

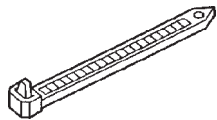

2 Cushion tapes

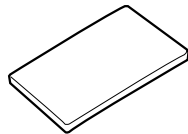

2 Jack nut



Special tool



2 Flange bolts



Nut



Plain washer



Template

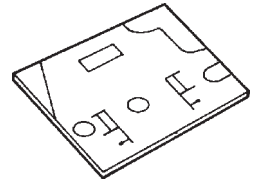

CD Changer cover

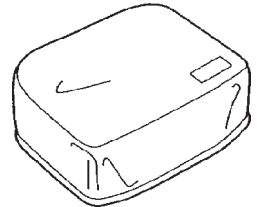

EPT sealer

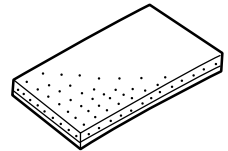

6 Washer-screws, 4 x 8 mm



Wire tie with clip  
(for XM Radio-equipped models only)

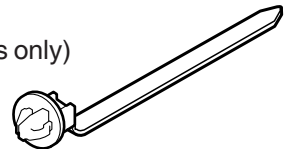

**CD Changer (sold separately):  
P/N 08A26-5E1-100**

CD changer

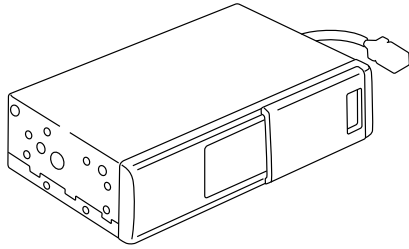

Side bracket

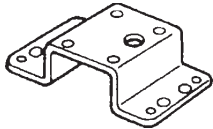

8-Disc CD magazine

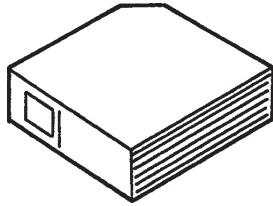

8 Washer-screws, 4 x 6 mm  
(4 Not used)



Accessory user's  
information manual

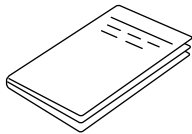

**TOOLS AND SUPPLIES REQUIRED**

- Phillips screwdriver
- Small flat-tip screwdriver
- 10 mm Socket
- Ratchet
- 10 mm Combination wrench
- Diagonal cutters
- Utility knife
- Tape measure
- Masking tape
- Felt-tip pen
- Drill
- 7 mm Drill bit
- 25 mm Hole saw
- Touch-up paint
- Awl
- Shop towel
- File
- Eye protection (face shield, safety goggles, etc.)

***Illustration of the CD Changer installed on the Vehicle***

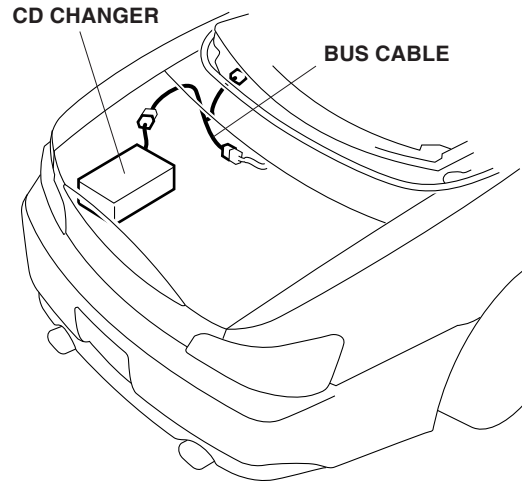

**INSTALLATION**

**Customer Information:** The information in this Installation Instruction is intended for use only by skilled technicians who have the proper tools, equipment, and training to correctly and safely add equipment to your vehicle. These procedures should not be attempted by “do-it-yourselfers.”

1. Make sure you have the anti-theft code for the radio, then write down the radio station presets.
2. Disconnect the negative cable from the battery.

- Open the trunk lid, and remove the tool tray. Remove all 12 clips and the two that secure the spare tire panel, and remove the panel.

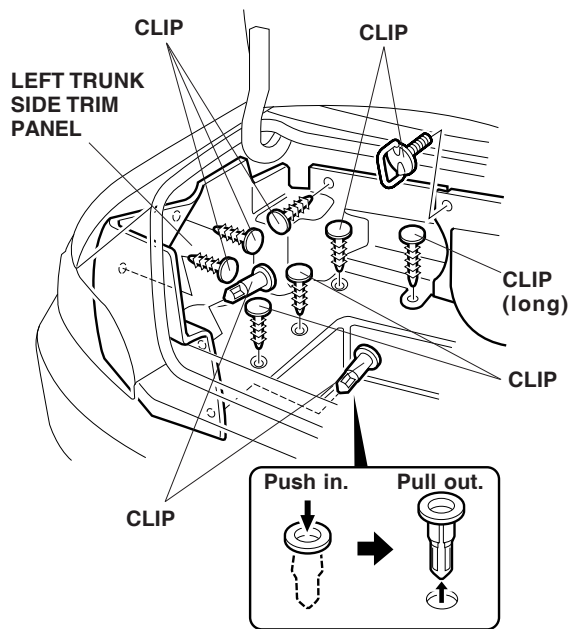

- Using a tape measure and a felt-tip pen, measure and mark the left trunk side trim panel. Cut out the marked area from the panel with a utility knife.

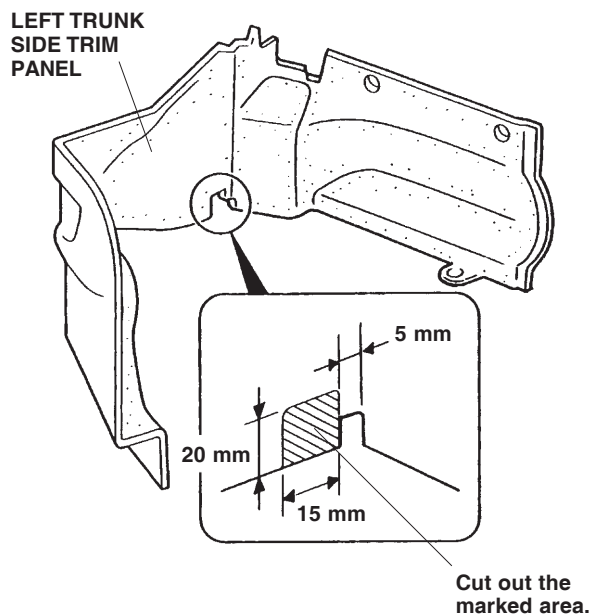

- Get the template. Using a utility knife, cut out all the round holes, rectangular holes, and slits in the template.

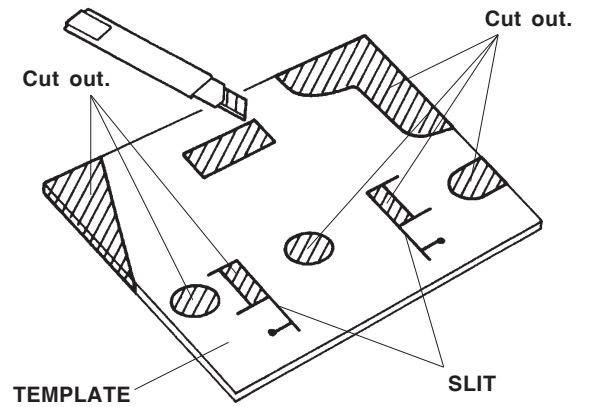

- Position the template by aligning the round holes in the template with the clip holes, then tape the template in place to the left of the trunk floor trim panel. Mark the edges of the rectangular holes and down along the slit lines on the panel with a felt-tip pen. Make the round marks, and remove the template.

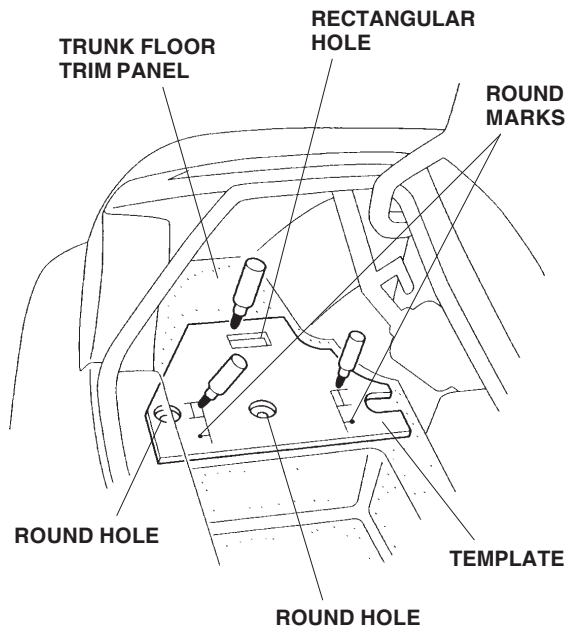

7. While wearing eye protection, lift up the trunk floor trim panel, and drill a 25 mm hole through each of the two marks you made in the panel. Drill the 25 mm holes only through the trunk floor trim panel and not through the trunk floor panel.

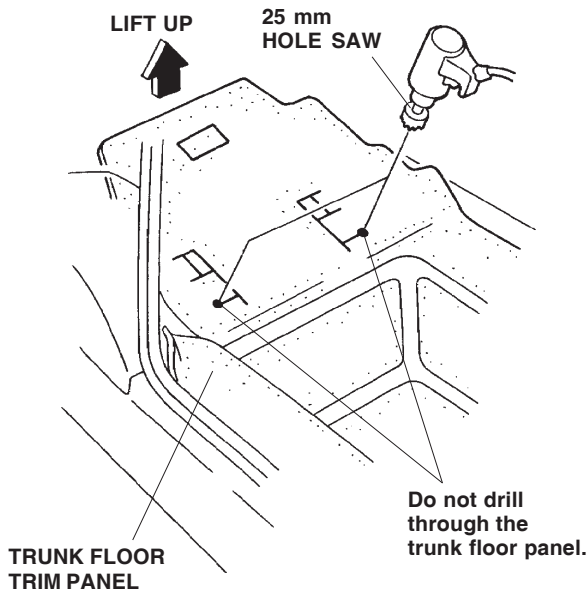

8. Using a utility knife, cut out the three marked areas from the floor carpet.

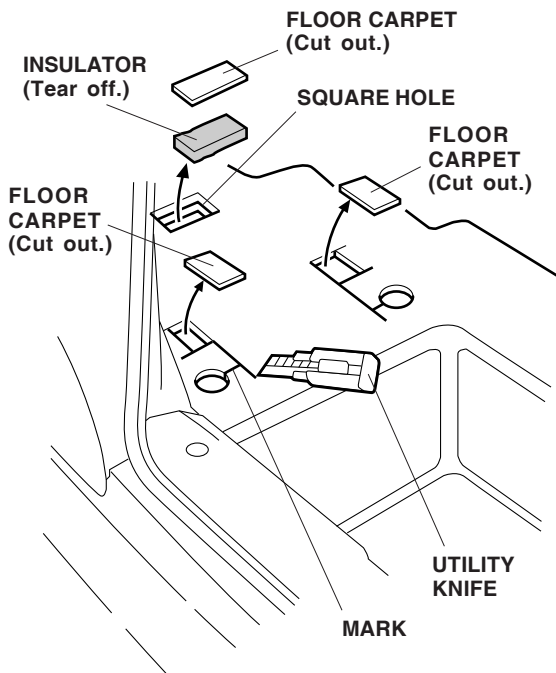

9. While wearing eye protection, drill a 7 mm hole through the recess on the floor panel. First drill with a 3 mm bit, and finish with a 7 mm bit.

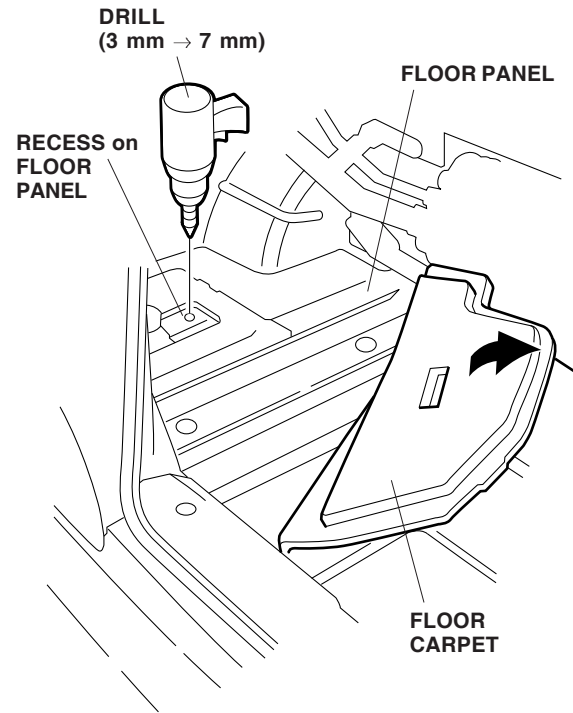

10. Remove the two grommets from the floor panel, and insert the jack nuts into the holes.

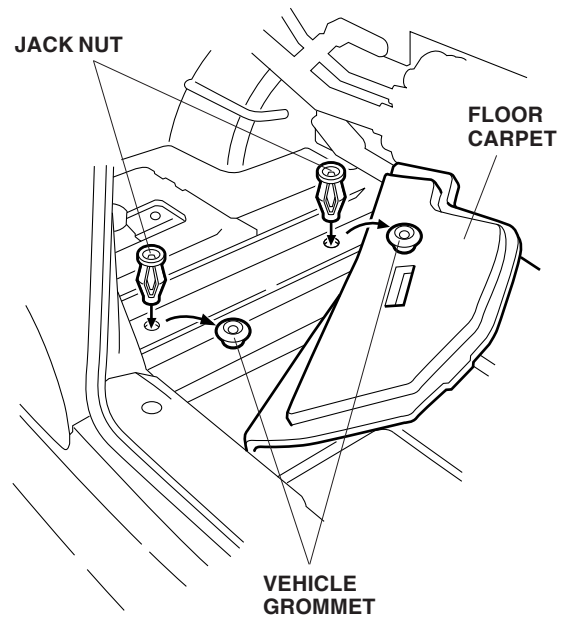

11. Thread a flange-bolt into each of the jack nuts with the special tool provided:

- Bend the tool as shown before applying it to the flange-bolt.
- While holding the jack nut with the tool, tighten the flange-bolt to collapse the jack nut.
- Remove the flange-bolt.

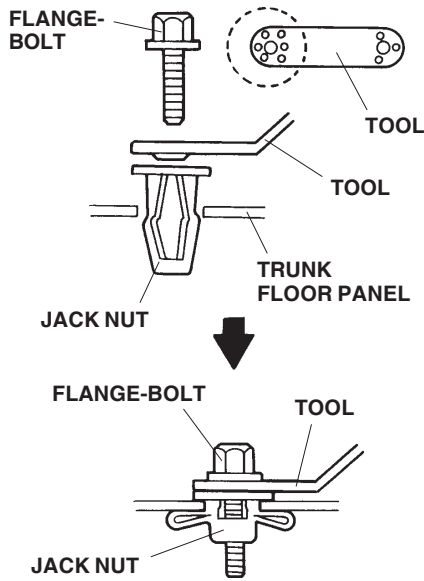

## Installing the CD Changer

12. Visually check the position of the spring adjusting slots on both sides of the CD changer. If both of the spring adjusting slots are not in the horizontal (H) position, move the slots to the horizontal position using a small flat-tip screwdriver.

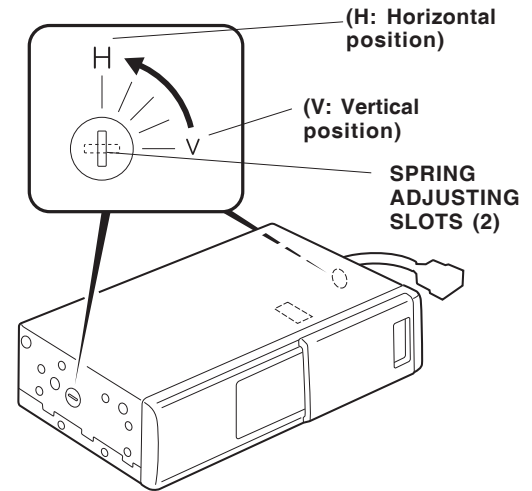

13. Position the side bracket included in the CD changer kit on the CD changer, and install four of the 4 x 6 mm washer-screws also provided with the CD changer kit.

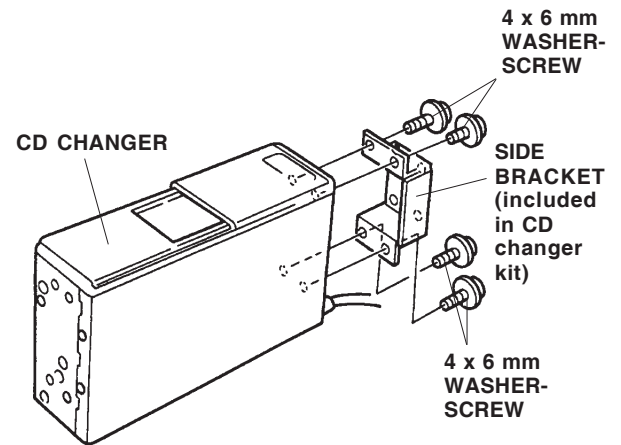

- Position the CD changer bracket on the CD changer, and secure the bracket with the six 4 x 8 mm washer-screws.

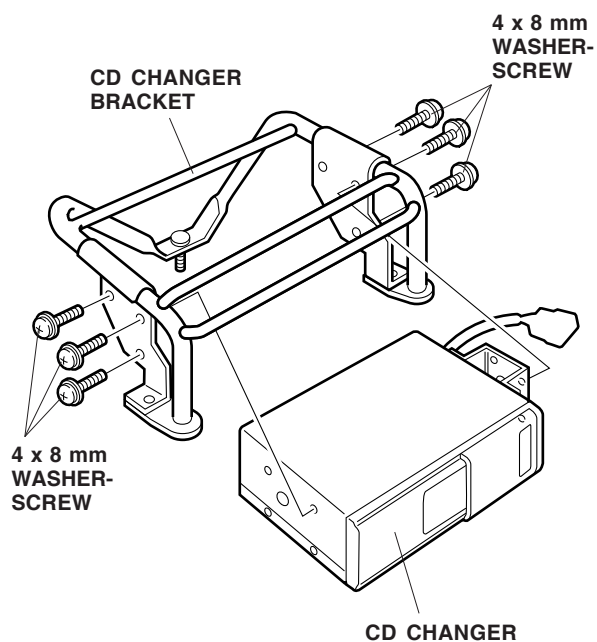

- Position the CD changer and bracket assembly on the trunk floor panel, and install the two flange bolts from the inside. Install a butyl washer, a plain washer, and a nut on the end of the one stud bolt from the underside, as shown.

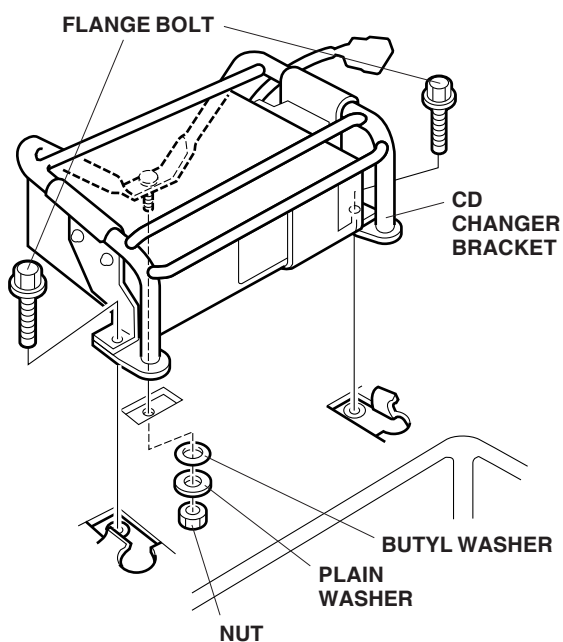

## Routing the Bus Cable

*NOTE: If the vehicle you're working on is equipped with XM radio, go to step 27; otherwise, continue with step 16.*

- Inside the trunk, pull out the vehicle subharness from the fuel tank by cutting the vehicle wire tie with clip. Take care not damage the vehicle harness when cutting the wire tie.

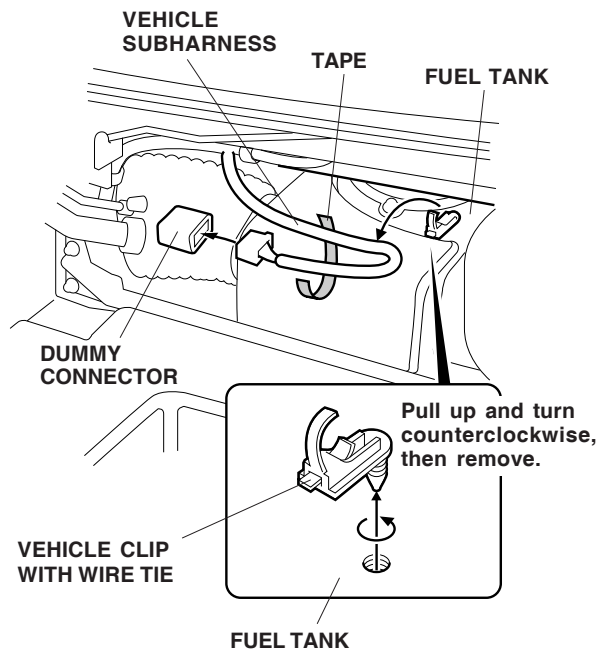

- Remove the vehicle clip with wire tie from the fuel tank.
- Remove the tape from the vehicle subharness to free the harness. Remove the dummy connector from the subharness connector.

19. Connect the bus cable 14-pin connector to the vehicle subharness 14-pin connector.

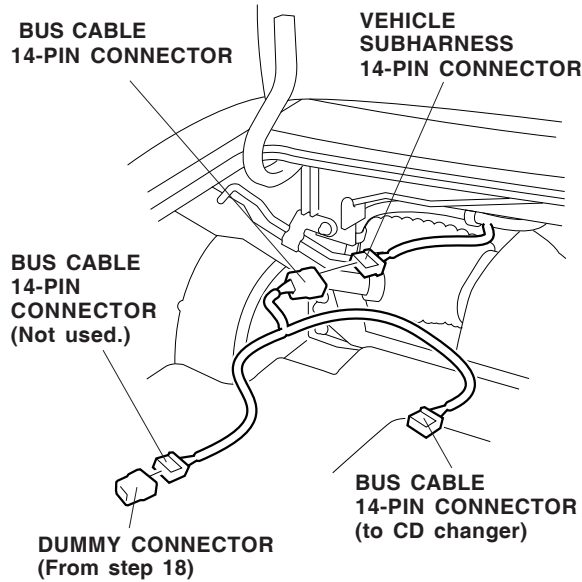

20. Install the dummy connector (from step 18) to the bus cable 14-pin connector.

21. Route one end of the bus cable to the left and along the vehicle harness, and plug the 14-pin connector into the CD changer 14-pin connector. Attach the 14-pin connector and the CD changer bus cable to the vehicle panel with the two cushion tapes.

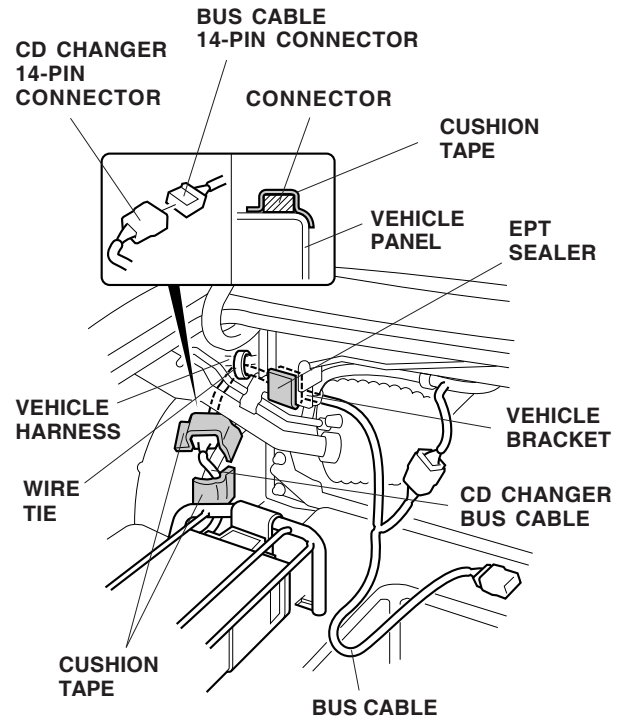

22. Locate the vehicle bracket bolt. Wrap the EPT sealer around the vehicle bracket to prevent the bus cable from interfering with the bracket bolt.
23. Secure the bus cable to the vehicle harness on the left of the vehicle bracket with one wire tie.

24. Route the excess bus cable with 14-pin connector up along the vehicle harness.

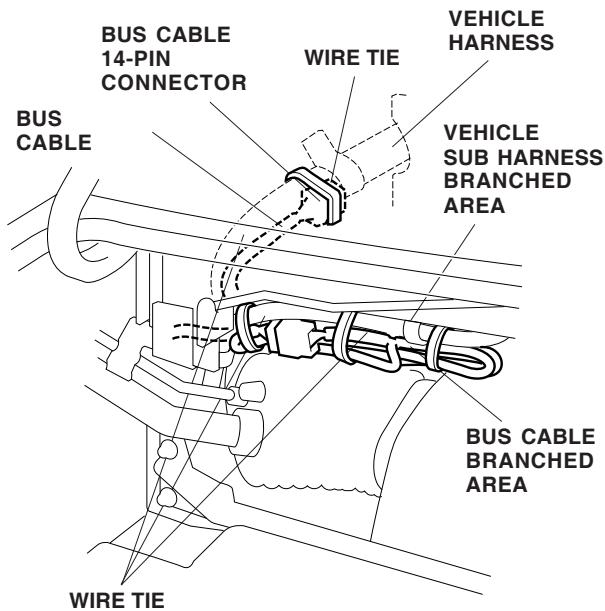

25. At the branched area of the bus cable and sub harness, loop the excess harness, and secure the harnesses to the vehicle harness with the four wire ties.
26. Secure the bus cable 14-pin connector, and the bus cable to the vehicle harness with two wire ties.

*NOTE: If the vehicle is not equipped with XM radio go to step 37; otherwise, continue with step 27.*

27. Loosen the two bolts that fasten the XM radio to the vehicle.

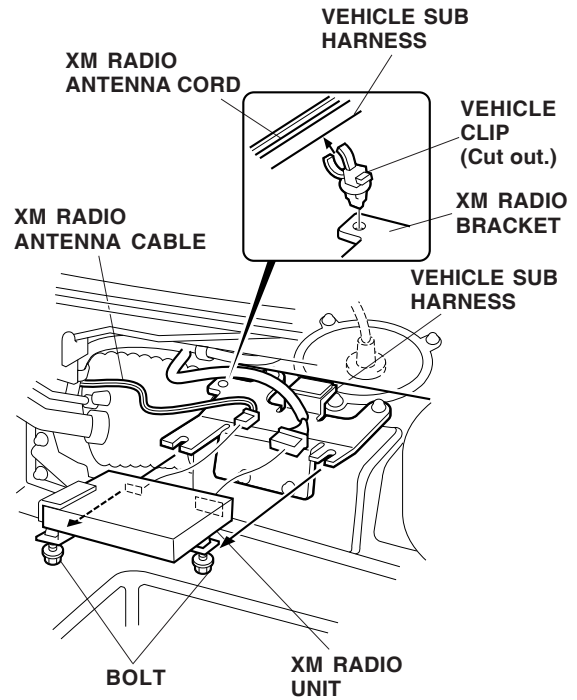

28. Pull the XM radio out toward you, and release the vehicle clip that attaches the vehicle subharness and XM radio antenna cable away from the XM radio bracket. Cut and remove the clip from the vehicle subharness and XM radio antenna.
29. Unplug the vehicle subharness and the XM radio antenna from the rear of the XM radio unit.



30. Connect the 14-pin connector at the branch of the bus cable into the vehicle subharness 14-pin connector, and plug the 14-pin connector at the end of the bus cable into the XM radio unit.

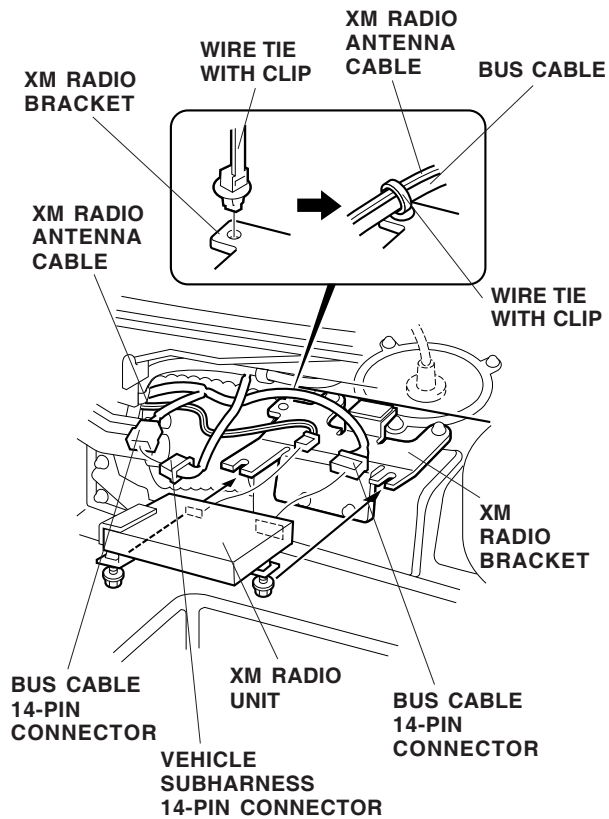

31. Plug the XM radio antenna cable connector into the rear of the XM radio unit. Secure the XM radio antenna cable and the bus cable to the bracket with one wire tie with clip.
32. Reinstall the XM radio unit.

33. Route one end of the bus cable to the left and along the vehicle harness, and plug the bus cable 14-pin connector into the CD changer 14-pin connector. Attach the 14-pin connector and the CD changer bus cable to the vehicle panel with two cushion tapes.

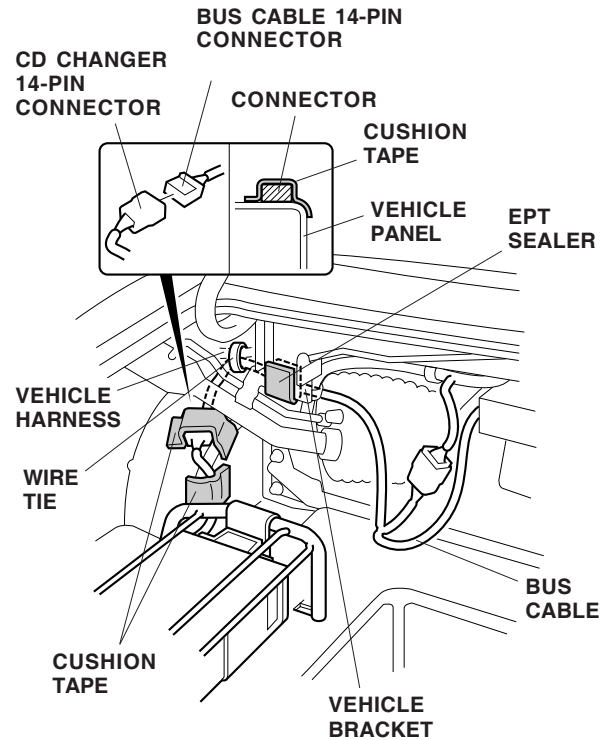

34. Locate the vehicle bracket bolt. Wrap the EPT sealer around the vehicle bracket to prevent the bus cable from interfering with the bracket bolt.
35. Secure the bus cable to the vehicle harness on the left of the vehicle bracket with one wire tie.

36. At the branched areas of the bus cable and the subharness, loop the excess harness and secure the harnesses to the vehicle harness with three wire ties.

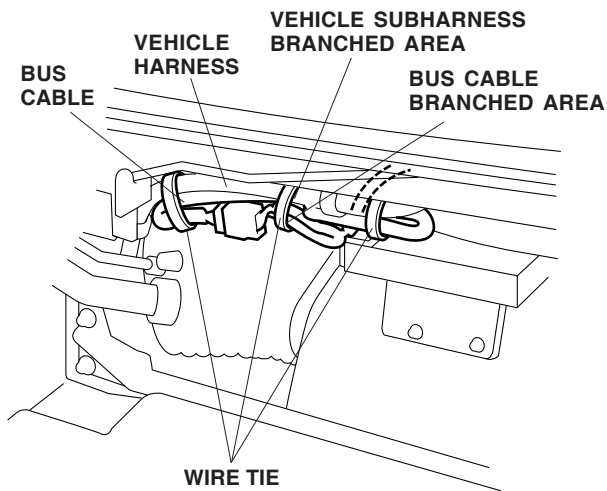

37. Place the CD changer cover over the CD changer.

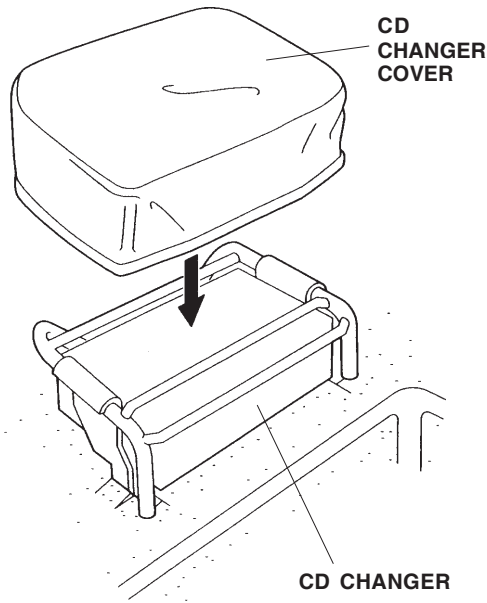

38. Reinstall all removed parts.
39. Check that all wire harnesses are routed properly and all connectors are plugged in.
40. Reconnect the negative cable to the battery.
41. Enter the customer's radio anti-theft code, and reset the radio station presets.
42. Reset the clock.
43. Check operation of the CD changer/cassette player according to the owner's manual provided.

**NOTE:** Whenever the battery is disconnected, the driver's window AUTO function is disabled.

44. Start the engine. Push down on the driver's window switch until the window is fully open.
45. Pull up on the driver's window switch to close the window completely, then hold the switch for 2 seconds or more.
46. Lower and raise the driver's window to check operation of the driver's window AUTO function.
47. Do the ECM/PCM idle learn procedure.
  - Make sure all electrical items are turned off.
  - Start the engine. Hold the engine speed at 3,000 rpm with no load (in Park or Neutral) until the radiator fan comes on.
  - Let the engine idle for about 5 minutes with the throttle fully closed and with all electrical items off.

**NOTE:** When the radiator fan comes on, do not include its running time in the 5 minutes.