

PARTS LIST**Engine Block Heater kit
P/N 08T44-SNA-101**

Engine block heater

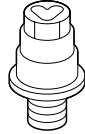

Aluminum washer



Heater harness

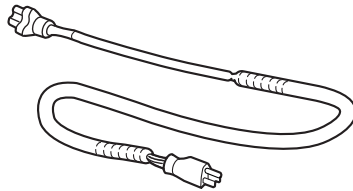

Protective cap

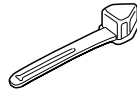
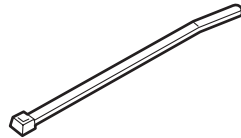
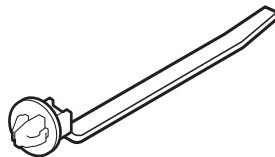
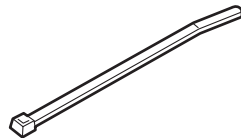
12 Black wire ties
(6 not used)7 Wire ties with clip
(3 not used)5 White wire ties
(Not used)**Engine Block Heater Bracket kit
P/N 08T44-TK6-100**

Bracket

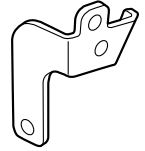

Washer-bolt

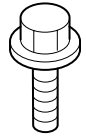
**TOOLS AND SUPPLIES REQUIRED**

Ratchet

10 mm, 19 mm, and 24 mm Sockets

100 mm (4 in.) Extension

Torque wrench

Diagonal cutters

Heavy gloves

Drain pan

Tape measure

White marker

Honda All Season Antifreeze/Coolant Type 2

Fender cover

NOTE: Using an extension longer than 100 mm (4 in.) will give you an incorrect torque reading.

Illustration of the Engine Block Heater Installed on the Vehicle

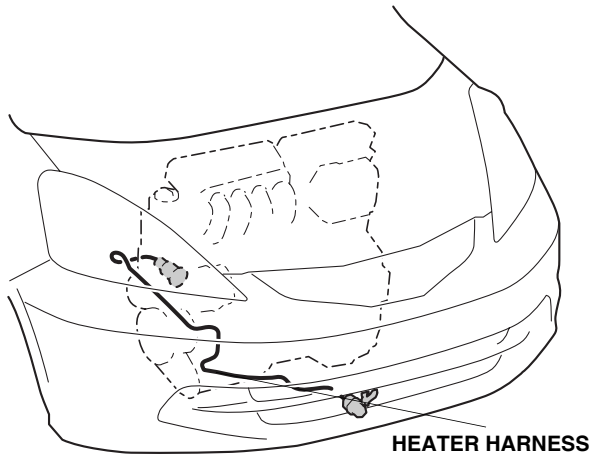

INSTALLATION

NOTE:

- Always use Honda All Season Antifreeze/Coolant Type 2. Using a non-Honda coolant can result in corrosion, causing the cooling system to malfunction or fail.
- To avoid burning out the element, do not operate the engine block heater before it is installed in the vehicle and before you add coolant.

Customer Information: The information in this installation instruction is intended for use only by skilled technicians who have the proper tools, equipment, and training to correctly and safely add equipment to your vehicle. These procedures should not be attempted by “do-it-yourselfers.”

1. Make sure you have the anti-theft code for the audio unit and navigation system (if equipped), then write down the radio station presets.
2. Disconnect the negative cable from the battery.
3. Allow the engine and all cooling system components to cool down.

4. Place a clean drain pan under the radiator drain plug, then remove the drain plug from the bottom of the radiator to drain the coolant. Remove the radiator cap to increase the flow.

NOTICE

Radiator coolant will damage paint. Quickly rinse any spilled coolant from painted surfaces.

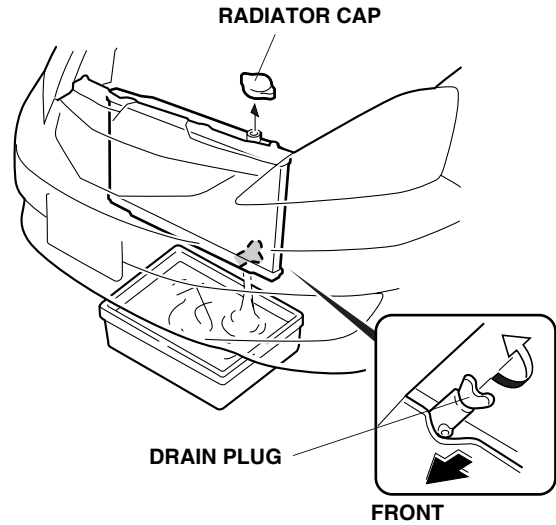

5. With the vehicle on a lift, remove the engine splash guard (one screw and three clips).

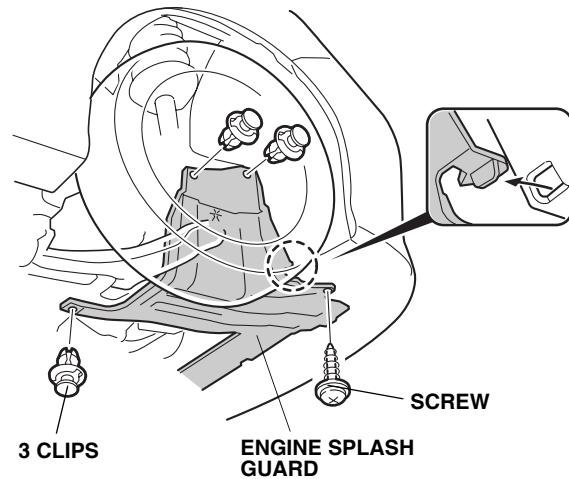

- Using a 19 mm socket, remove the drain bolt and washer from the engine block. Coolant remaining in the engine jackets will flow out the hole when the plug is removed. Retain the plug; It will be used if the engine block heater is removed.

NOTE: Use a new washer if the drain bolt is reinstalled.

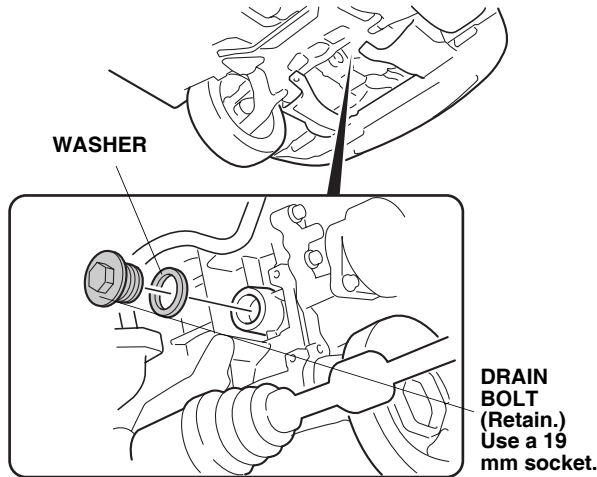

- Install the engine block heater with aluminum washer into the engine block using a 24 mm socket with a 100 mm (4 in.) extension. Torque the engine block heater to 60 N·m (44 lbf-ft). Using an extension longer than 100 mm (4 in.) will give you an incorrect torque reading.

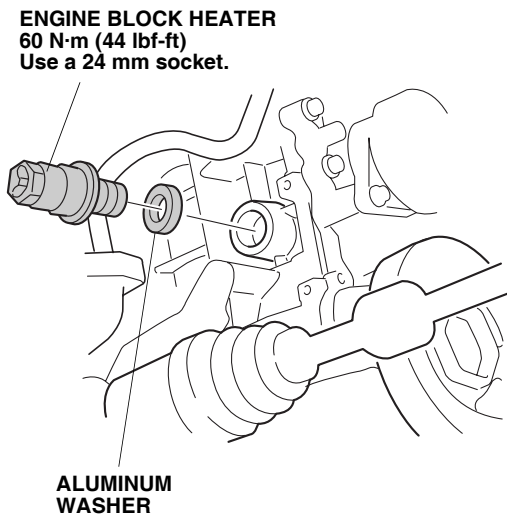

- Measure and mark the heater harness at the point shown. Install a wire tie with clip to the heater harness at each of the measurements shown.

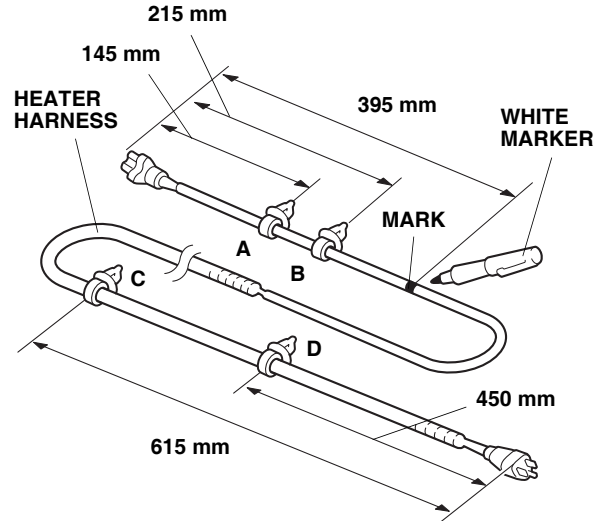

- Plug the heater harness connector into the engine block heater. Temporarily place the entire heater harness on top of the engine.

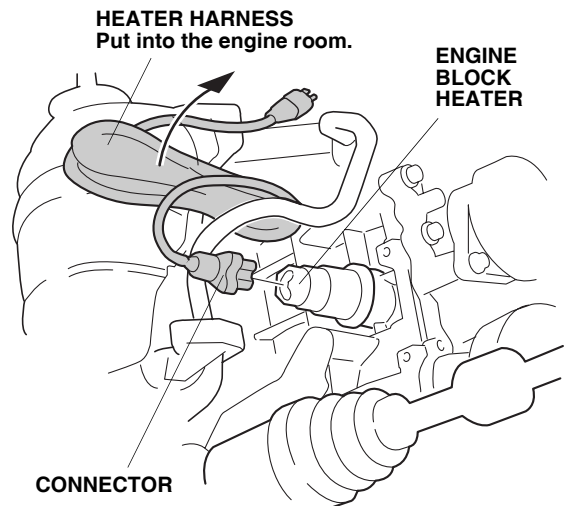

- Lower the vehicle.

11. Remove the grille cover (eight clips).

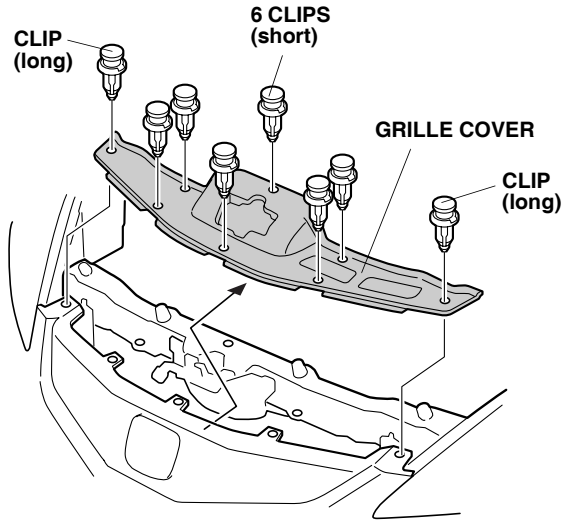

12. Using one washer-bolt, install the bracket as shown.

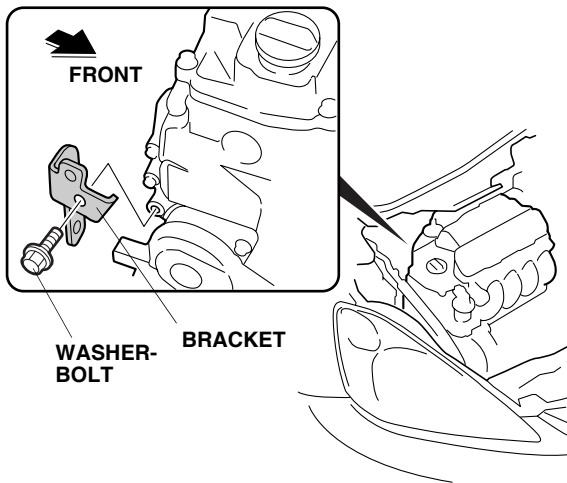

13. Route the heater harness as shown, and secure the two wire ties with clip (points A and B) to the bracket.

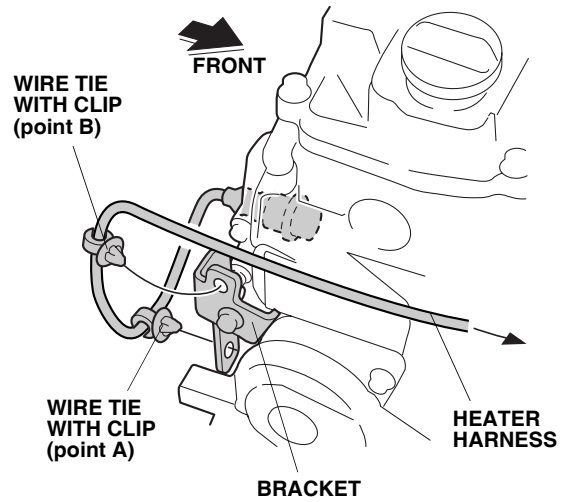

14. Route the heater harness as shown. Using two black wire ties, secure the heater harness to the vehicle harness.

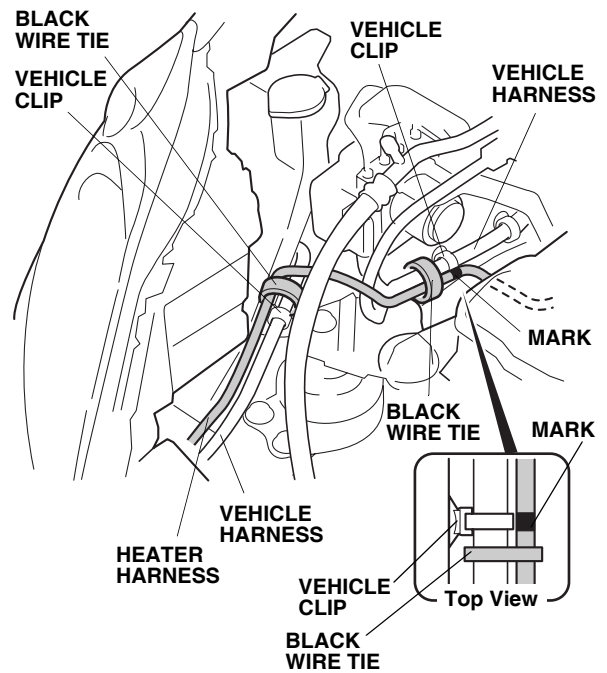

15. Route the heater harness as shown and secure the two wire ties with clips (points C and D) to the vehicle frame.

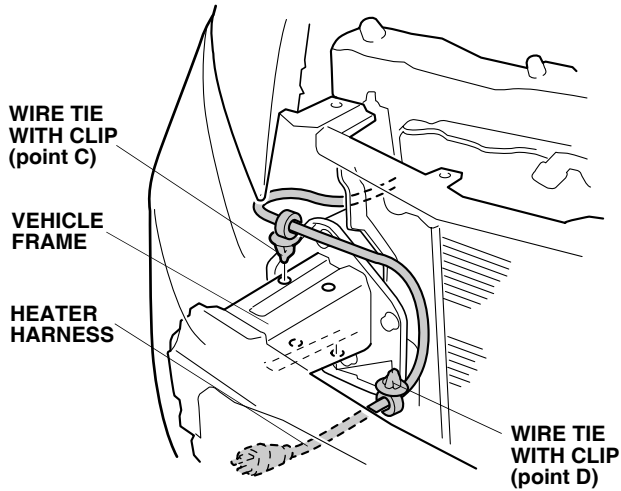

16. Bundle the excess of the heater harness. Using three black wire ties, secure the harness to the vehicle harness.

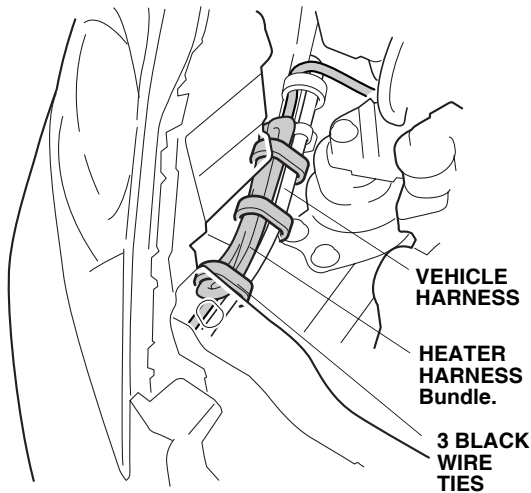

17. Route the heater harness:

- S-package: Route the heater harness as shown. Using one black wire tie, secure the heater harness to the front bumper grille. Attach the protective cap to the front bumper grille, and plug the connector of the heater harness into the protective cap.

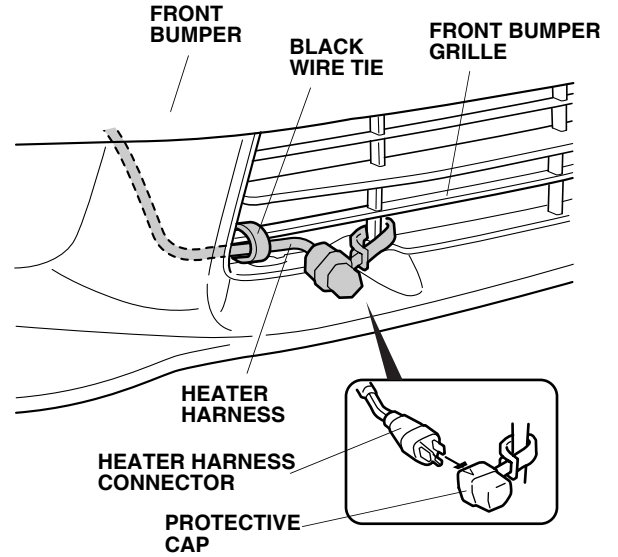

- Base model: Route the heater harness as shown. Using one black wire tie, secure the heater harness to the front bumper grille. Attach the protective cap to the front bumper grille, and plug the connector of the heater harness into the protective cap.

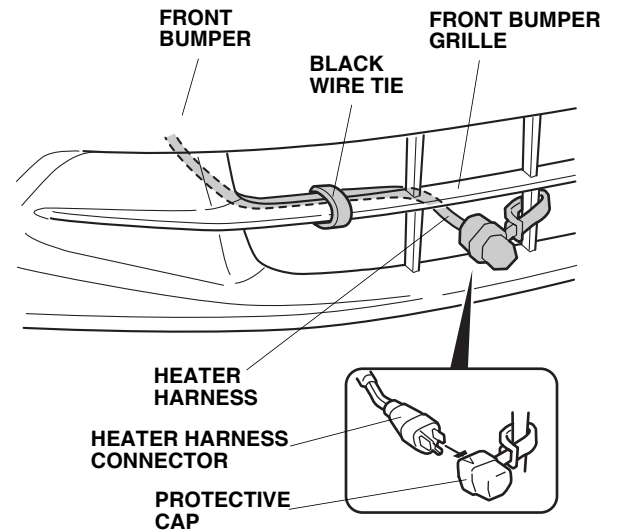

18. Reinstall all removed parts.
19. Reinstall the radiator drain plug.
20. Fill the system with coolant. Follow the instructions described in the service manual to fill and bleed the cooling system.
21. Check the coolant reservoir for correct level and check the cooling system for signs of leakage. Repair as necessary.
22. Check that the heater harness is routed properly and all connectors are plugged in.
23. Put the drain plug (removed in step 6) in the glove box.
24. Reconnect the negative cable to the battery.
25. Enter the audio unit anti-theft code, and reset the radio station presets.
26. Reset the clock.