



INSTALLATION INSTRUCTIONS

Accessory

SIDE UNDER SPOILER

Application

2009 FIT MUGEN

Publications No.

All 41060

Issue Date

APRIL 2009

NOTE: Side under spoilers cannot be installed on a vehicle equipped with splash guards.

PARTS LIST

Left side under spoiler

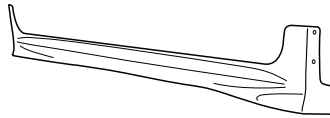

Right side under spoiler

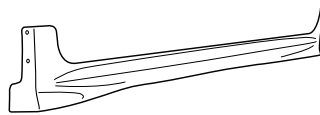

4 Special nuts



Template

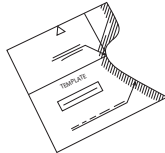

4 Self-tapping screws (5 mm)



18 Adhesive seals (2 not used)

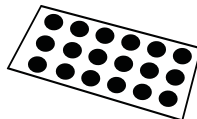

8 Bracket bolts



8 Nuts



4 Hex head screws (6 mm)



4 Grommets



2 Alcohol wipes



TOOLS AND SUPPLIES REQUIRED

Phillips screwdriver

Tape measure

Felt-tip pen

Shop towel

Isopropyl alcohol

Masking tape

Scissors

Touch-up paint

Rubber roller (P/N: EQSE54D)

INSTALLATION

Customer Information: The information in this installation instruction is intended for use only by skilled technicians who have the proper tools, equipment, and training to correctly and safely add equipment to your vehicle. These procedures should not be attempted by “do-it-yourselfers.”

NOTE:

- Allow the exhaust pipe to cool down before installing the right side under spoiler.
- Be careful not to damage the body finish when installing the side under spoilers.
- These installation instructions show the left side under spoiler being installed. The same procedure applies to installing the right side under spoiler.
- This side under spoiler kit should be installed only if the ambient air temperature is 60°F (15°C) or above.
- To allow the adhesive to cure, do not wash the vehicle for 24 hours.

- Turn the steering wheel all the way clockwise, and remove the left side sill panel.
 - Remove the two front clips from the front fenderwell area. Save the lower clip.
 - Under the side sill, remove the three clips.
 - Slide the side sill forward and remove it.

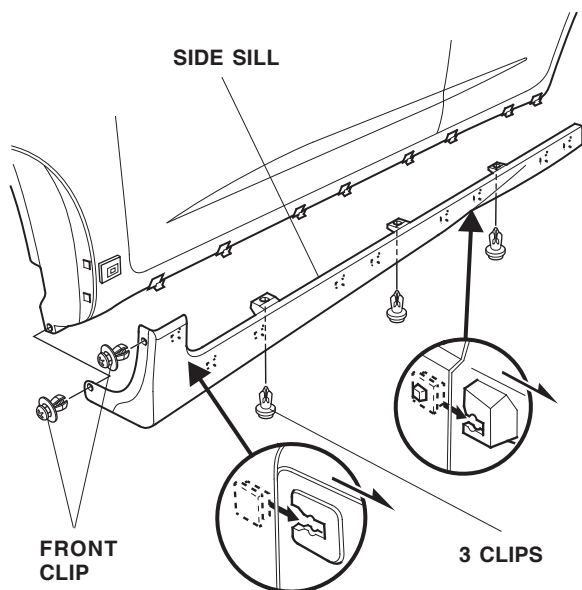

- Pull away the splash shield and install one grommet into each hole in the inner fender. If a plug or clip is already installed in the hole, remove and discard it first. Reinstall the lower clip.

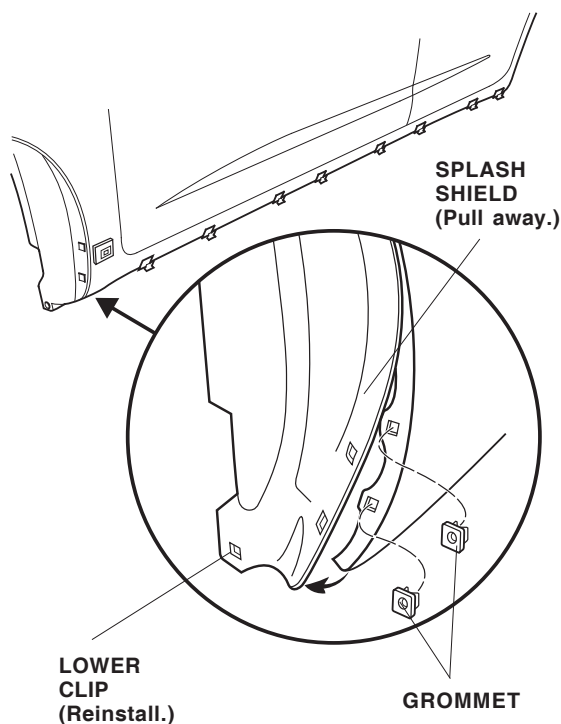

- Along the bottom of the body, remove and discard the 8 side clips. Turn each clip 90° to remove. Remove and discard the side clip from the front fender. Be careful not to scratch the paint.

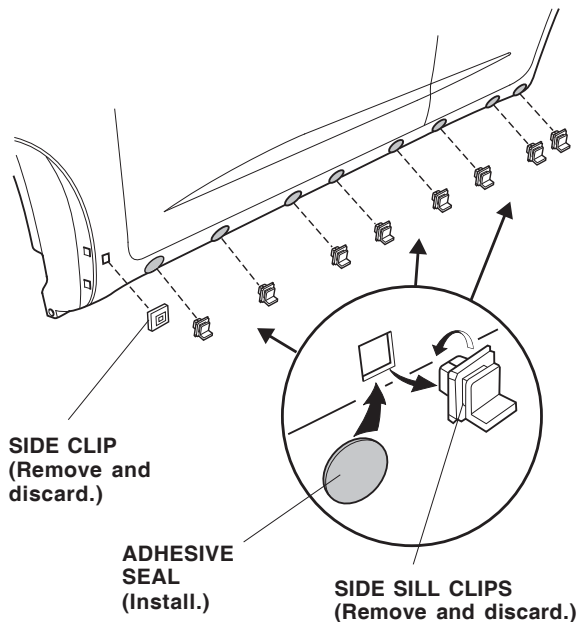

- Using isopropyl alcohol on a shop towel, clean the area around each clip hole. Allow the alcohol to dry, then attach one adhesive seal over each clip hole.
- At the front of the rear fenderwheel attach the two special nuts to the fender at the measurements shown. If necessary, remove any excess undercoating from the fenderwell. Apply touch up paint to the body if any undercoating was removed.

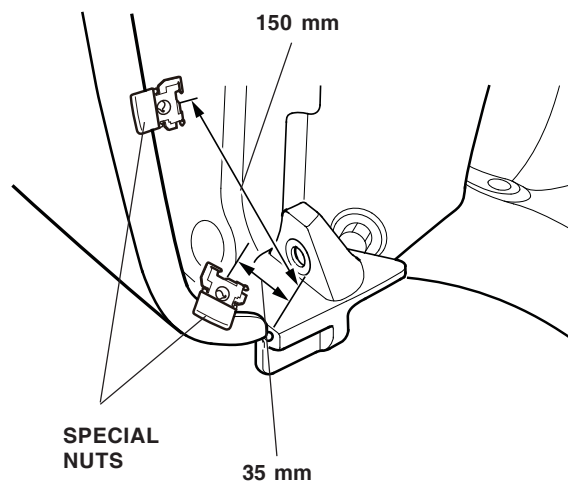

- Using scissors, cut out the template. With the doors open, measure and mark the door sill in three places at the measurements shown. Position the template at each of the three measurements, and mark the height of the side under spoiler.

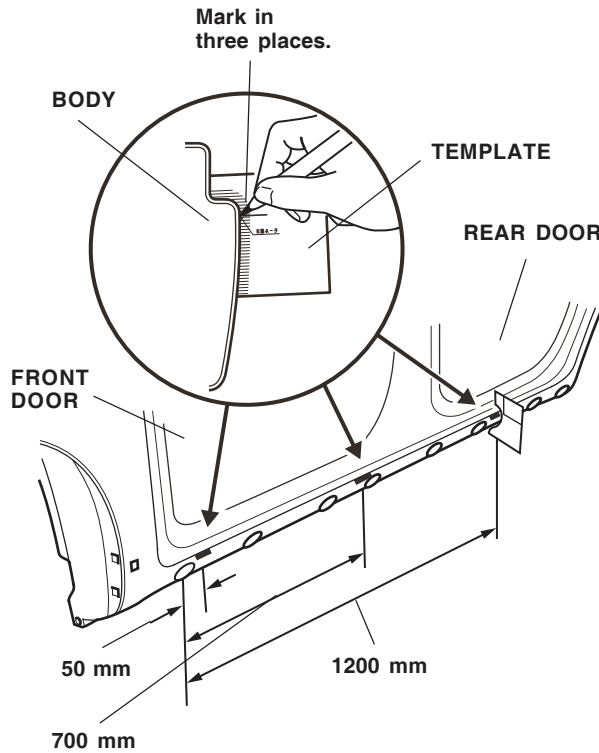

- Using isopropyl alcohol on a shop towel, clean the area where the side under spoiler will attach.

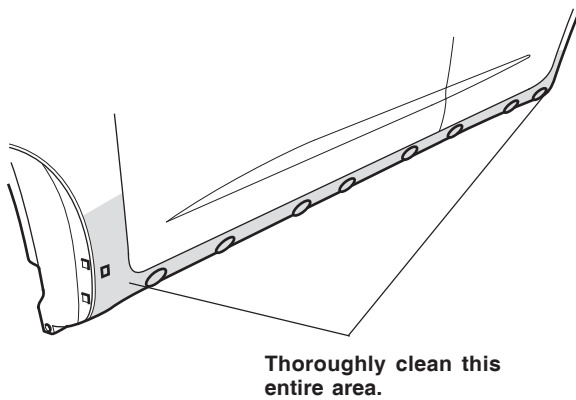

- Attach a strip of masking tape to the end of each adhesive backing, and peel back 1½ to 2 inches of adhesive backing. Fold the ends back, and tape them to the front of the side under spoiler.

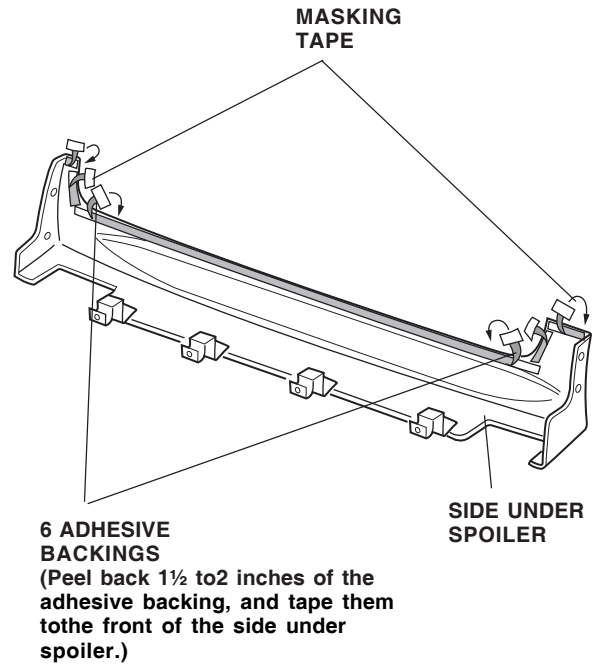

- Thread one nut onto each of the four bracket bolts, then loosely thread one bolt assembly into each bracket on the side under spoiler.

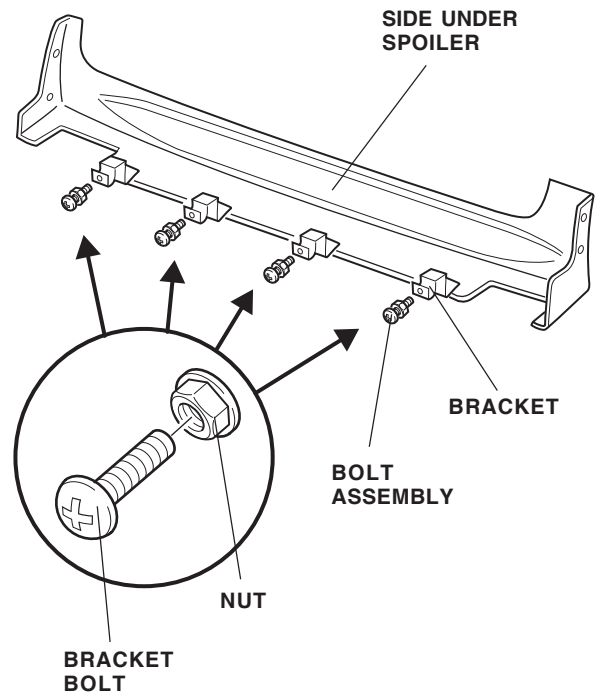

- With the help of an assistant, position the side under spoiler on the body and loosely thread in the bracket bolts to hold the spoiler in place.

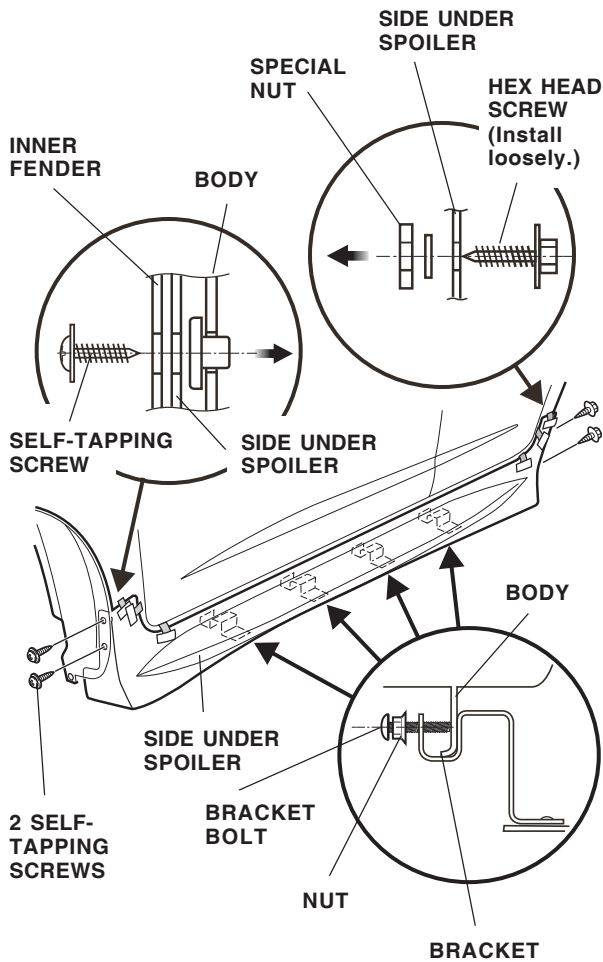

- With the front of the side under spoiler between the splash shield and the body, loosely install the two 5 mm self-tapping screws.
- Loosely install the two rear hex head screws.

- While holding the side under spoiler upward and against the body, tighten the front 5 mm screws.

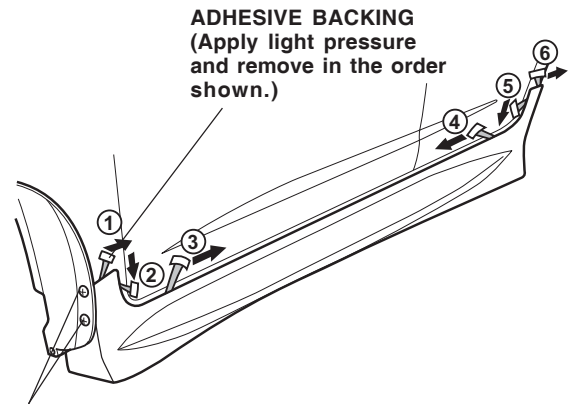

- Apply light pressure against the side under spoiler and slowly remove the adhesive backing in the order shown.
- Tighten the rear hex head screws installed in step 12.

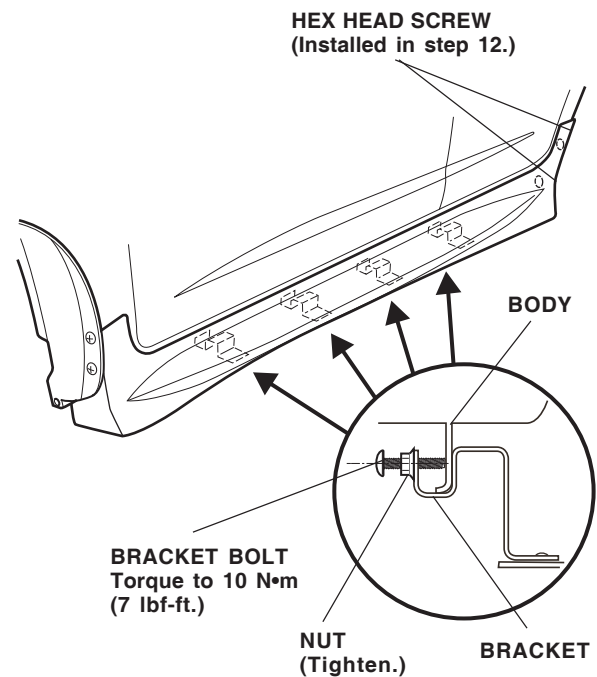

- Torque each bracket bolt to 10 N·m (7 lbf-ft.), then tighten the nuts.
- Using a rubber roller, apply firm pressure while rolling to set the adhesive.
- Turn the steering wheel all the way counterclockwise and repeat steps 1 thru 17 to install the right side under spoiler.