



# INSTALLATION INSTRUCTIONS

Accessory	Application	Publications No.
<b>FRONT UNDER SPOILER</b>	<b>2009 FIT MUGEN</b>	<b>All 41058</b>
		Issue Date
		<b>APRIL 2009</b>

## PARTS LIST

Front under spoiler

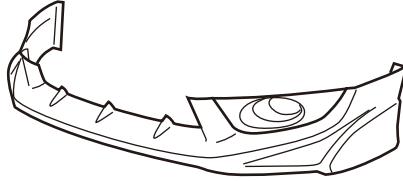

2 Self-tapping bolts



2 Grommets



4 Self-tapping screws



2 Clips



4 Spring nuts



Template

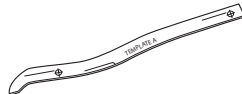

Alcohol wipes



8 Spacers



## TOOLS REQUIRED

Phillips screwdriver

Flat-tip screwdriver

Drill

3 mm, 6 mm and 10 mm Drill bits

Clip remover

Pushpin

Masking tape

Isopropyl alcohol

Shop towel

Eye protection

Rubber roller

## INSTALLATION

**Customer Information:** The information in this installation instruction is intended for use only by skilled technicians who have the proper tools, equipment, and training to correctly and safely add equipment to your vehicle. These procedures should not be attempted by “do-it-yourselfers.”

### NOTE:

- Using isopropyl alcohol on a shop towel, thoroughly clean the area where the front under spoiler will attach.
- Be careful not to damage the front bumper and body paint finish.
- This front under spoiler kit should be installed only if the ambient temperature is 60°F (15°C) or above.
- To allow the adhesive to cure, do not wash the vehicle for 24 hours.

1. Turn the steering wheel all the way clockwise, and attach the template to the left front fenderwell using strips of masking tape.

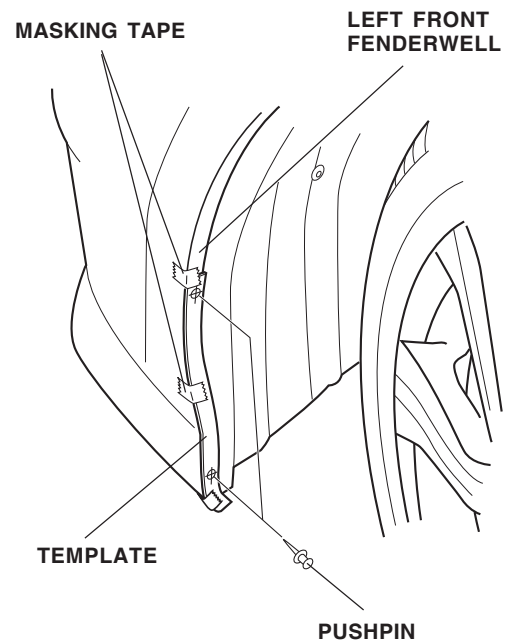

2. Using a pushpin, pierce the front fenderwell at the two marks indicated on the template.

3. While wearing eye protection, drill the two pierced marks on the front fenderwell to 6 mm.
  - First drill with a 3 mm drill bit and finish with a 6 mm drill bit.
  - Remove all burrs from each drilled hole.

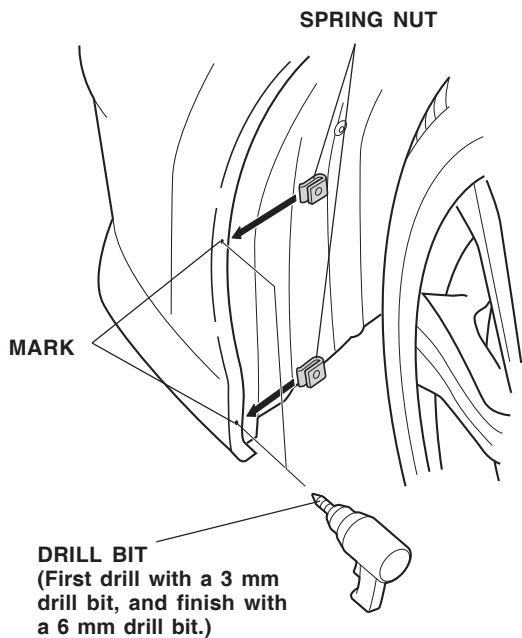

4. Install one spring nut over each drilled hole.
5. Turn the steering wheel all the way counterclockwise and repeat steps 2 thru 4 to mark and drill the right front fenderwell.
6. Under the front bumper, remove and discard the two front lower clips shown.

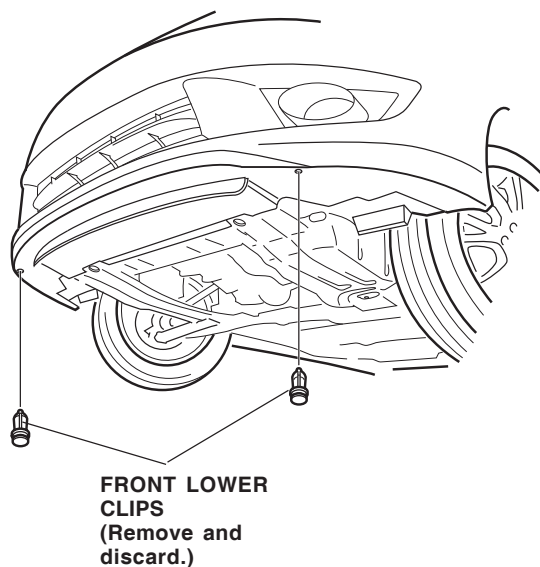

7. With the help of an assistant, temporarily install the front under spoiler to the front bumper using four self-tapping screws into the front fenderwell (two on each side) and two new clips under the spoiler.

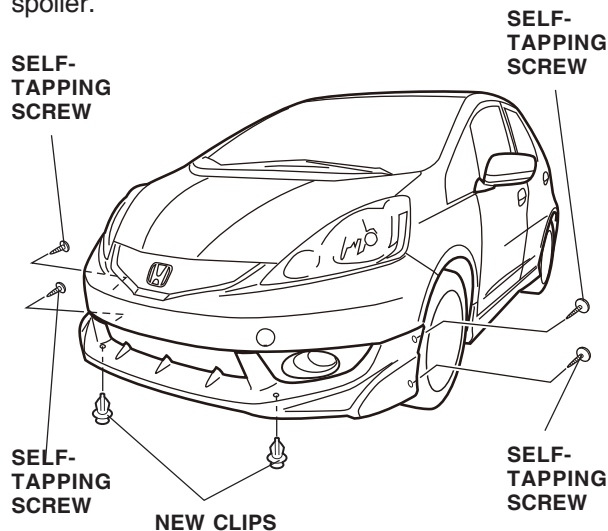

8. Under the spoiler, pierce the front bumper through the two holders on the spoiler.

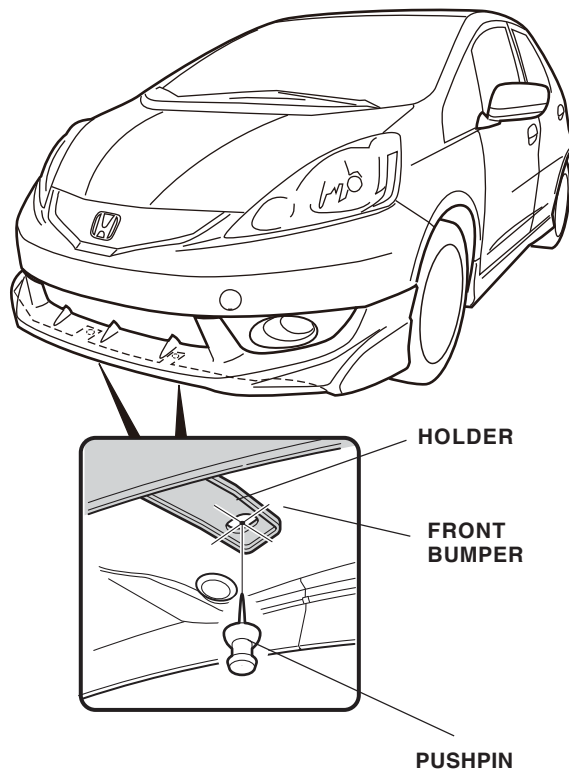

9. Remove the front under spoiler.

10. While wearing eye protection, drill the two pierced marks on the front bumper.
  - Wrap electrical tape around each drill bit 10 mm from the tip.
  - First drill with a 3 mm drill bit, then with a 6 mm drill bit, and finish with a 10 mm drill bit.
  - Remove all burrs from each drilled hole.

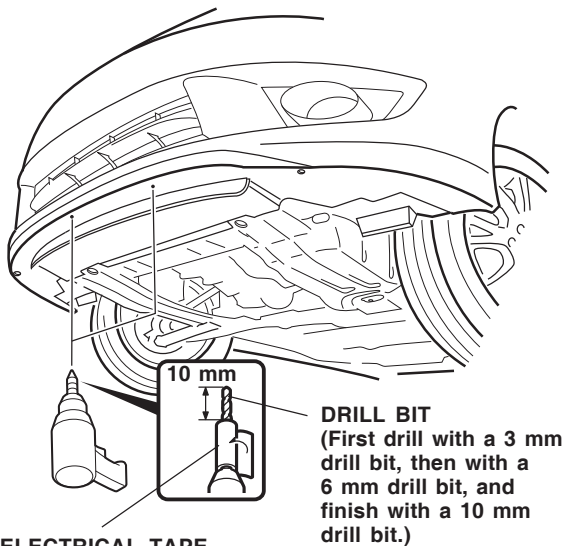

11. Insert one grommet into each drilled hole in the front bumper.

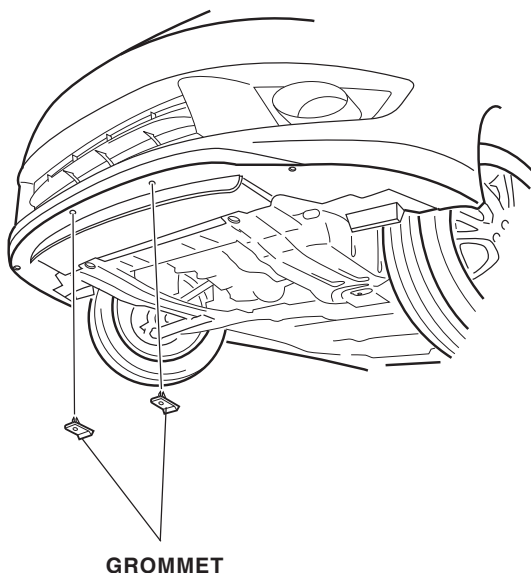

12. Attach a strip of masking tape to the end of each adhesive backing, and peel back 1½ to 2 inches of adhesive backing. Fold the ends back, and tape them to the front of the front under spoiler.

**ADHESIVE BACKING**  
 (Peel back 1½ to 2 inches of adhesive backing, and tape them to the front of the front under spoiler.)

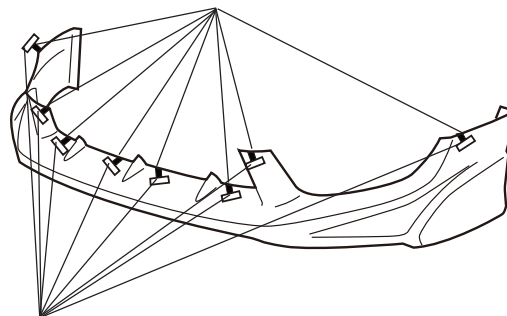

**MASKING TAPE**

13. Using isopropyl alcohol on a shop towel, clean the front bumper where the front under spoiler will attach.

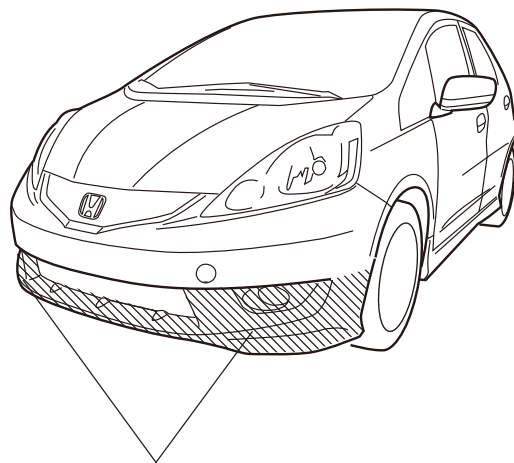

**Clean this entire area with the alcohol wipe.**

14. Position the front under spoiler on the front bumper. Loosely install four self-tapping screws (two at each fenderwell), and loosely install the two self-tapping bolts into the grommets installed in step 11. Install the two clips (from the kit) into the holes in the bottom of the front bumper.

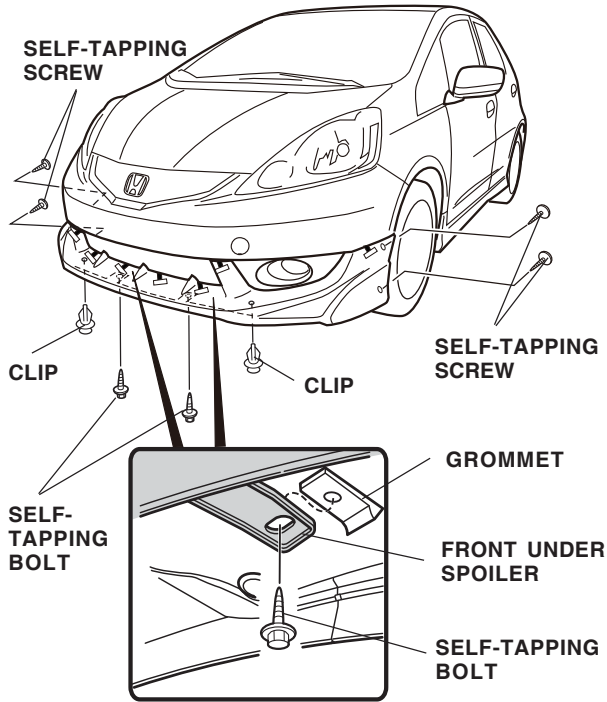

15. Make sure the front under spoiler is positioned properly on the front bumper with a 1 mm gap shown. Then, starting in the middle, slowly remove the lower adhesive backing while pushing inward. Remove the upper adhesive backing while gently lifting the under spoiler.

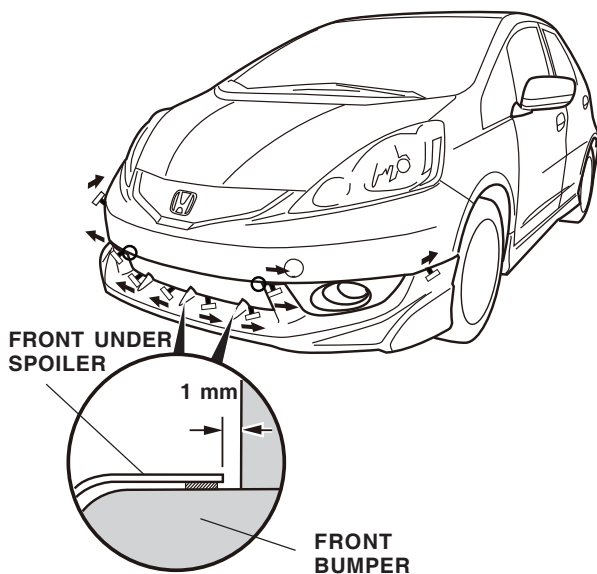

16. Using a rubber roller, apply firm pressure while rolling to set the adhesive.

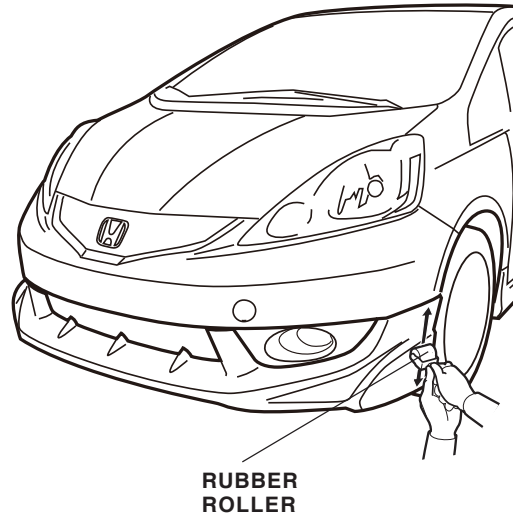

17. Tighten the self-tapping screws and bolts loosely installed in step 14. If there is a gap between the front bumper and the front under spoiler, use a 1 mm shim to close the gap. In some cases you may need to add two 1 mm shims to close the gap. Do not add more than two shims under each screw.

