



INSTALLATION INSTRUCTIONS

Accessory
ALUMINUM WHEEL
P/N 08W17-SNA-101A

Application
2009 CIVIC
2 AND 4-DOOR

Publications No.
All 40166

Issue Date
AUG 2008

PARTS LIST

Aluminum wheel
(The illustration may differ from the actual wheel.)

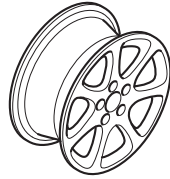

Center cap



Tire pressure caution label

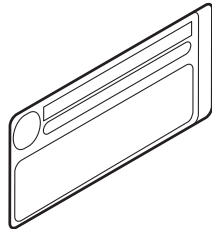

Tire pressure caution label C

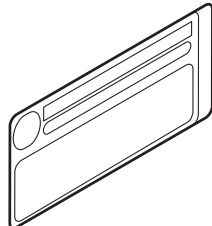

Tire pressure caution label D

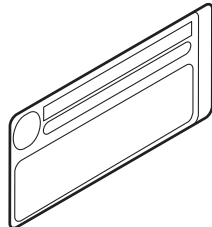

Supplemental Information

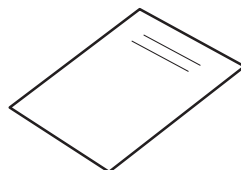

Parts for TPMS sensor assembly

Tire pressure sensor

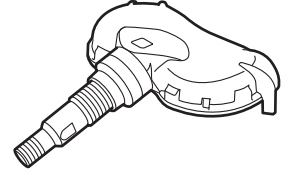

Washer



Valve cap
(The valve cap may be assembled the tire pressure sensor.)

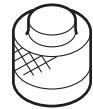

Valve nut



TOOLS AND SUPPLIES REQUIRED

Ratchet
11 mm Socket
Torque wrench
Isopropyl alcohol
Shop towel
HDS (Honda Diagnostic System)
Snap-on TPMS sensor initializer tool

SPECIFICATIONS

Models not equipped with standard 17" wheels:

Rim size	17 x 7 J (offset 45)	
Tire side	215/45ZR17 91W	
Bolt hole PCD	114.3 (5 holes)	
Tire pressure	Front	220kPa (2.2 kgf/cm ² , 32 psi)
	Rear	220kPa (2.2 kgf/cm ² , 32 psi)

Models equipped with standard 17" wheels:

Refer to the owner's manual.

INSTALLATION

Customer Information: The information in this installation instruction is intended for use only by skilled technicians who have the proper tools, equipment, and training to correctly and safely add equipment to your vehicle. These procedures should not be attempted by "do-it-yourselfers."

NOTE:

- This aluminum wheel is designed for use on the TPMS (Tire Pressure Monitoring System) vehicle.
- This aluminum wheel is equipped with the TPMS sensor. See the Service Manual for tire replacement procedure and TPMS sensor installation procedure (paragraph of Tire Pressure Sensor Replacement).
- The illustration of the aluminum wheels are shown for reference purposes only.
- Install the correct size tire.
- Use a tire changer to remove and install the tires. Using a tire lever to remove and install the tires can damage to the tire, the wheel, and the TPMS sensor.
- The wheel nut torque is 108 N·m (11 kgf·m, 80 lbf·ft)
- The standard wheel nuts may not be used with the aluminum wheels. Replace them with the correct wheel nuts which are sold separately as described.

for wheels with cap

for aluminum wheels



1. Clean the mating surface and the valve hole of the aluminum wheel.

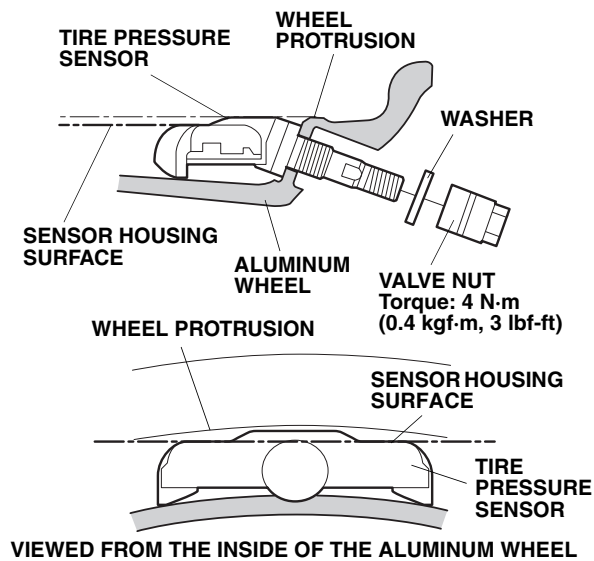

2. Install the tire pressure sensor and the washer to the aluminum wheel, and loosely install the valve nut. Make sure the pressure sensor is resting on the wheel.

NOTE: Install the tire pressure sensor so that the sensor housing surface should not exceed the wheel protrusion to prevent the sensor housing caught to the bead of the tire when assembled the tire.

3. Tighten the valve nut to the specified torque while holding the tire pressure sensor toward the wheel. Tightening torque: 4 N·m (0.4 kgf·m, 3 lbf·ft)

NOTE:

- Do not reuse the grommet that had been tightened, even one time, to the specified torque, as they are deformed inside.
 - Do not use pneumatic or electric tools on the valve nut.
 - Tightening the nut to the specified torque or above can damage the grommet.
4. Install the tires according to the instructions in the service manual.
 5. Install the wheels on the vehicle and torque to 108 N·m (11 kgf·m, 80 lbf·ft).

Models equipped with standard 17" wheels.

Tire pressure caution label and Supplemental Information are not used.

Perform steps 6 and 7 for models not equipped with standard 17" wheels.

6. Open the driver's door. Using isopropyl alcohol, clean the area where the accessory tire pressure caution label will attach. Remove the backing from the label and attach it over the existing tire information label. Attach the tire pressure caution label or label C or label D according to the following information:

Label: For EX-L Model with a T125/70D15 95M
 Label C: For EX-L Model with a T135/80R16 101M
 Label D: For EX-L Model with a T135/80D16 101M

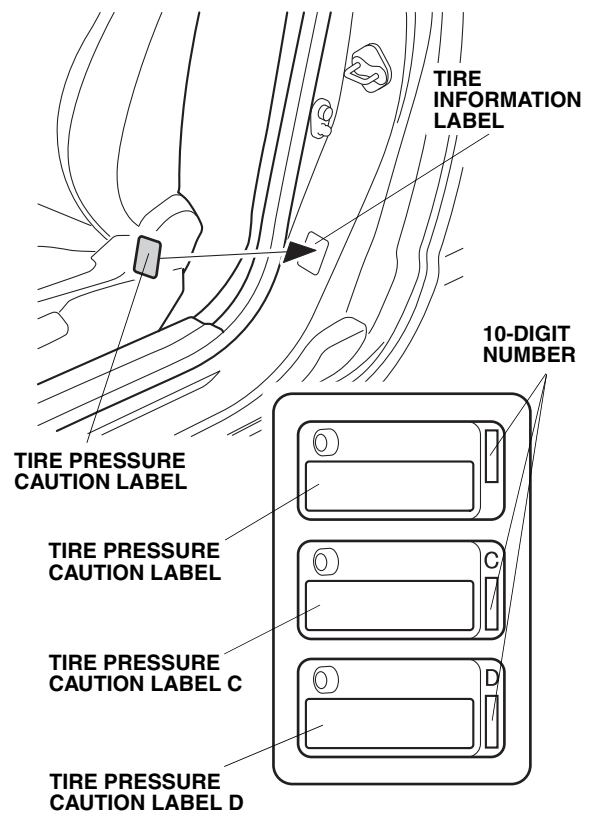

7. Attach the "Supplemental Information" page included in this kit to the owner's manual. For the method of attaching the page, refer to "To the dealer:" attached to the "Supplemental Information" page.

MEMORIZING THE TIRE PRESSURE SENSOR ID

- Using the HDS and Snap-on TPMS sensor initializer tool, memorize the ID of tire pressure sensor ID according to the instructions in the service manual (Memorizing the Tire Pressure Sensor ID).

