



INSTALLATION INSTRUCTIONS

Accessory

**BACKUP SENSOR
P/N 08V67-SJC-101**

Application

2008 RIDGELINE

Publications No.

All 36577

Issue Date

JUN 2007

PARTS LIST

Backup sensor harness

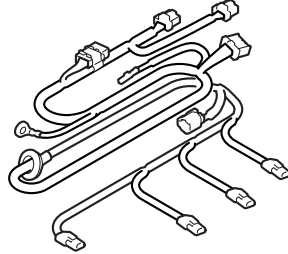

Control unit

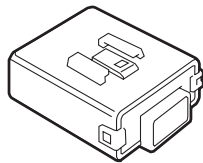

Buzzer

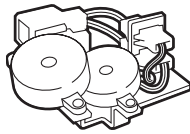

Fuse label

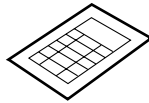

4 EPT sealers

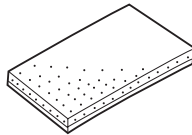

40 Wire ties

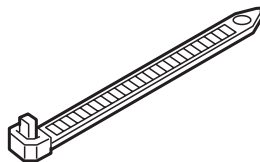

9 Small wire ties

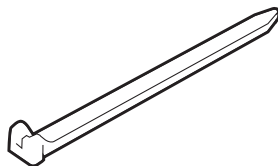

2 White wire ties with clips

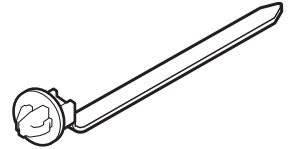

Flange bolt

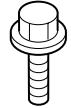

Buzzer bracket

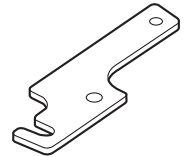

Control unit bracket

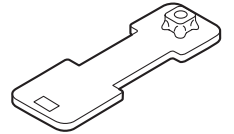

Switch

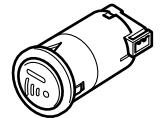

Ground bolt

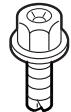

2 Corner sensors

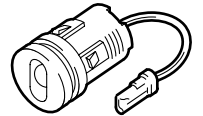

2 Center sensors

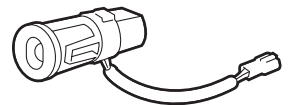

2 Retainer clips



3 Cushion tapes

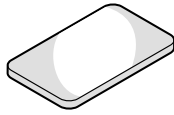

Owner's manual

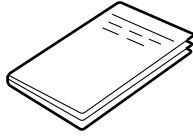

Tailgate switch

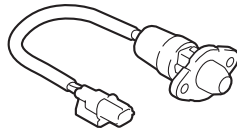

Tailgate switch bracket

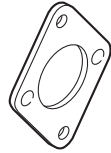

Template

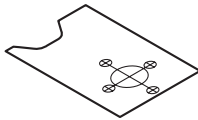

4 Screws, 4 x 14 mm



2 Blind nuts

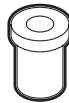

Corrugated tube

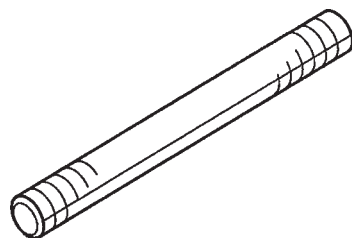

Flange nut



Washer-bolt

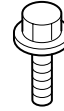

TOOLS AND SUPPLIES REQUIRED

#2 Phillips screwdriver

Small flat-tip screwdriver

10 mm Combination wrench

10 mm and 14 mm Socket

Pushpin

Ratchet

3 mm and 8 mm, Drill bits

Eye protection (face shield, safety goggles, etc.)

File

Diagonal cutters

Tape measure

Isopropyl alcohol

Shop towel

20 mm and 26 mm Hole saws

Drill

Utility knife

Scissors

T-30, T-40, and T-50 Torx driver

Electrical tape

Center punch

Illustration of the Backup Sensor Installed on the Vehicle

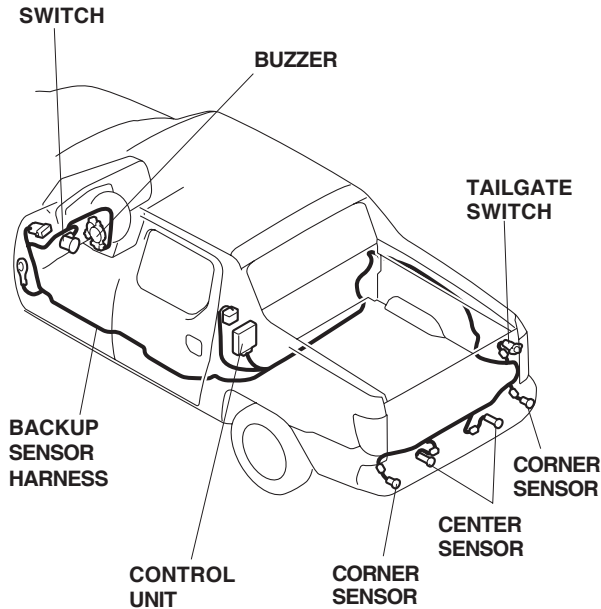

INSTALLATION

Customer Information: The information in this installation instruction is intended for use only by skilled technicians who have the proper tools, equipment, and training to correctly and safely add equipment to your vehicle. These procedures should not be attempted by “do-it-yourselfers.”

1. Make sure you have the anti-theft code for the radio, then write down the radio station presets .
2. Disconnect the negative cable from the battery.

3. Remove the left dashboard side cover (seven clips).

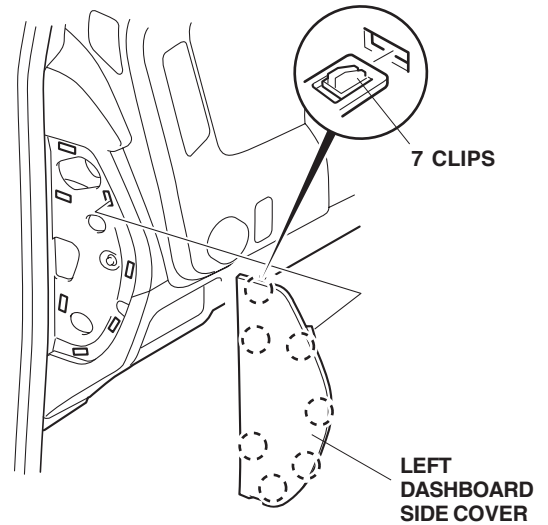

4. Remove the driver’s dashboard lower cover:
 - Remove the one self-tapping screw.
 - Release the nine clips, and pull out the driver's dashboard lower cover.
 - Unplug the vehicle connectors, and remove the vehicle tube. Remove the lower cover.

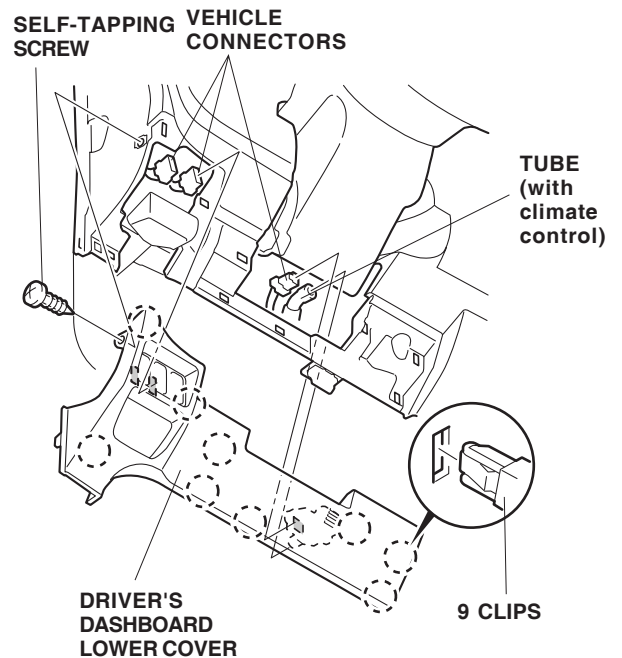

5. Remove the driver's console side trim (three retaining clips and one tab).

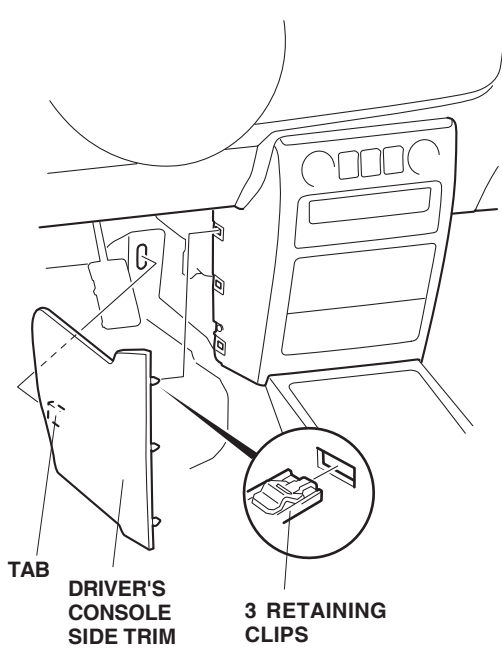

6. Remove the passenger's console side trim (two retaining clips and one tab).

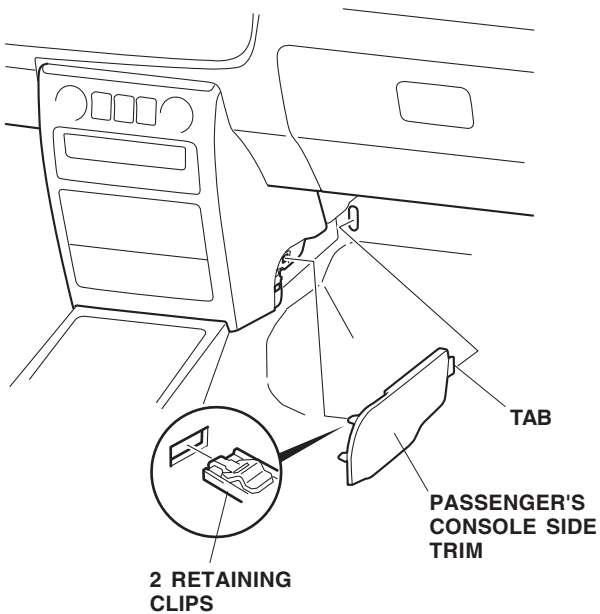

7. Remove the center console lower cover
 - Remove the center pocket.
 - Remove the three self-tapping screws.
 - Release the five retaining clips and six retaining tabs, and pull out the dashboard console lower cover.
 - Disconnect the vehicle connectors, and remove the center console lower cover.

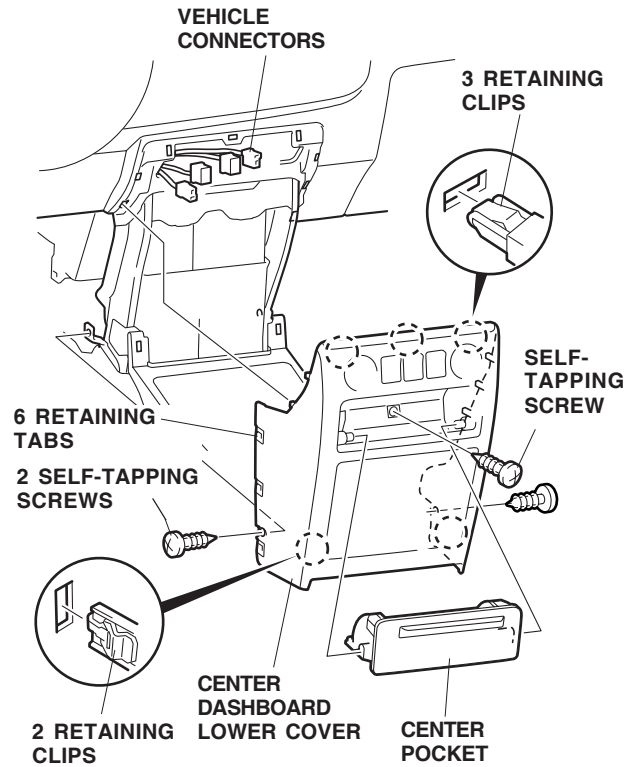

8. Pull out to the fuel fill door release handle. Remove the left front door sill trim (three clips and three retaining tabs).

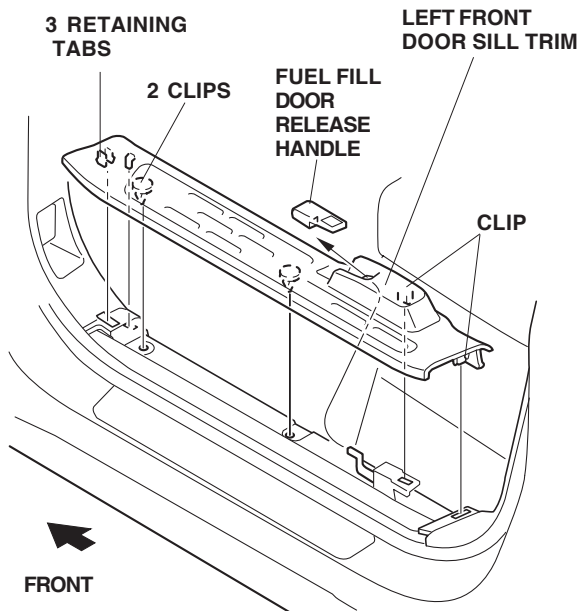

9. Pull away the weatherstrip from around the driver's kick panel. Remove the driver's kick panel (one screw clip and one clip).

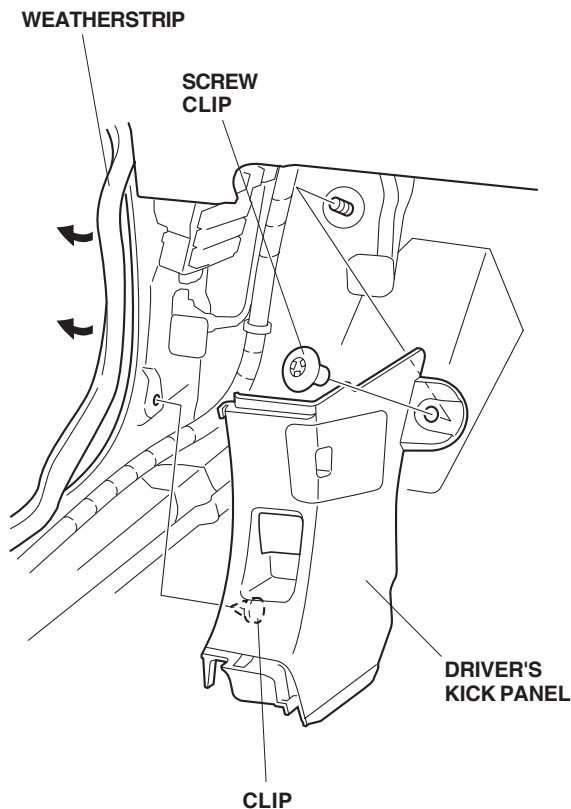

10. Remove the left and right rear door sill trim (three clips and five retaining tabs).

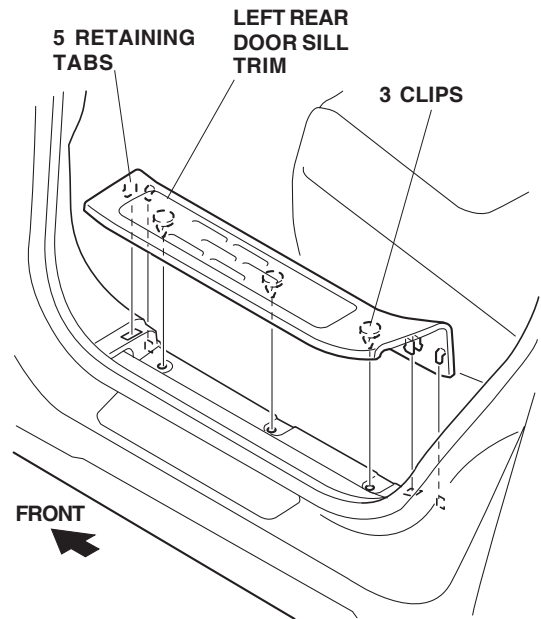

11. Pull away the weatherstrip from the B-pillar lower trim panel. Remove the left seat belt lower anchor bolt cover, and remove the lower anchor bolt. Remove the left B-pillar lower trim panel by pulling out toward you as shown.

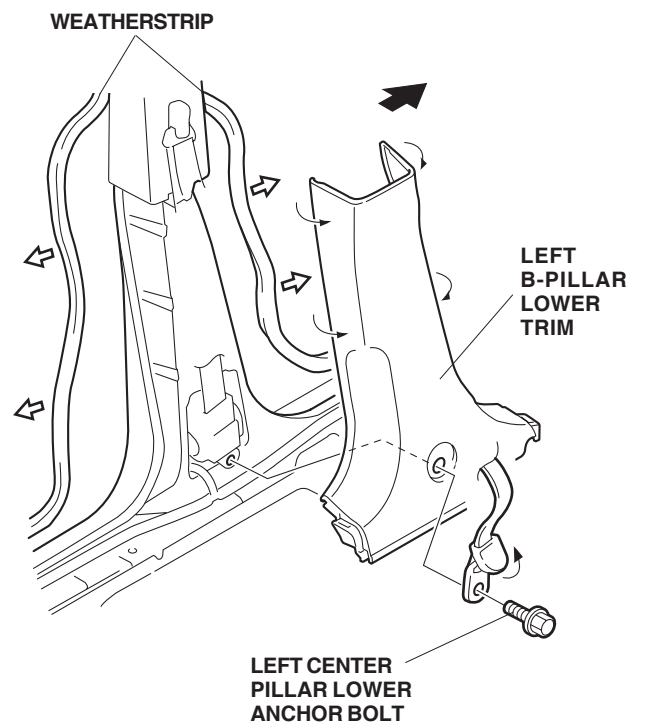

12. Lift up the rear seats, and remove the rear under-seat trim panel.

- Remove the left rear under-seat trim panel (seven clips).
- Remove the right rear under-seat trim panel (four clips).

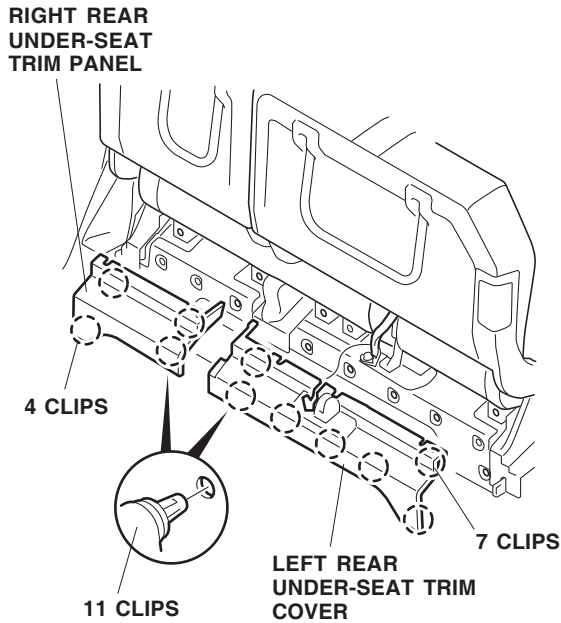

13. Remove the rear seat mount covers:

- Remove the left and right rear seat mount covers (two clips for each cover).
- Remove the upper middle rear seat mount cover (hold the seat belt buckles down, and pull up to release the two clips and nine retaining tabs).
- Remove the lower middle rear seat mount cover (two clips).

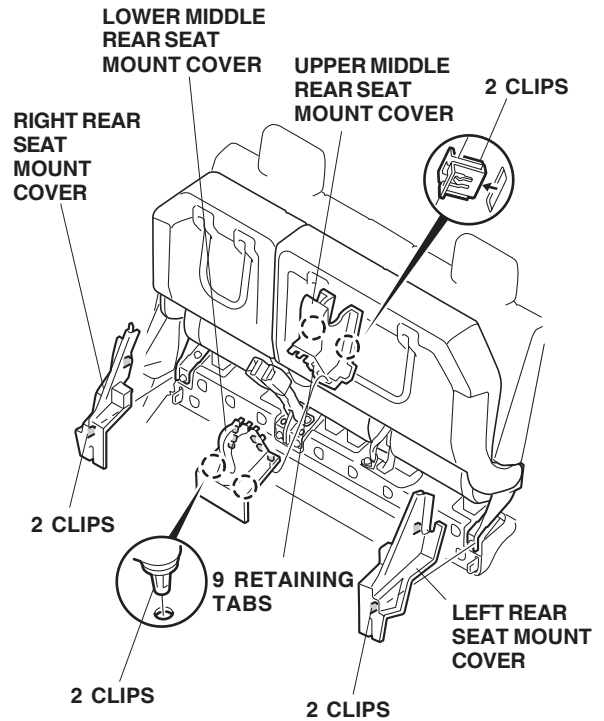

14. Remove the caps from the rear trim panel cover (four retaining tabs for each cover).

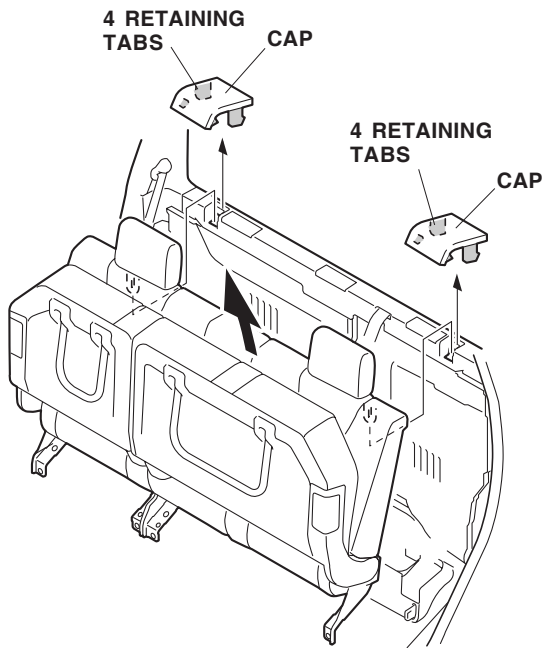

15. Remove the rear seat belt anchor bolts.

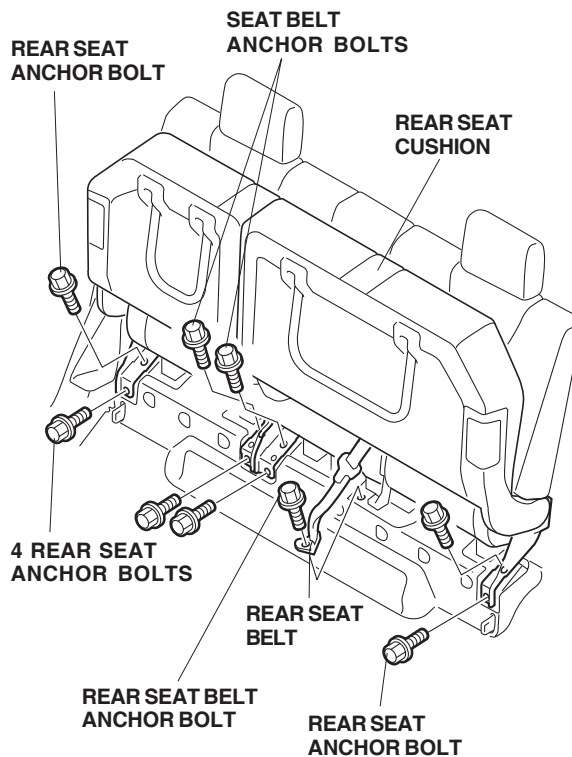

16. Remove the eight rear seat anchor bolts, and remove the rear seat cushion.

17. Remove the rear trim panel (eight clips and two retaining tabs).

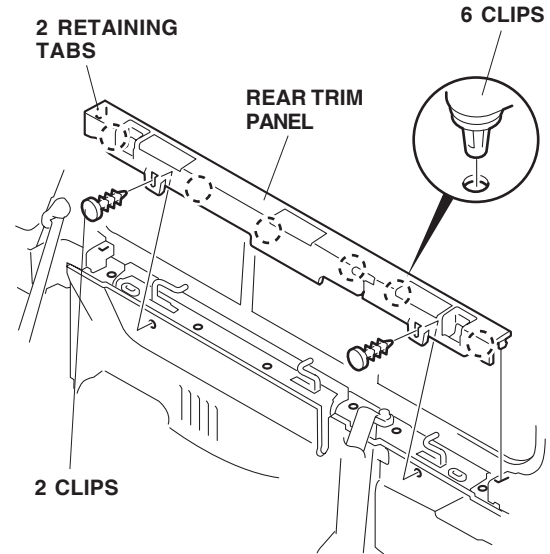

18. Remove the seat belt upper anchor bolt cover (three retaining tabs), and remove the right rear seat belt upper anchor bolt.

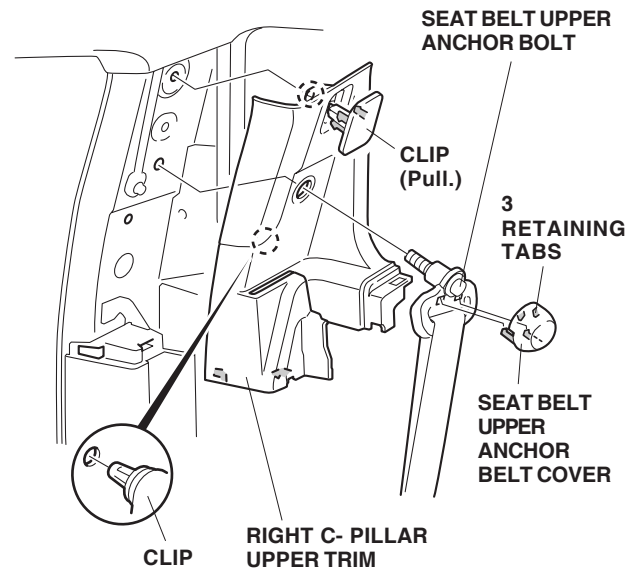

19. Remove the right C-pillar upper trim.

- With side airbag; pull the clip, and remove the right C-pillar trim by releasing the one clip.
- Without side airbag; remove the right C-pillar trim by releasing the two clips.

20. Pull up the seat belt lower anchor bolt cover, and remove the seat belt lower anchor bolt.

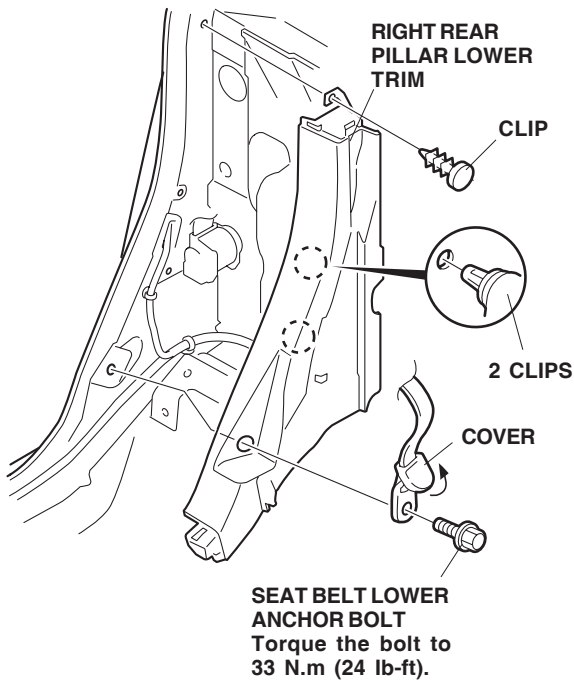

21. Remove the upper clip, then remove the right rear pillar lower trim by releasing the two clips.
22. Repeat steps 18 thru 21 to remove the left C- pillar upper and lower trim.

If the vehicle you are working on is equipped the subwoofer, continue with step 23; otherwise, go to step 24.

23. Unplug the vehicle connector. Remove the four bolts, and remove the subwoofer by pulling upward to release the two hooks.

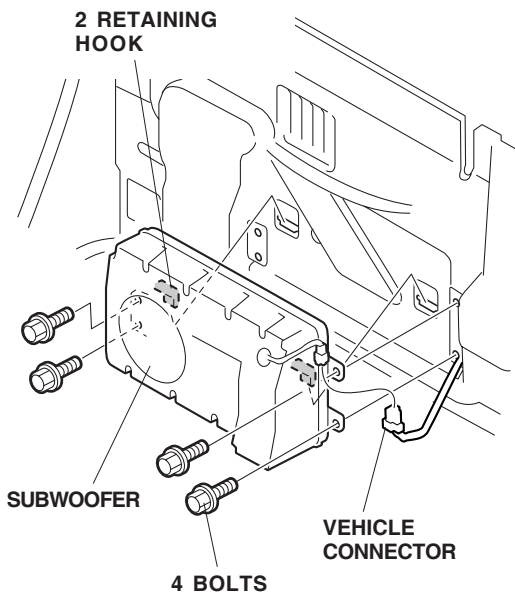

24. Remove the rear trim panel (three clips).

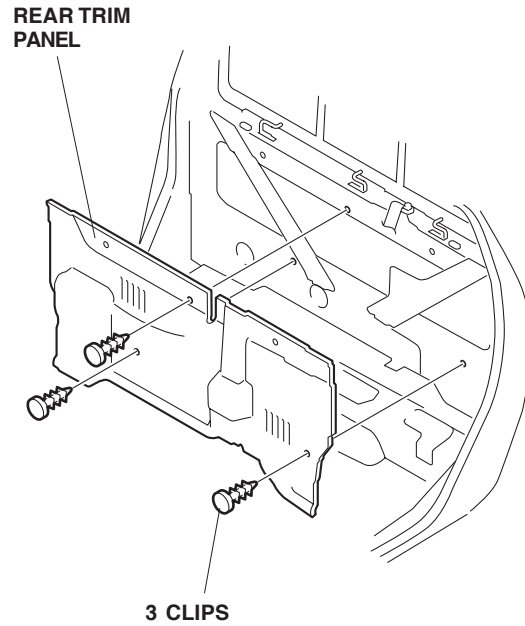

25. Remove the rear roof trim.

- Remove the rear roof trim bolt covers (three retaining tabs for each). Remove the two roof trim nuts.

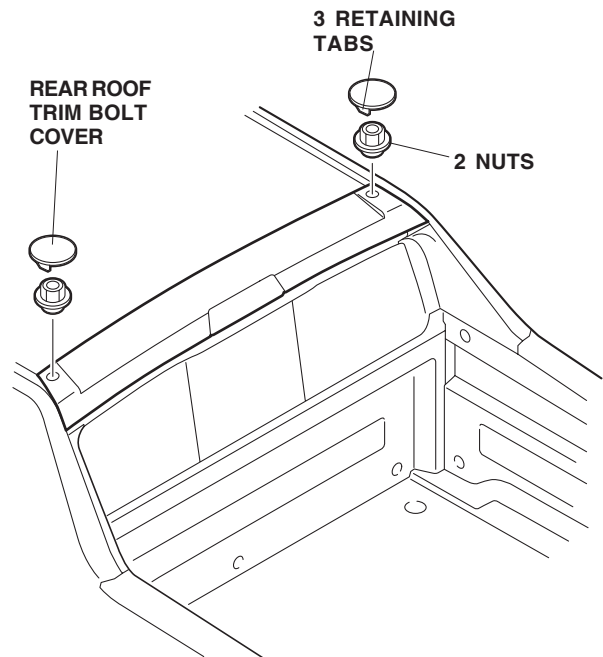

- Using the KTC trim tool, carefully pry up the front of the trim to release the three front clips. Start with the left clip, and work your way to the right clip.
- Gently lift the front of the trim to release the four remaining clip.

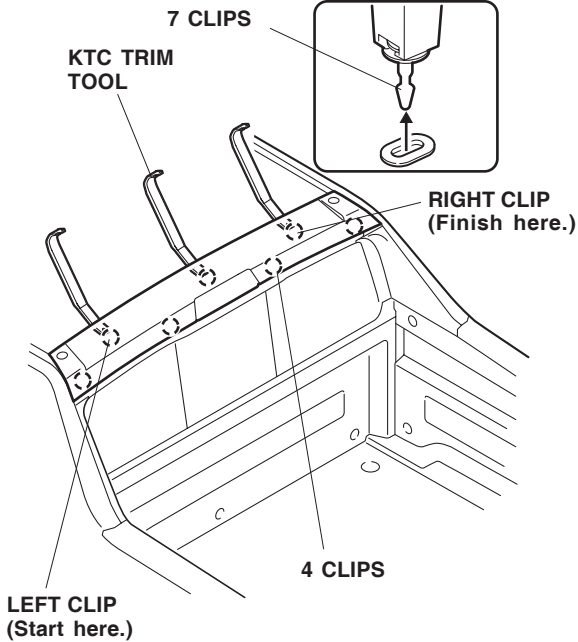

- Gently pull up the rear roof trim by releasing the two hooks. Remove the antenna grommet and high-mount brake light grommet from the roof panel, disconnect the vehicle connectors, and remove the roof trim.

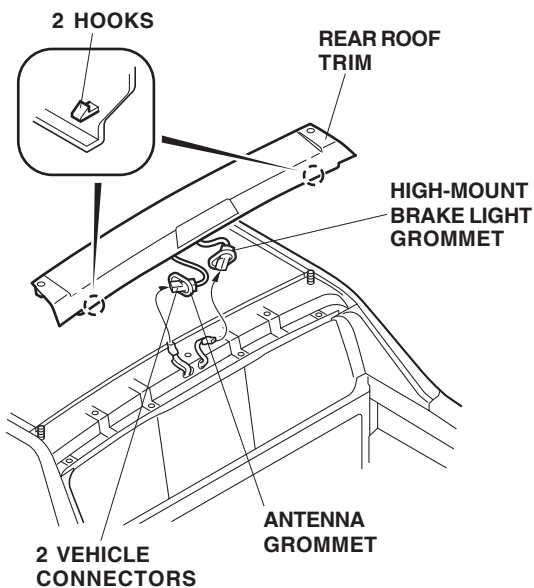

26. Remove and discard the grommets from the roof panel. Install the six ellipse grommets and one circle grommet into the roof panel.

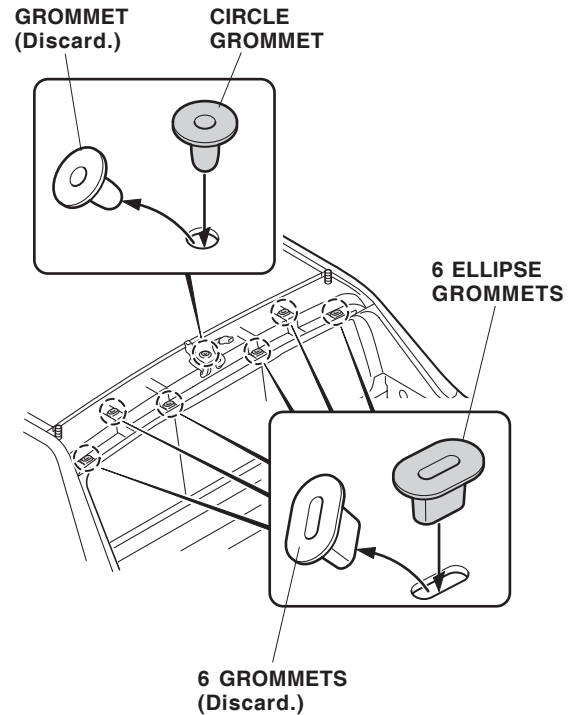

27. On the inside of the rear roof trim, remove and discard the clips, and install the seven new clips to the rear roof trim.

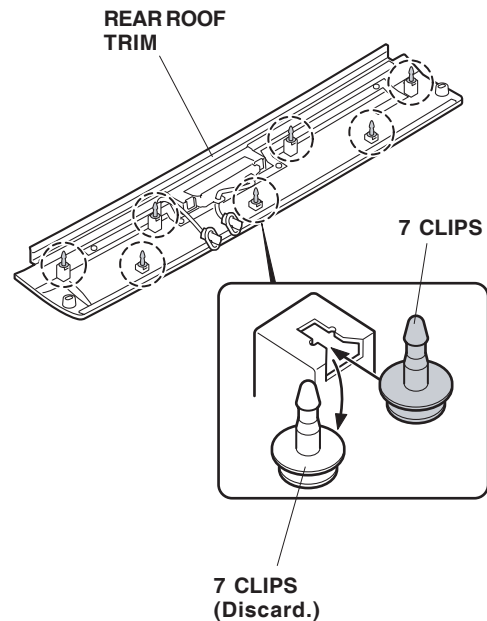

28. Remove the right bed rail trim:

- Remove the screw cover (four retaining tabs).
- Remove the one self-tapping screw from the rear of the bed rail trim.
- Pull the bed rail trim back to release the six clips, and remove the bed rail trim.

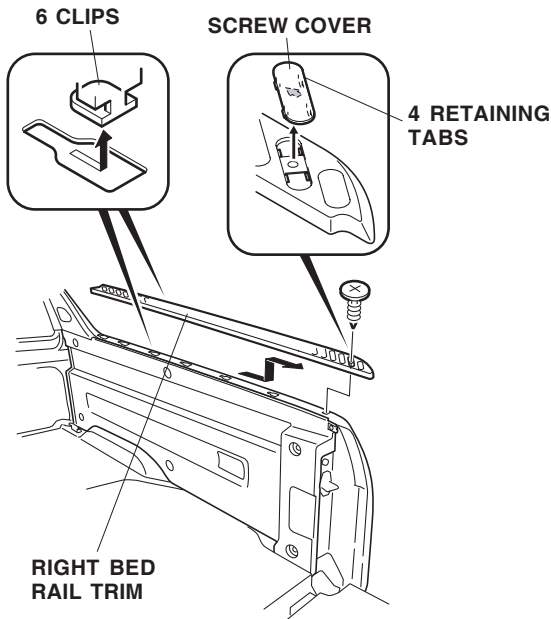

29. Remove the light first, then remove the right C-pillar outer trim. Slide rearward, and disconnect the vehicle connector. Remove the clips from the body, and reinstall the clips to the C-pillar outer trim.

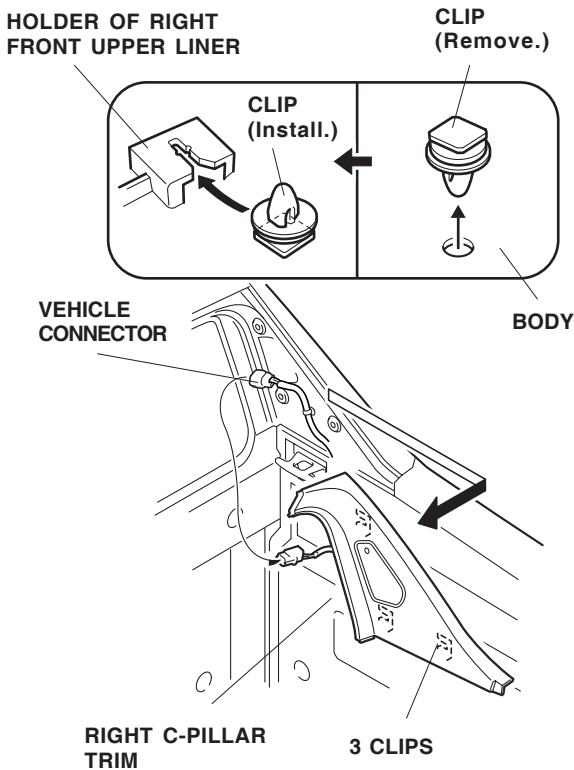

30. Remove the left front upper tie-down hook (two torx bolts). Remove the right front upper tie-down hook.

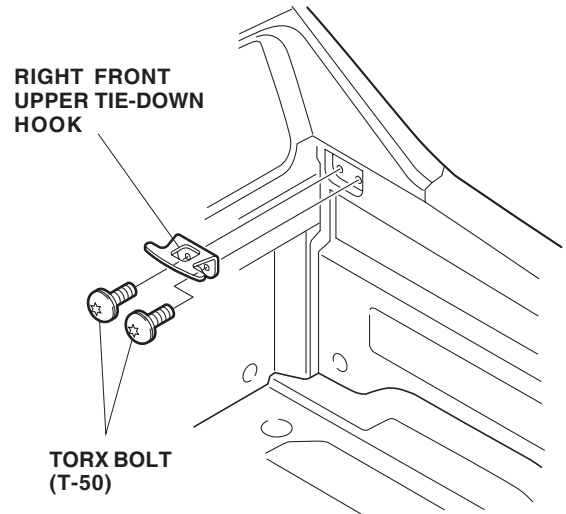

31. Remove the front bed panel (six torx bolts).

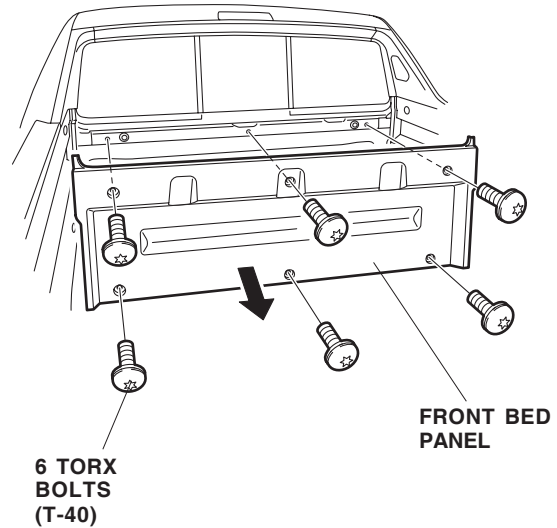

32. Remove the right lower bed light (one self-tapping screw), pull the light out toward you, and unplug the vehicle connector.

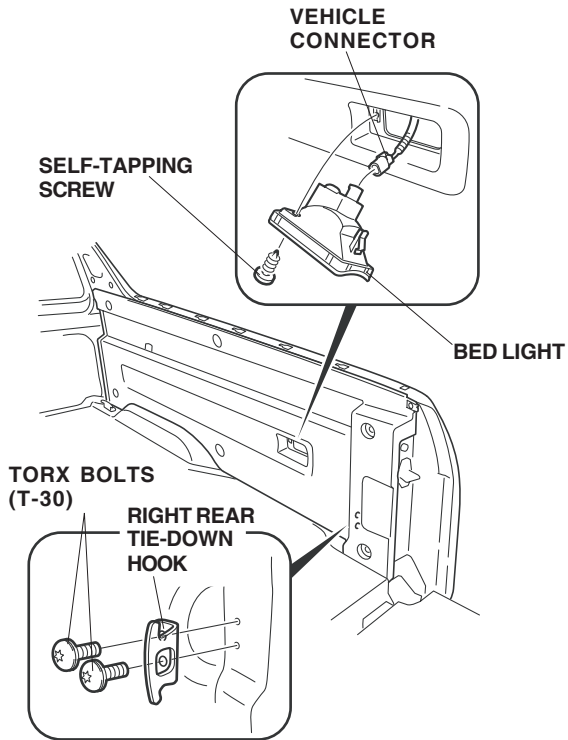

33. Remove the right rear tie-down hook (two torx bolts).
34. Remove the right side bed panel (six torx bolts).

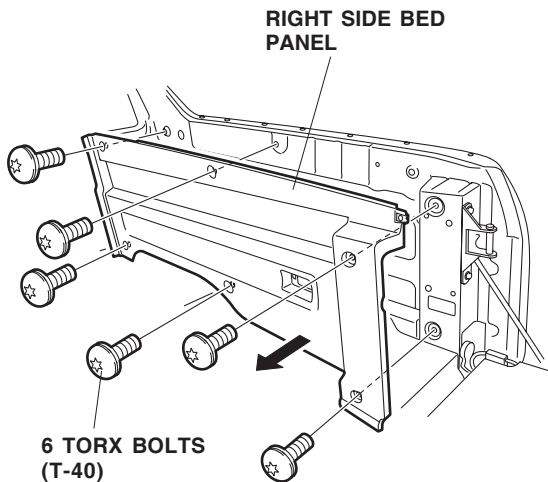

35. Remove the left and right rear taillights (two bolts), and pull the taillight rearward to release two clips. Release the vehicle connector. Unplug the vehicle connector, and remove the taillight.

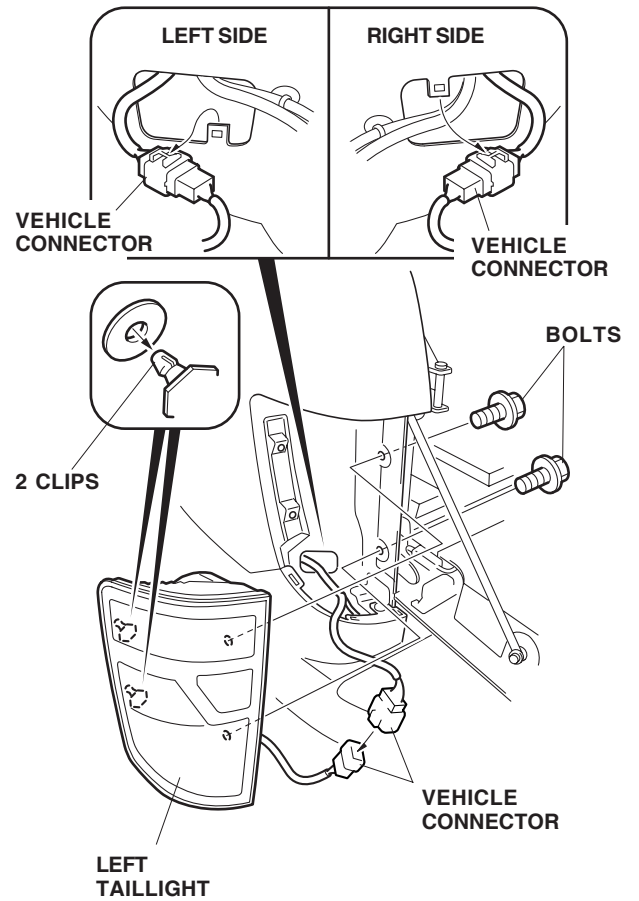

36. Remove the rear bumper:

- Remove the license plate (two bolts).
- Remove two bolts, ten self-tapping screws and six clips from the rear bumper.
- With the help of an assistant, pull the rear bumper toward you. Unplug the two vehicle connectors, and remove the rear bumper.
- Set the rear bumper on the blanket.

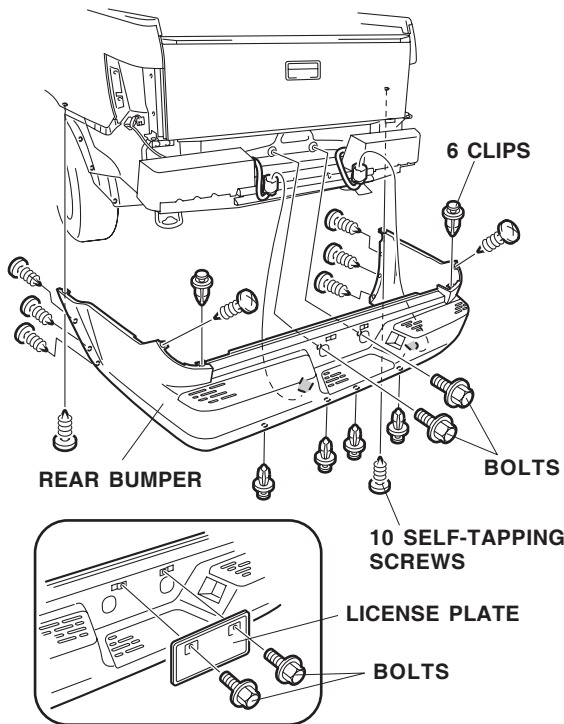

Cutting the Rear Bumper

37. On the inside of the rear bumper, locate the backup sensor preset marks on the left side. Mark the rear bumper at the left and center preset marks. There are two sets of preset marks on the bumper, use the lower marks.

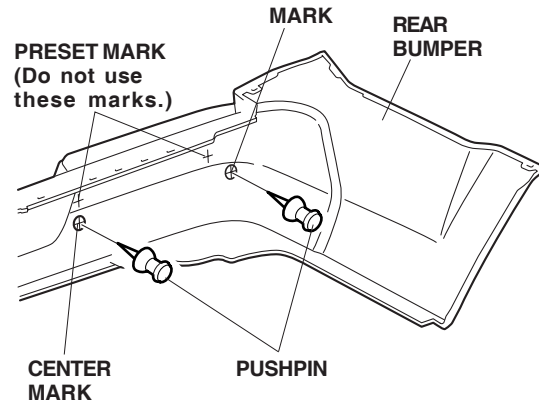

38. While wearing eye protection, drill one 19 mm ($\frac{3}{4}$ in.) hole and one 25 mm (1 in.) hole through the marks on the rear bumper. First drill with a 3 mm bit, then finish with a 19 mm ($\frac{3}{4}$ in.) hole saw and 25 mm (1 in.) hole saw. Remove any burrs from the edges of the holes.

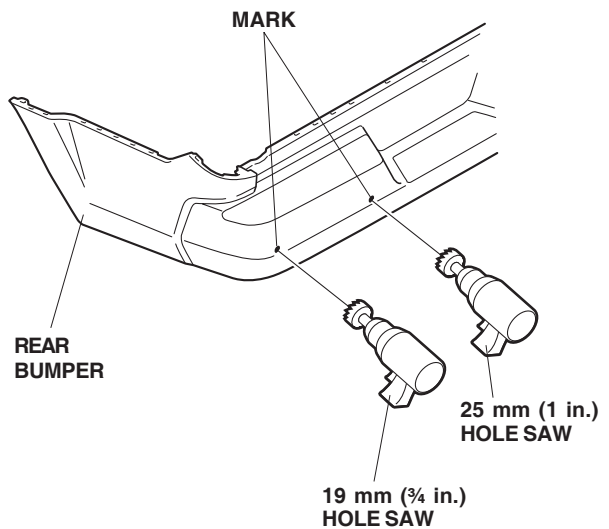

39. Repeat steps 37 and 38 to mark and drill the right side of the rear bumper.

Installing the Sensor

40. Separate the corner sensors from their trim. Install the corner sensor trim pieces into the 19 mm holes with the "UP" mark facing up, then install the corner sensors through the corner sensor trim pieces with the "UP" mark on the sensor facing up.

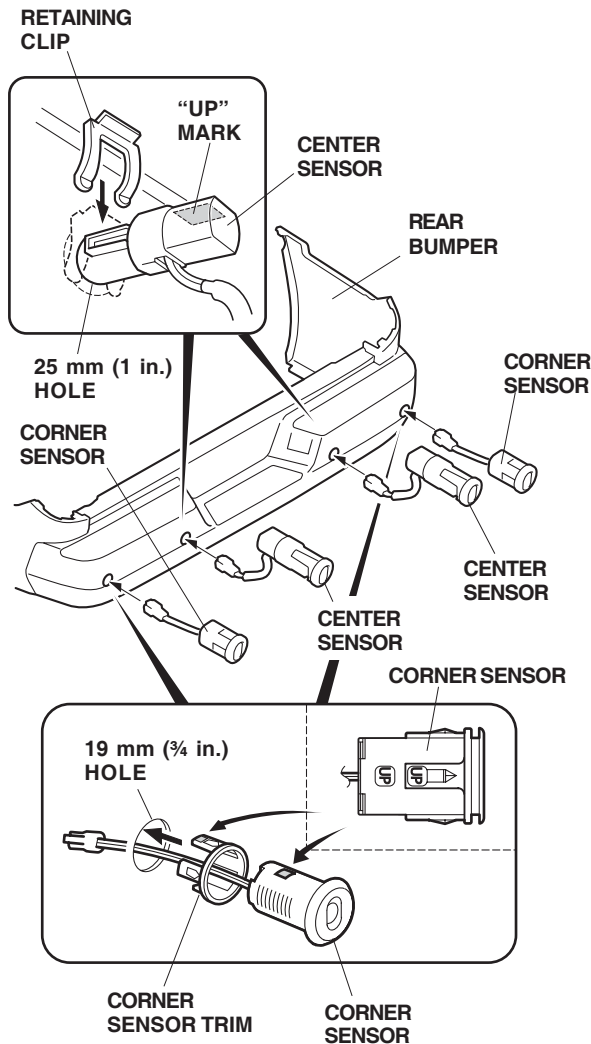

41. Slide the two center sensors into the 25 mm (1 in.) holes with the "UP" mark facing up. Secure the center sensors with one retaining clip for each sensor.

Cutting the Bumper Absorber

42. Remove the left and right bumper absorbers. Locate the scribe mark on the left bumper absorber. Using a utility knife, measure and cut out the left bumper absorber along the scribe mark.

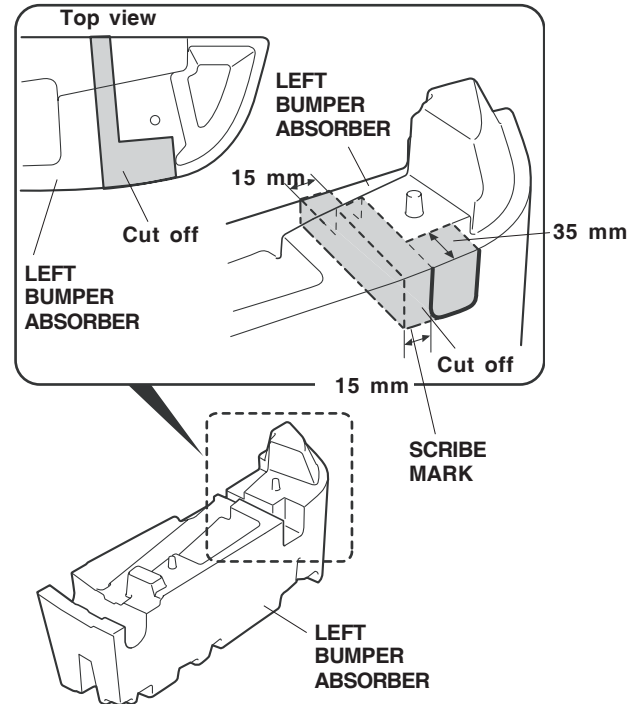

43. Repeat step 42 to cut the right bumper absorber.

Routing the Backup Sensor into the Passenger's Compartment

44. Get the backup sensor harness and fuse label. Attach the 2A fuse label to the backup sensor harness fuse case.

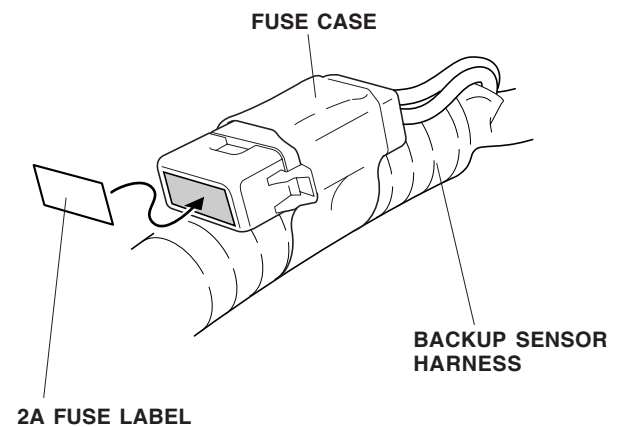

45. Inside the bed, remove the vehicle grommet from the vehicle panel.

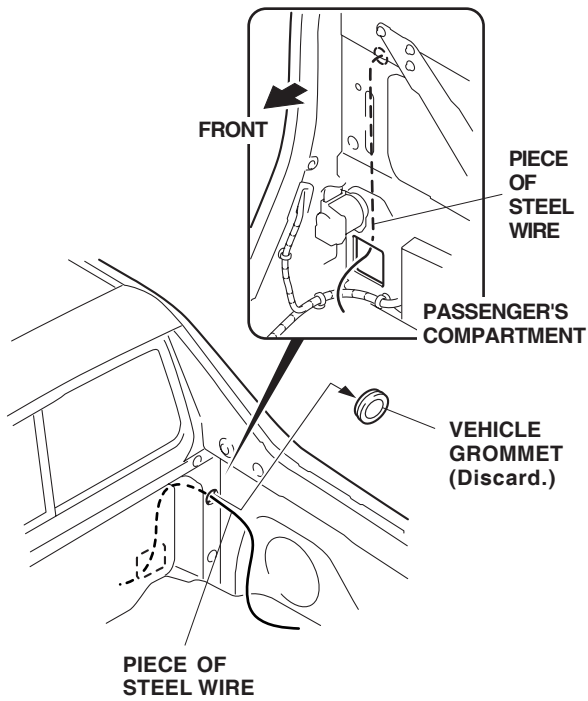

46. Insert a piece of steel wire into the empty grommet hole, and into the passenger's compartment.
47. From inside the passenger's compartment, attach the backup sensor harness 2-pin connector to the wire using electrical tape.

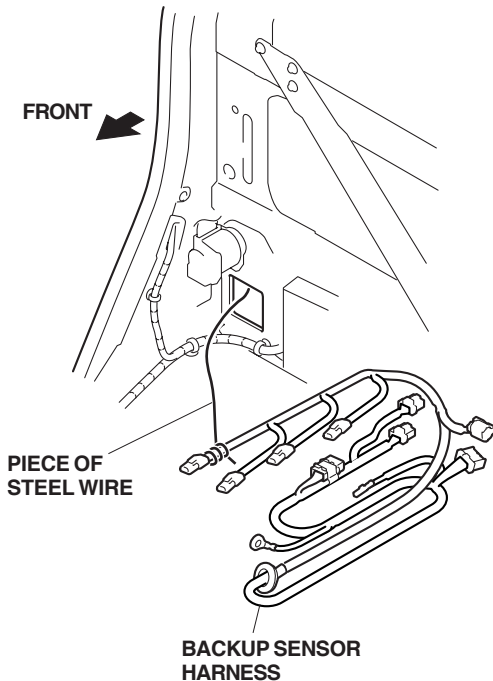

48. Pull the 2-pin connector up along the vehicle panel, and into the cargo area. Seat the backup sensor harness grommet into the body hole.

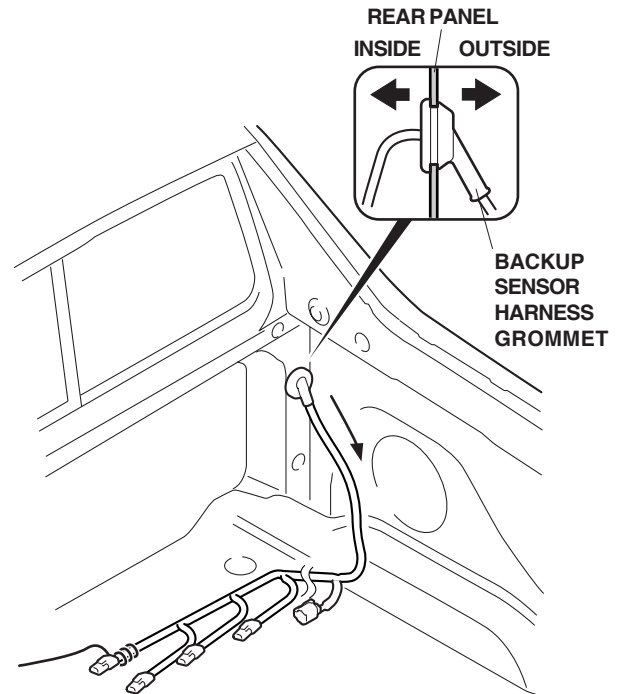

49. Inside the cargo area, route the backup sensor harness along the vehicle harness, and secure the front of the harness to the body with one white wire tie with clip.

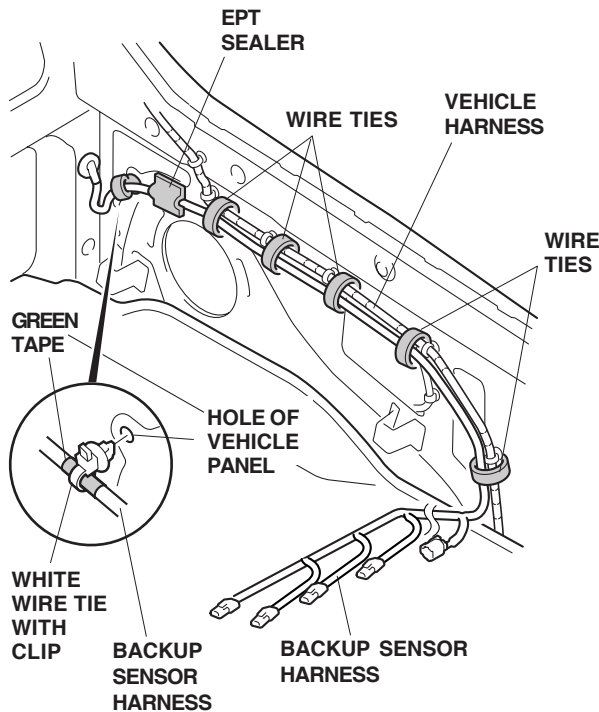

50. Secure the backup sensor harness to the vehicle harness with five wire ties in the area shown.
51. Clean the body with isopropyl alcohol on a shop towel near the front wire tie with clip, where the EPT sealer will attach. Secure the backup sensor harness to the vehicle panel with the EPT sealer.

52. Route the backup sensor harness along the vehicle harness, and through the left taillight opening. Secure the backup sensor harness to the vehicle harness with three wire ties.

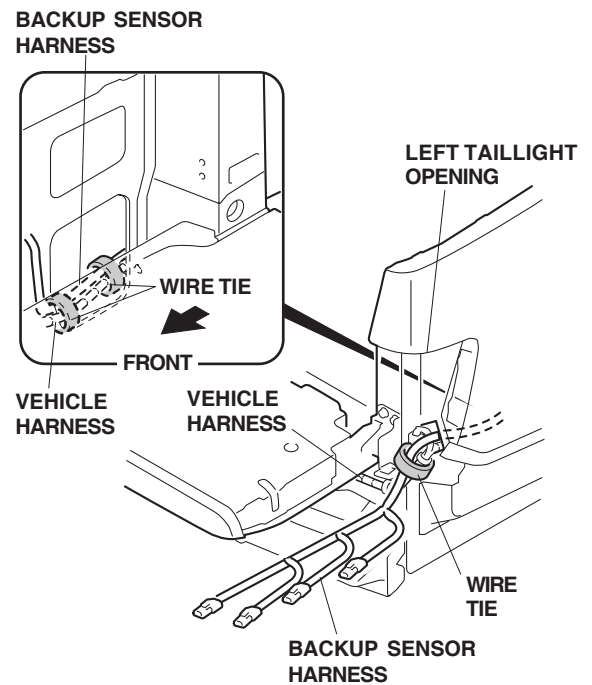

53. Continue routing the backup sensor harness along the rear bumper area, and secure it to the vehicle harness with eight wire ties.

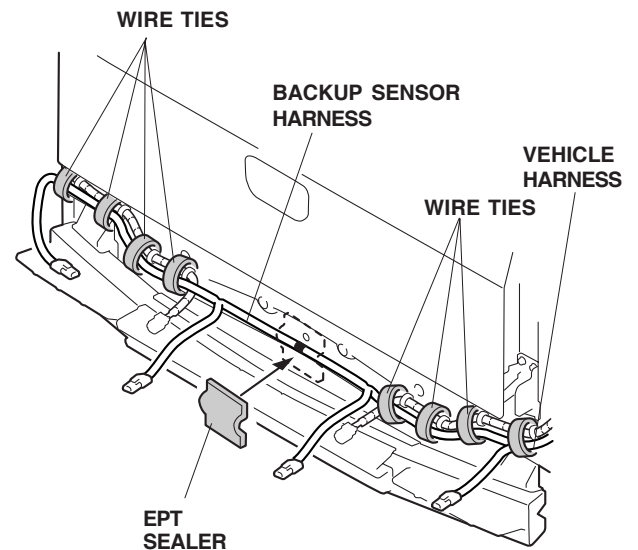

54. Using isopropyl alcohol on a shop towel, clean the area where the EPT sealer will attach. Secure the backup sensor harness to the vehicle panel with one EPT sealer at the green tape.

55. Using the scissors, cut one EPT sealer in half.

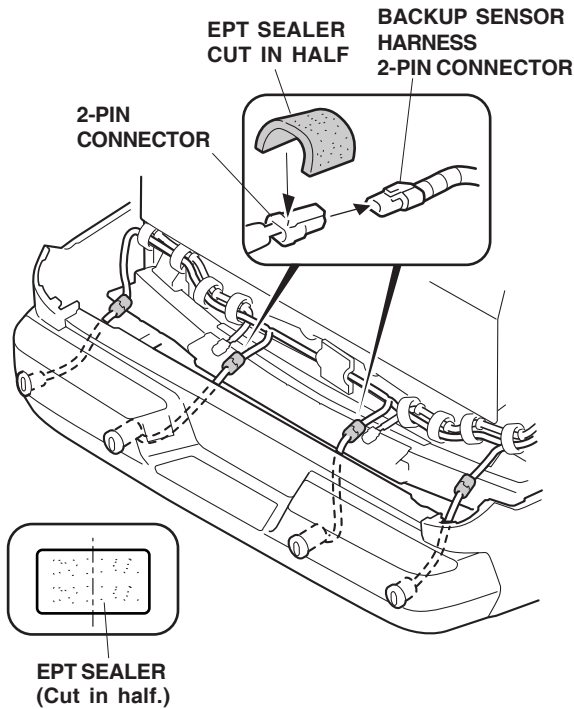

56. Reinstall the bumper absorbers. With the help of an assistant, hold the rear bumper close to the vehicle. Route the backup sensor harness 2-pin connector through the hole in the bumper absorber, connect the backup sensor harness 2-pin connectors to the corner sensor and center sensor 2-pin connectors. Wrap the pieces of cut EPT sealer around the center sensor 2-pin connectors, and reinstall the rear bumper.

57. Under the rear bumper, secure the center sensor 2-pin connectors to the bumper beam with two white wire ties with clips.

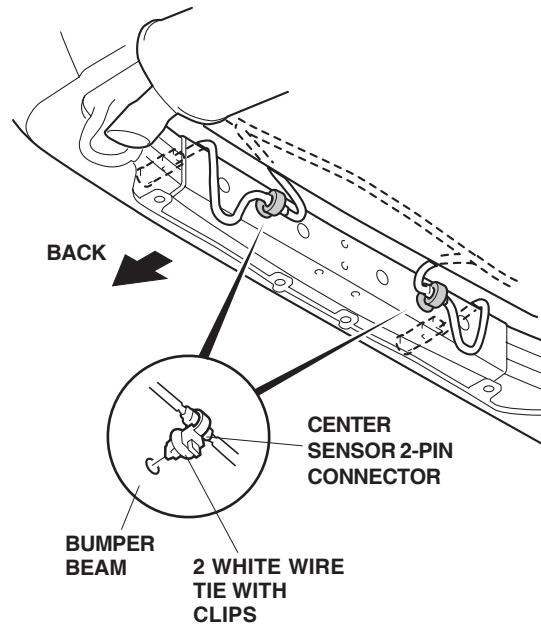

Installing the Tailgate Switch

58. At the tailgate latch, place a shop towel along the tailgate latch to catch any metal shavings. Attach adhesive tape inside the tailgate panel with the adhesive side up to catch any metal shavings.

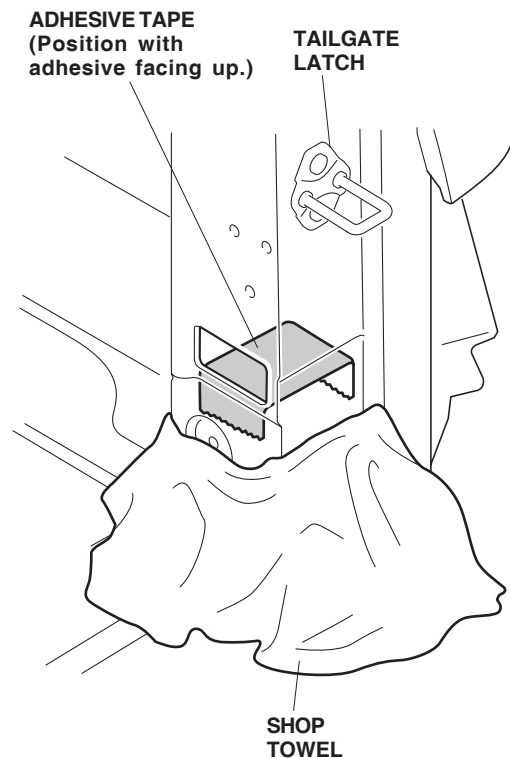

59. Position the template on the vehicle frame. Using a center punch, mark the vehicle frame at each of the five holes indicated on the template. Remove the template.

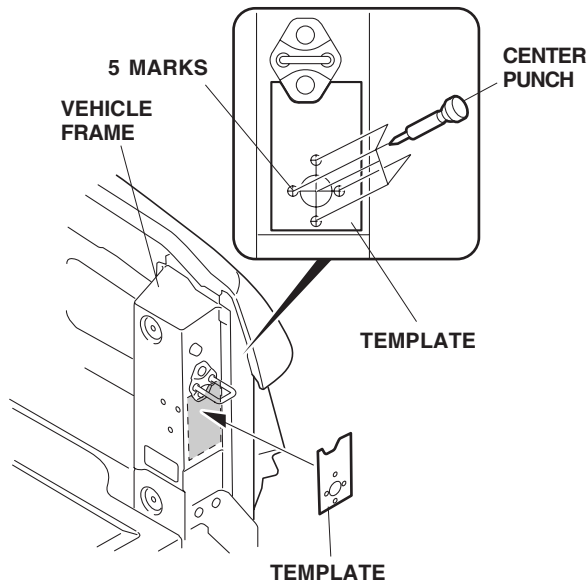

60. While wearing gloves and eye protection, drill a 26 mm hole and four 8 mm holes through each of the marked locations. First drill with a 3 mm drill bit, then finish the center hole with a 26 mm hole saw and the outer holes with an 8 mm drill bit.

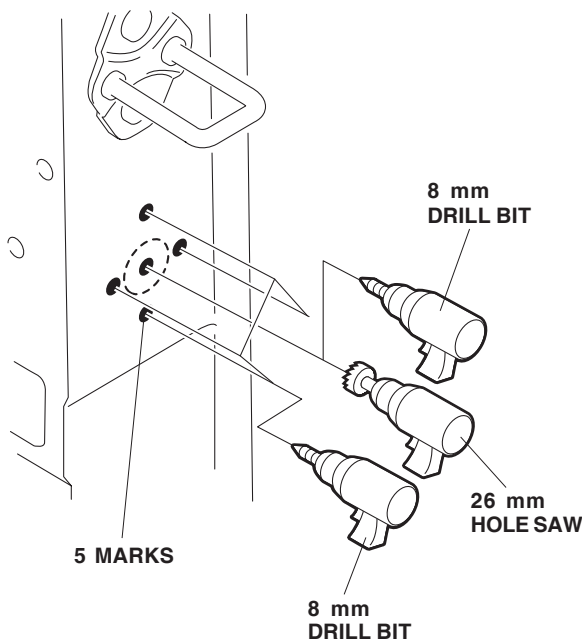

61. Remove any burrs from the edges of holes, and apply touch-up paint to the edges. Allow the touch-up paint to dry thoroughly before proceeding to the next step. Remove the shop towel, tape and remove any metal shavings.

62. Insert one blind nut into the upper and lower 8 mm holes.

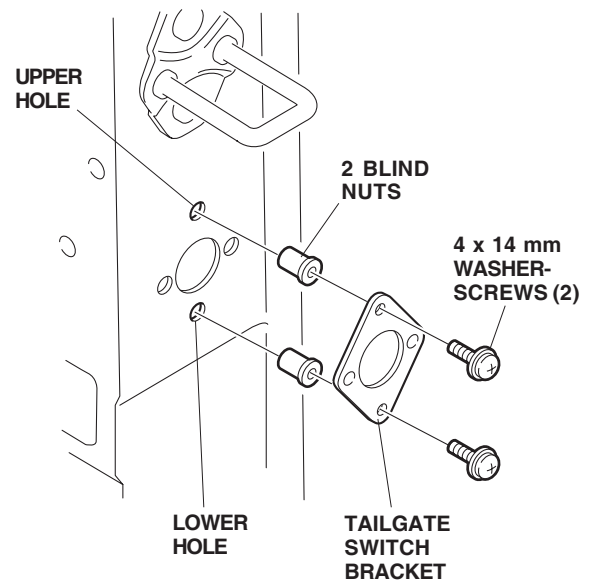

63. Install the tailgate switch bracket to the vehicle with two 4 x 14 mm washer-screws.
64. Get the tailgate switch and the corrugated tube, Cut 50 mm from the end of the corrugated tube. Wrap the corrugated tube around the wires of the tailgate switch, and secure the tube to the switch with electrical tape.

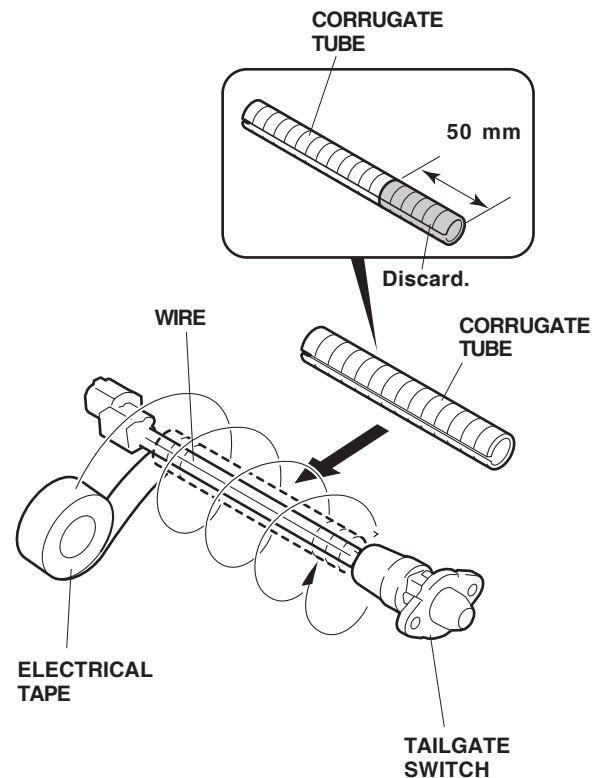

65. Insert the tailgate switch 2-pin connector into the 26 mm hole, and install the tailgate switch onto the tailgate switch bracket with the two 4 x 14 mm washer-screws.

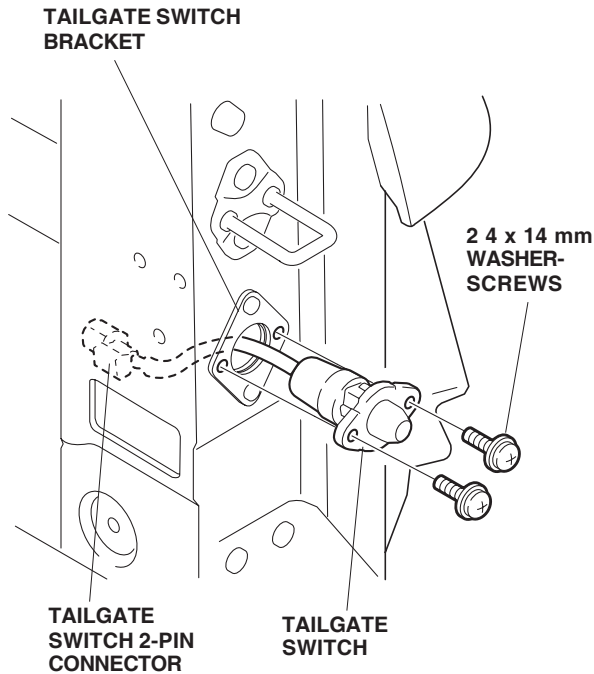

66. Plug the backup sensor harness 2-pin connector into the tailgate switch 2-pin connector.

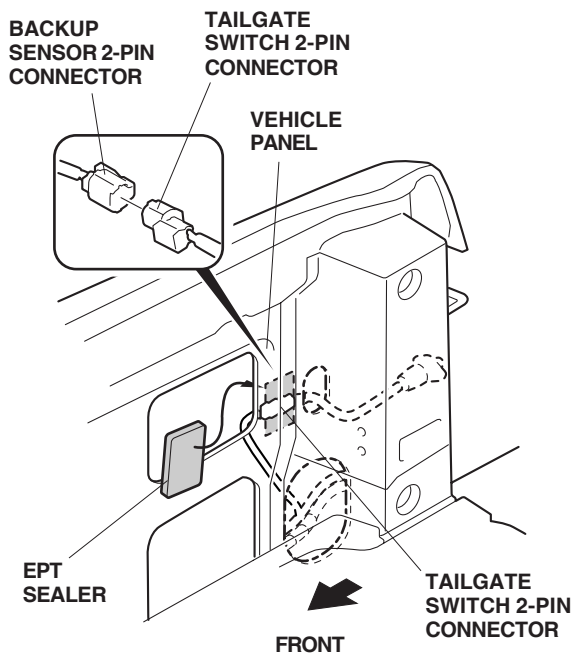

67. Using isopropyl alcohol on a shop towel, clean the areas where the EPT sealer will attach. Secure the backup sensor harness to the vehicle frame with one EPT sealer.

Routing the Backup Sensor Harness Inside the Passenger's Compartment

68. Pull back the floor mat, and route the backup sensor harness across the vehicle panel and alongside the vehicle harness.

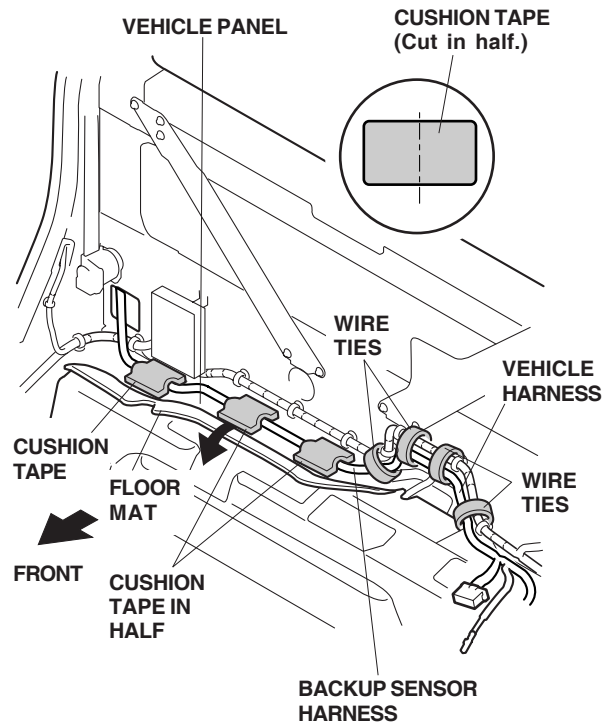

69. Using scissors, cut two cushion tapes in half. Using isopropyl alcohol on a shop towel, clean the areas where the cushion tapes will attach. Secure the backup sensor harness to the vehicle panel with three half cushion tapes.
70. Continue to secure the backup sensor harness to the vehicle harness with four wire ties. Do not secure it to the SRS harness.

71. Get the control unit and unit bracket. Slide the control unit bracket onto the control unit.

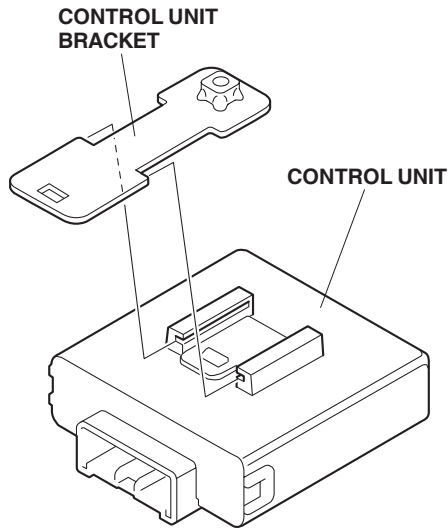

72. Plug the backup sensor harness 22-pin connector into the control unit, and insert the control unit bracket into the hole in the rear vehicle panel. Secure the control unit bracket with one flange nut.

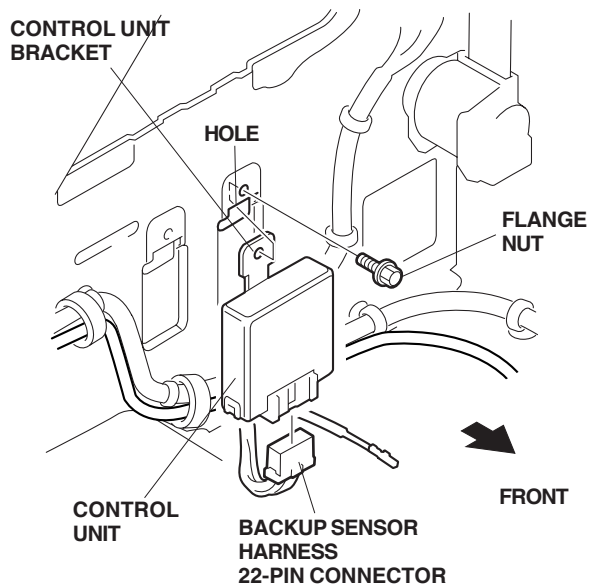

73. Unplug the vehicle 23-pin and 14-pin connectors. Release the connector lock on the vehicle 23-pin connector.

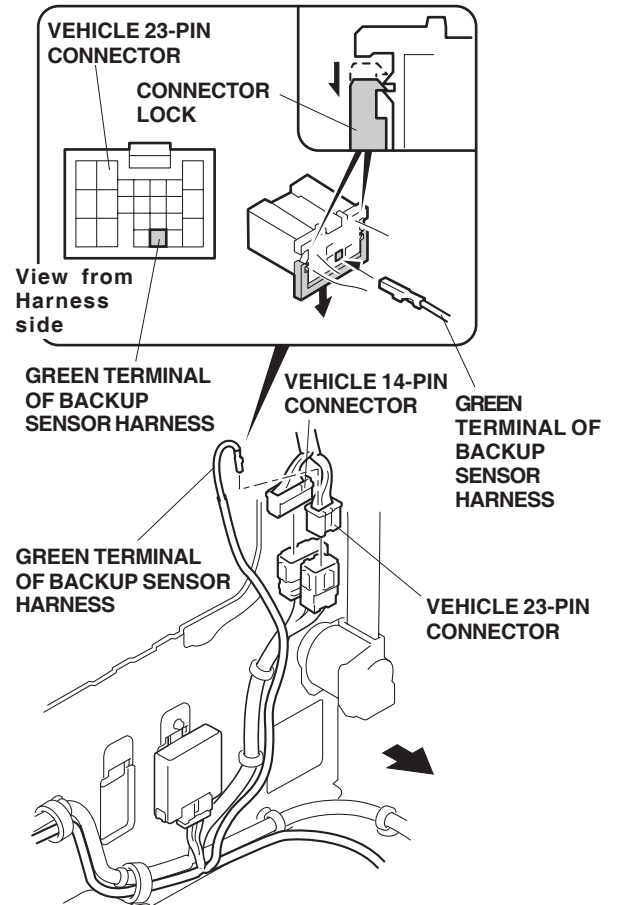

74. Push the green terminal from the backup sensor harness into vehicle 23-pin connector, then reattach the connector lock. Reconnect the vehicle 23-pin and 14-pin connectors.

75. Route the backup sensor harness forward. Secure the backup sensor harness to the vehicle harness with four wire ties and two small wire ties in the area shown.

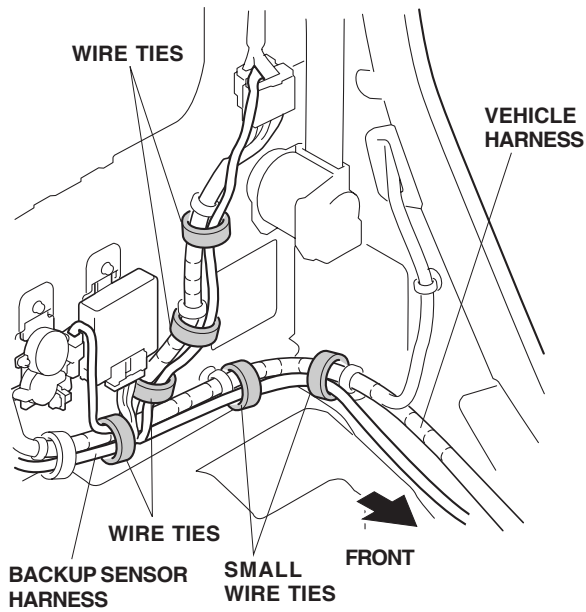

76. Route the backup sensor harness forward along the vehicle harness, and secure the backup sensor harness to the vehicle harness with four small wire ties.

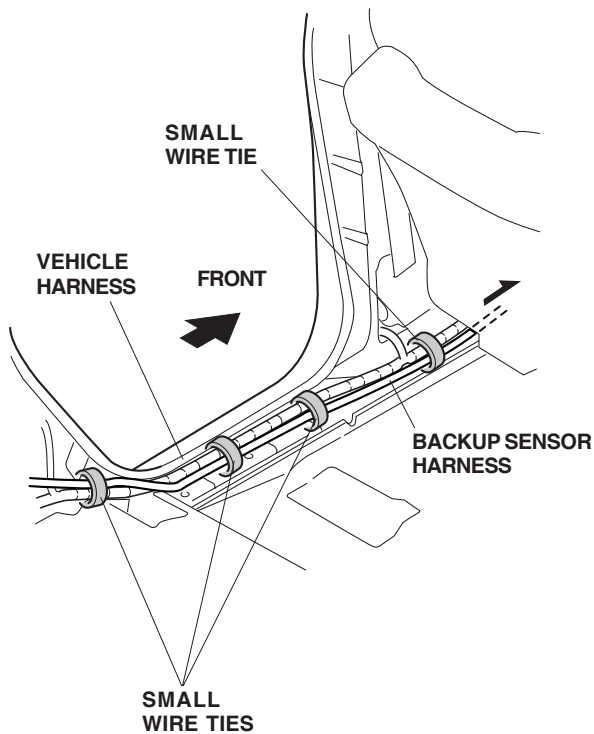

77. Continue routing the backup sensor harness along the vehicle harness, and secure it to the vehicle harness with three small wire ties.

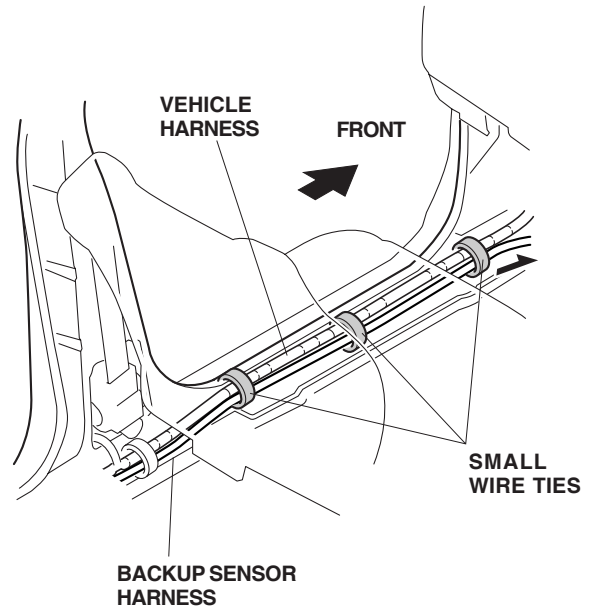

78. At the fuse box area, remove and discard the upper hood opener bolt. Attach the backup sensor harness ground terminal with the ground bolt from the kit.

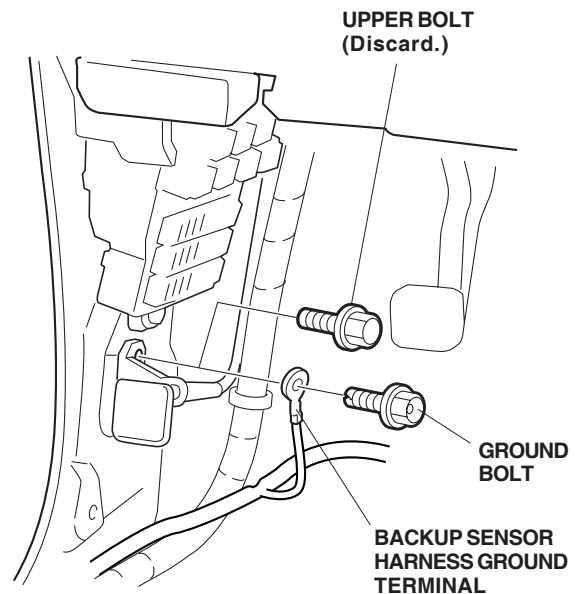

79. Route the backup sensor harness up and along the vehicle frame, and secure it to the vehicle harness and frame with five wire ties.

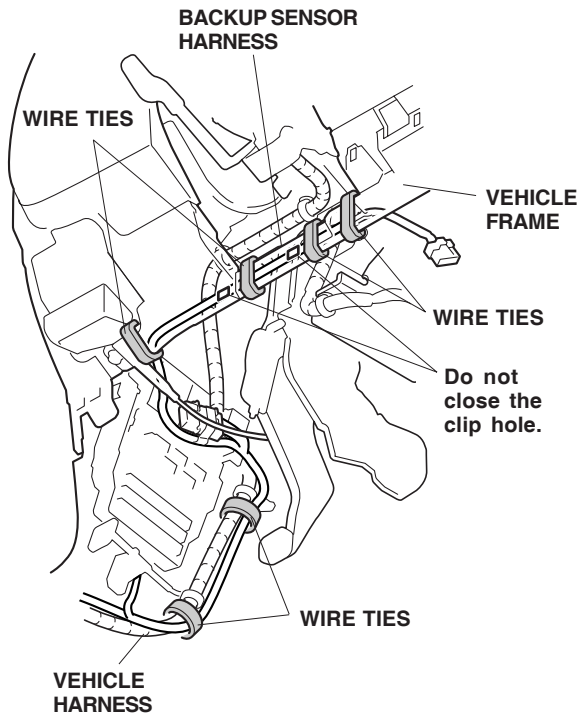

If the vehicle is equipped with a security system, wrap one cushion tape around the backup sensor harness, and secure the backup sensor harness to the security system bracket with the wire tie.

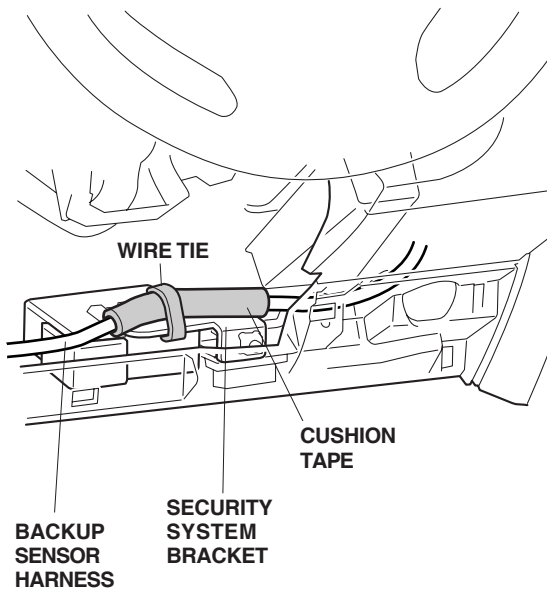

80. Continue routing the backup sensor harness down along the vehicle harness, and secure it to the vehicle harness and frame with three wire ties.

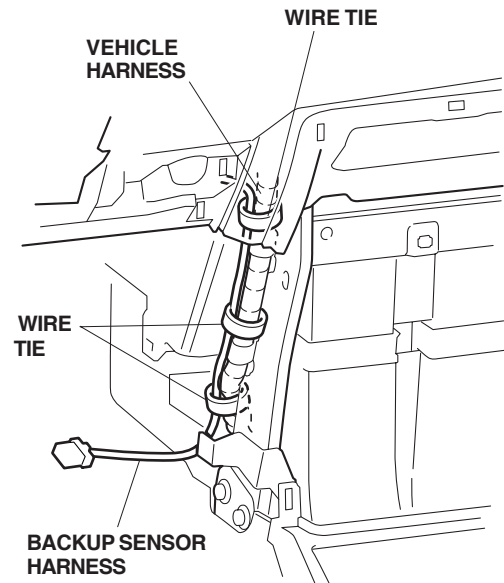

81. Install the buzzer bracket to the buzzer with one washer-bolt and flange nut. Take care not to pinch the wire.

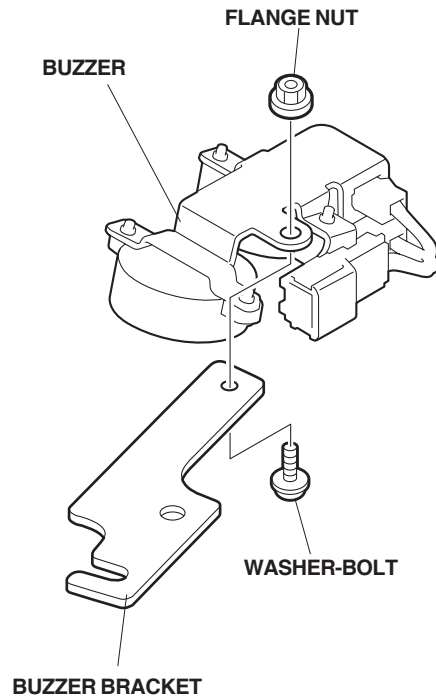

82. Remove the front vehicle bolt that fastens the vehicle frame, and loosen the back vehicle bolt,

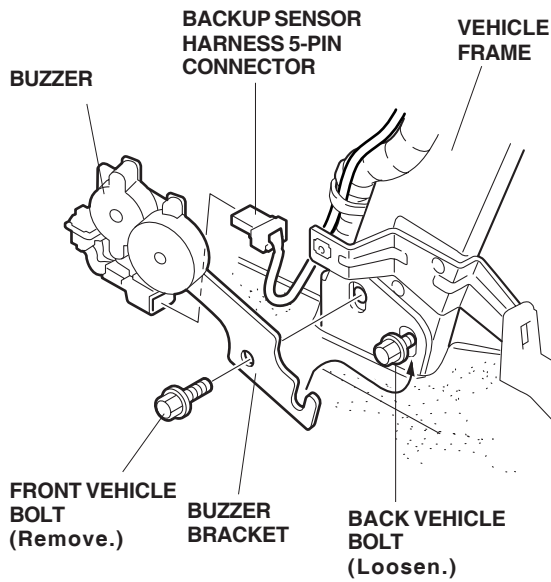

83. Plug the backup sensor harness into the buzzer.
 84. Insert the buzzer bracket between the vehicle frame and back bolt, and install the buzzer bracket to the vehicle frame. Tighten the bolts.

Installing the switch

85. Using a pushpin, mark the inside of the driver's dashboard lower cover at the preset mark.

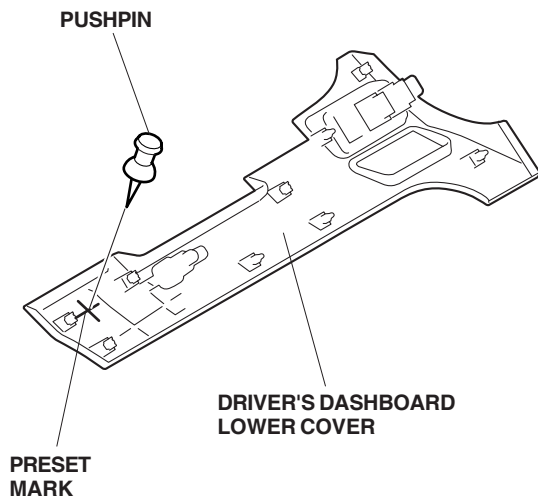

86. While wearing eye protection, drill a 26 mm hole through the marked position. First drill with a 3 mm drill bit, then finish with a 26 mm hole saw. Remove all burrs.

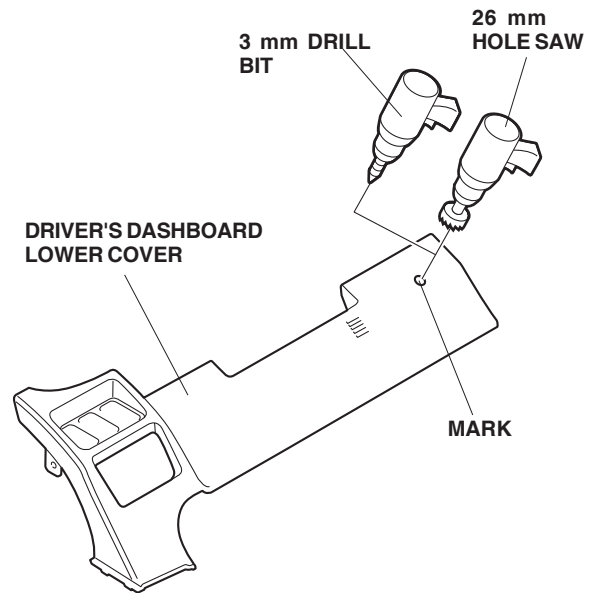

87. Reinstall the driver's dashboard lower cover. Insert the switch connector into the hole of the dashboard lower cover, then turn the switch to install it to the dashboard lower cover.

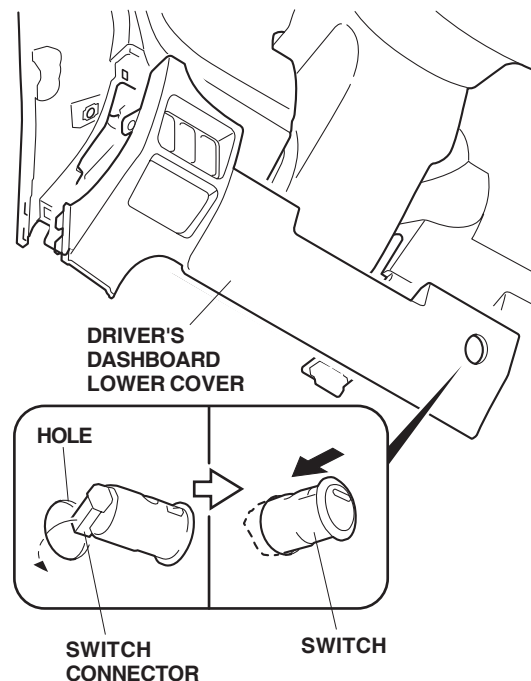

88. Plug the backup sensor harness 3-pin connector into the switch.

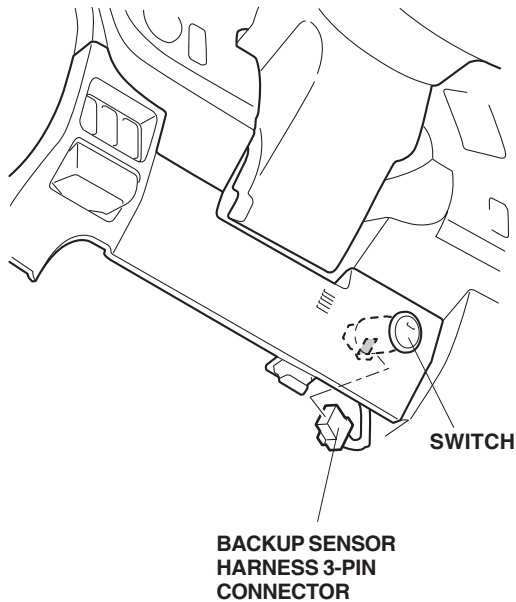

89. Using isopropyl alcohol on a shop towel, clean the areas where the EPT sealer will attach. Attach the EPT sealer to the driver's console side trim in the area shown.

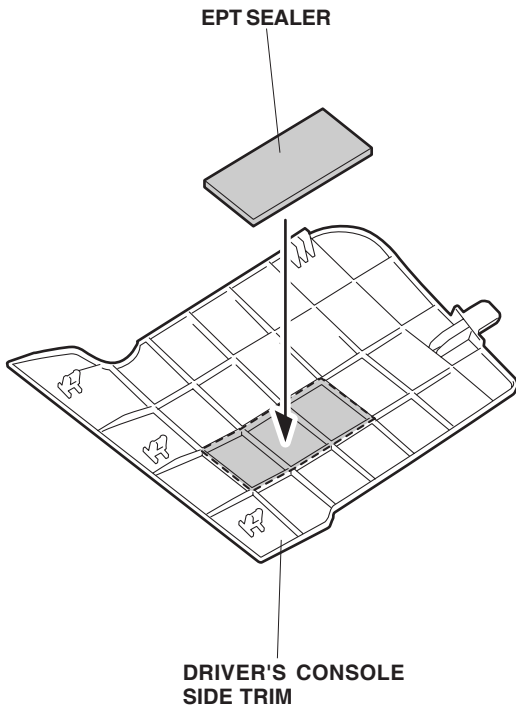

90. Check that all wire harnesses and cables are routed properly and that all connectors are plugged in.
91. Reconnect the negative cable to the battery. Check the brake light operation and the back window open indicator function. The back window open indicator turns on when the back window is open and the ignition is turned off. If a malfunction is found, check for soft set terminal pins of the connectors used in step 73.
92. Reinstall all removed parts. Check that all clips and fasteners are installed securely.
93. Enter the customer's radio anti-theft code, and reset the radio station presets,
94. Reset the clock.
95. Check the operation of the automatic backup sensor according to the Information Manual supplied.

NOTE: Whenever the battery is disconnected, the driver's AUTO function is disabled.

96. Start the engine. Push down on the driver's window switch until the window is fully open.
97. Pull up on the driver's window switch fully to close the window completely, then hold the switch for 2 seconds or more.
98. Test the window AUTO function.