



# INSTALLATION INSTRUCTIONS

Accessory

**FRONT LOWER TRIM  
P/N 08P01-S9V-110B**

Application

**2008 PILOT**

Publications No.

**All 37165**

Issue Date

**JUNE 2007**

## PARTS LIST

Front lower trim

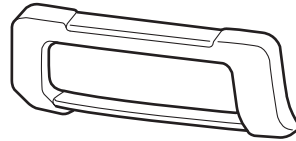

Washer-nut, 6 mm



6 Screws, 6 x 12 mm



6 Plain-washers, 6 mm



## TOOLS AND SUPPLIES REQUIRED

Phillips screwdriver

Flat-tip screwdriver

Ratchet

10 mm Socket

10 mm Combination wrench

Hacksaw blade

Drill

3 mm and 12 mm Drill bits

File

Masking tape

Blanket

Push-pin

## INSTALLATION

**Customer Information:** The information in this installation instruction is intended for use only by skilled technicians who have the proper tools, equipment, and training to correctly and safely add equipment to your vehicle. These procedures should not be attempted by "do-it-yourselfers."

**NOTE:** Be extremely careful not to damage the body paint finish.

1. Open the hood. Remove the front bulkhead cover (thirteen clips).

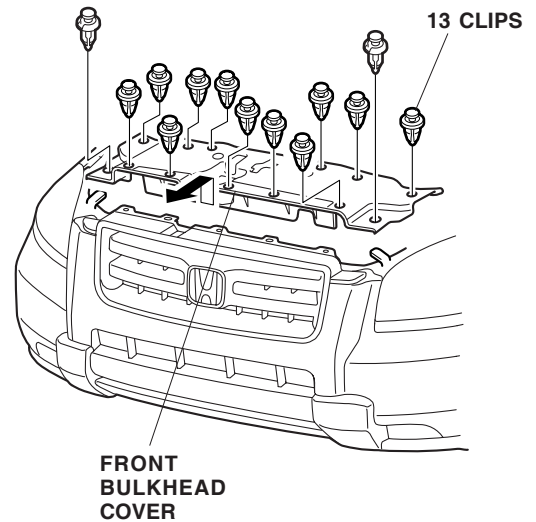

2. Remove the front bumper (five clips, two self-tapping screws and four bolts). To prevent damage, rest the bumper on a blanket.

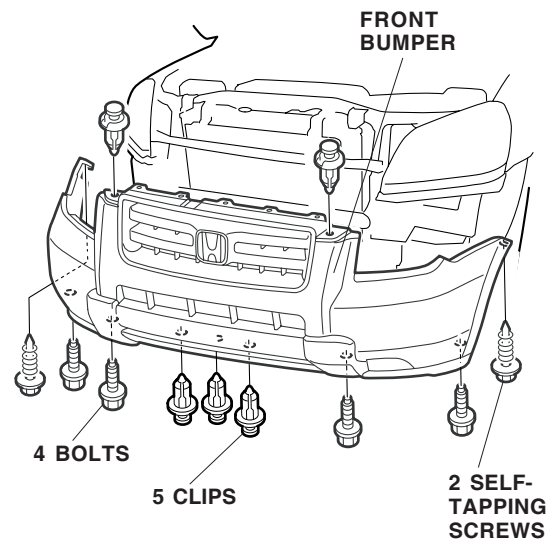

- From the lower inside edge of the front bumper, measure 110 mm upward, and from the notch in the bumper, measure 43 mm outward as shown. Use a push-pin to mark the location. Repeat on the other side.

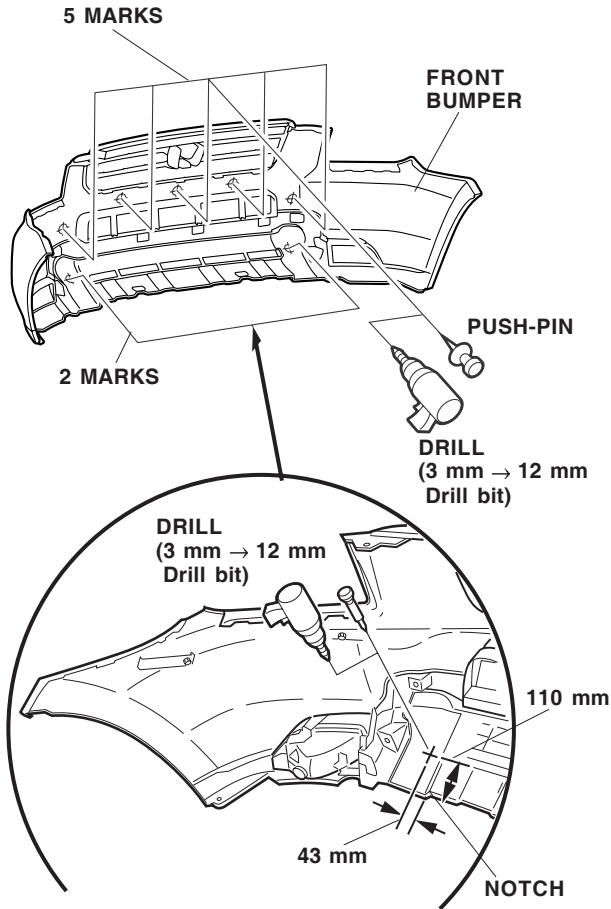

- Use a push-pin to mark the five locations shown.
- While wearing eye protection, drill a 12 mm hole through the seven marks on the front bumper.
  - First drill with a 3 mm drill bit, and finish with a 12 mm drill bit.
  - Remove any burrs from the edges of the holes with a file.

- Insert the stud from the front lower trim into the hole in the front bumper as shown.

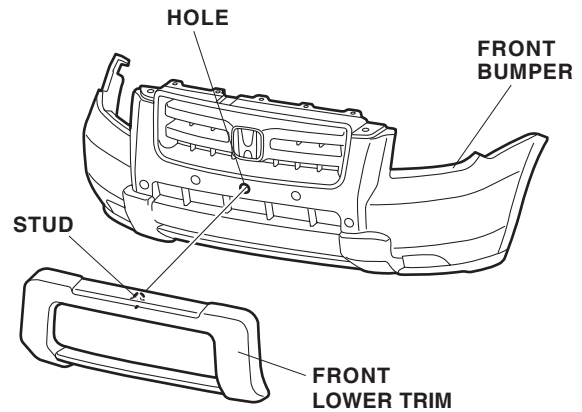

- Secure the front lower trim to the front bumper with six 6 x 12 mm screws and six 6 mm plain-washers. Install the 6 mm washer-nut on the end of the stud, and tighten it securely.

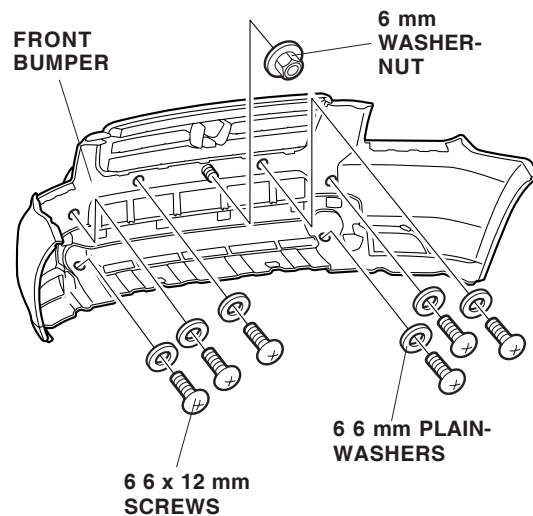

- Reinstall the front bumper. Make sure that all clips and retaining tabs are attached properly.