



INSTALLATION INSTRUCTIONS

Accessory	Application	Publications No.
FENDER FLARES	2008 PILOT	All 37161
		Issue Date JUNE 2007

PARTS LIST

Left front bumper flare

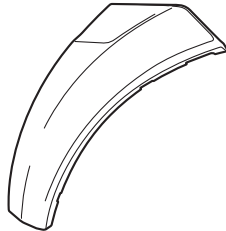

Left front fender flare

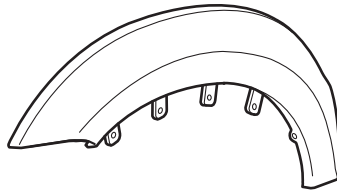

Left rear fender flare

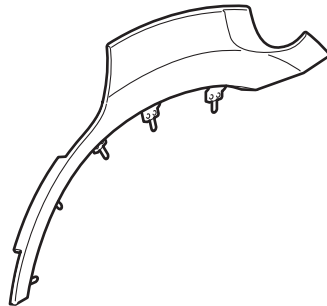

Left rear bumper flare



Left rear door flare

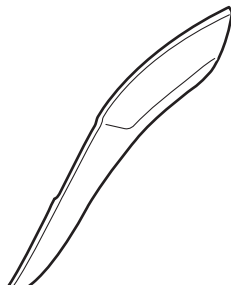

Right front bumper flare

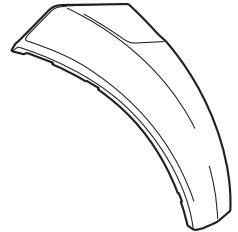

Right front fender flare

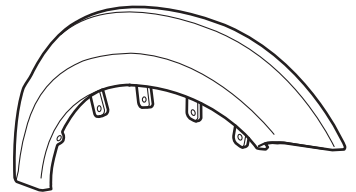

Right rear fender flare

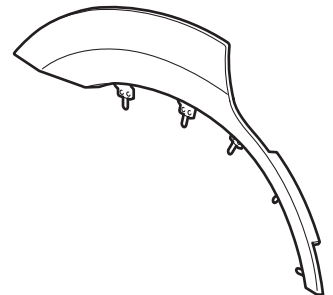

Right rear bumper flare

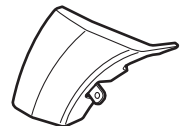

Right rear door flare

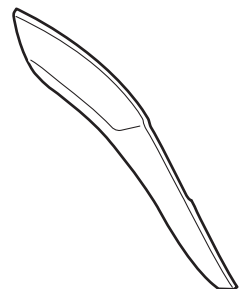

6 Self-tapping screws



4 Spring nuts



4 Clips



10 Alcohol pads

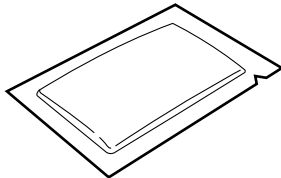

TOOLS AND SUPPLIES REQUIRED

Stubby Phillips screwdriver

Phillips screwdriver

Flat-tip screwdriver

Ratchet

10 mm Combination wrench

Shop towel

Masking tape

Clip remover

Hard rubber roller

Felt-tip pen

INSTALLATION

Customer Information: The information in this installation instruction is intended for use only by skilled technicians who have the proper tools, equipment, and training to correctly and safely add equipment to your vehicle. These procedures should not be attempted by “do-it-yourselfers.”

NOTE:

- This fender flare kit cannot be installed on a vehicle equipped with a full nose mask.
- Be careful not to damage the finished surfaces of the body when installing the fender flares.
- This fender flare kit should be installed only when the ambient air temperature is 60°F (15°C) or above.
- To allow the adhesive to “cure,” do not wash the vehicle for 24 hours.
- These instructions show the left fender flares being installed; the same procedure applies to installing the right fender flares.

Installing the Front Bumper Flare

1. Align the ends of the front bumper flare with the back edge of the front bumper. Using a felt-tip pen, mark the edge of the front bumper through the two holes in the bumper flare. Remove the front bumper flare.

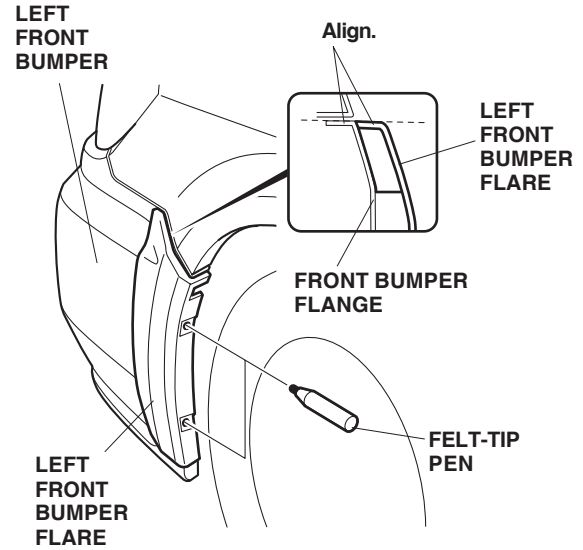

2. Pierce the left front bumper with a self-tapping screw at the marks. Remove the screw then slide one spring nut over each of the two holes you made in the front bumper.

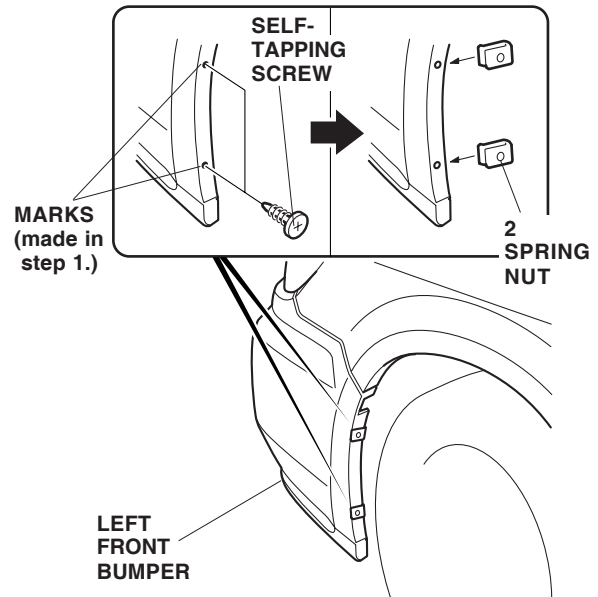

3. Using an alcohol pad, clean the front bumper where the front bumper flare will attach.

- On the inside of the left front bumper flare, pull back 3 to 5 cm (1 to 2 in.) from each adhesive backing. Fold the ends back, and tape them to the front of the bumper flare.

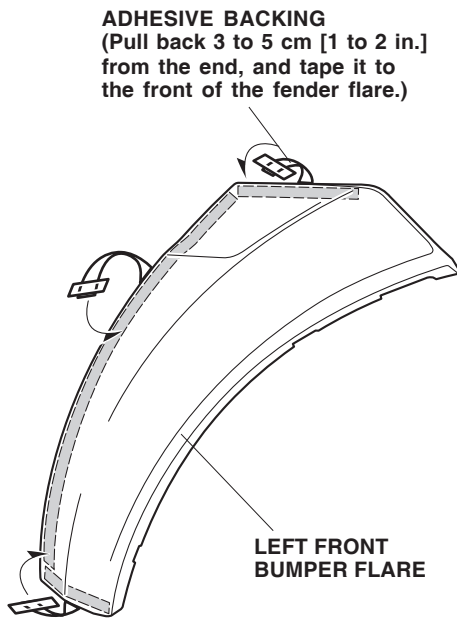

- Position the left front bumper flare on the front bumper and install the two self-tapping screws (from the kit) through the front bumper. Do not tighten the self-tapping screws yet.

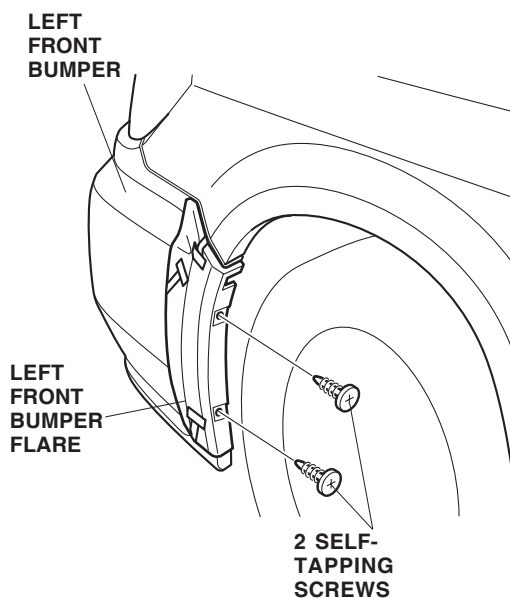

- Remove the adhesive backings from the left front bumper fender flare:
 - Slowly and carefully peel the adhesive backing from the left front bumper flare.
 - After removing all of the adhesive backings, press the left front bumper flare firmly against the front bumper with the palm of your hand for 30 seconds, particularly at the edges. Make sure to apply enough pressure to ensure the adhesive tape sticks to the body.

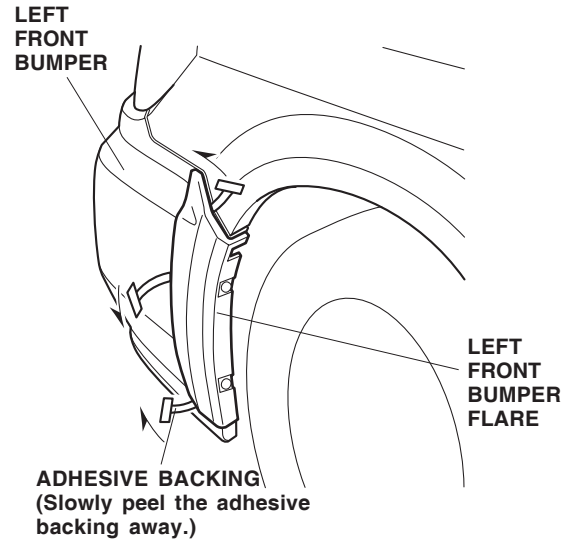

- Tighten the two self-tapping screws.

Installing the Front Fender Flare

- Remove the five expansion clips from the left front inner fender.

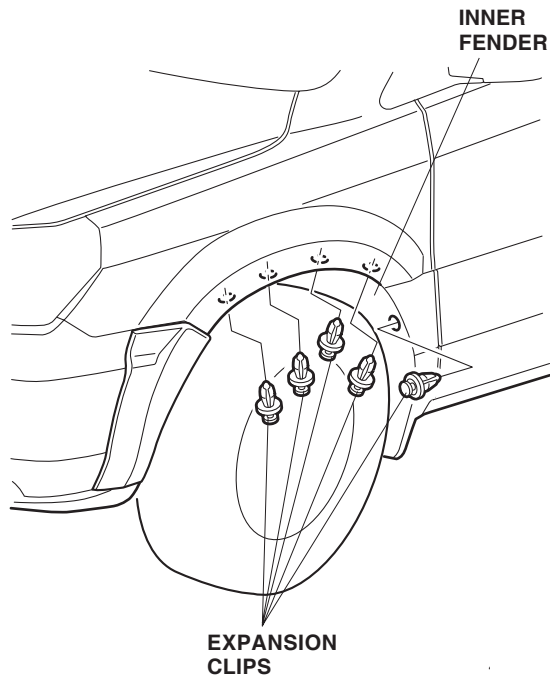

- Using an alcohol pad, clean the front bumper where the front fender flare will attach.

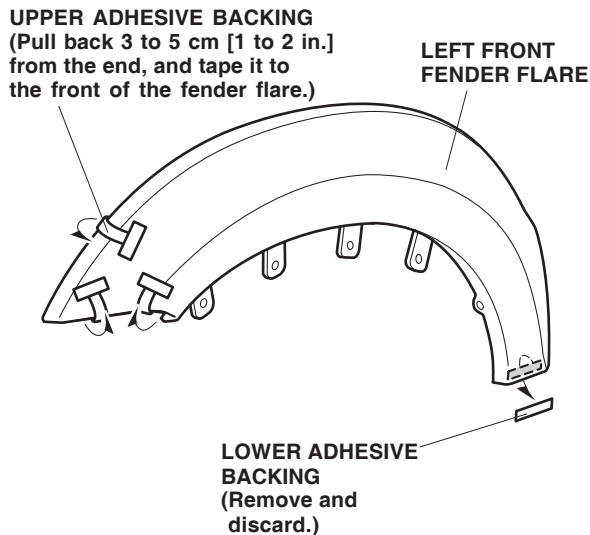

- On the inside of the left front fender flare, pull back 3 to 5 cm (1 to 2 in.) from the upper and front adhesive backings. Fold the ends back, and tape them to the front of the fender flare. Remove and discard the two lower adhesive backings.

- Align the ends of the front fender flare with the front edge of the front fender, and bend the mounting tabs around the fender flange.

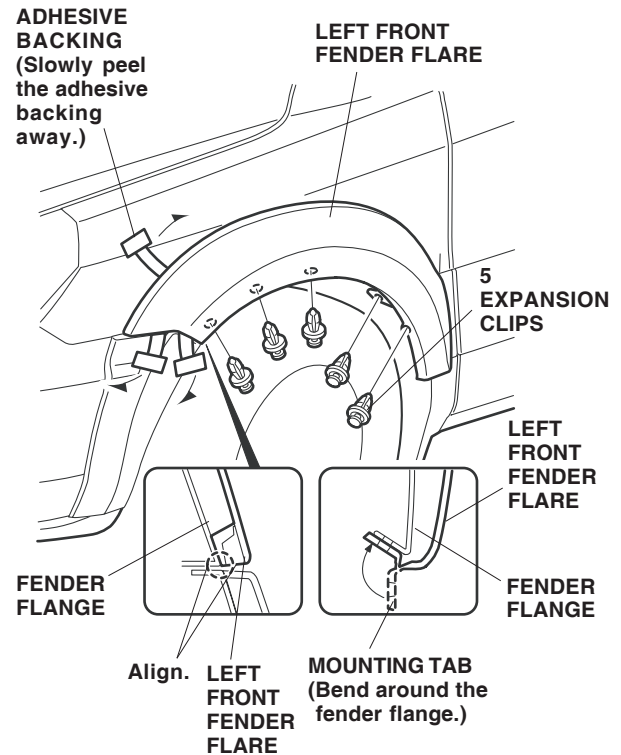

- Install the five expansion clips through the holes in the fender flare and fender flange.

- Remove the adhesive backings from the fender flare:

- Start with the front adhesive backing.
- Slowly and carefully peel the adhesive backing from the fender flare.
- After removing the adhesive backing, press the fender flare firmly against the fender with the palm of your hand for 30 seconds, particularly at the edges. Make sure to apply enough pressure to ensure the adhesive tape sticks to the body.

Installing the Rear Fender Flare

14. Remove the molding from the inner fender flange.

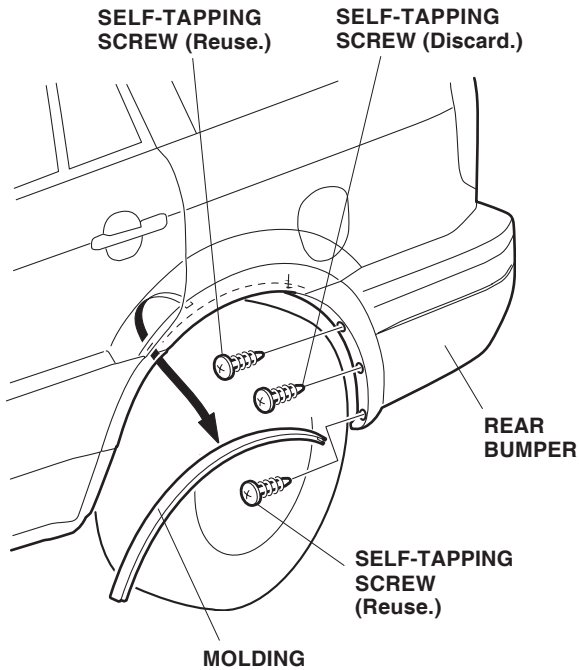

15. Remove the two self-tapping screws that fasten the rear bumper.
16. Remove the eight bolts, two expansion clips and one self-tapping screw that secure the inner fender. Rest the inner fender on the rear tire.

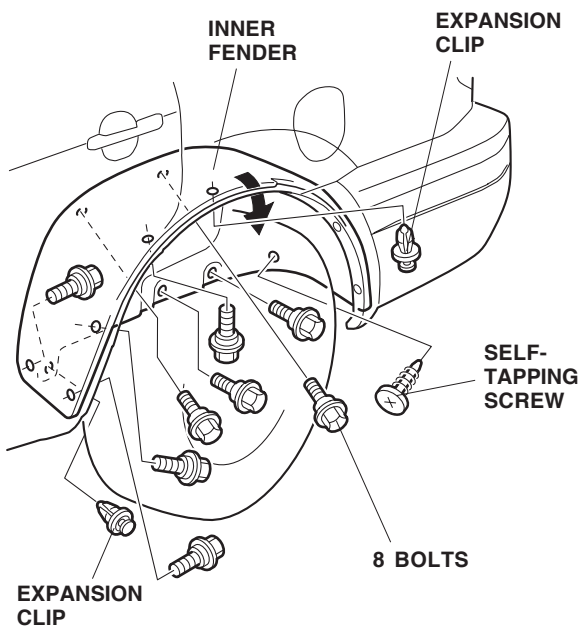

17. Remove the rear fender trim by separating the double-sided tape and pulling the trim down.

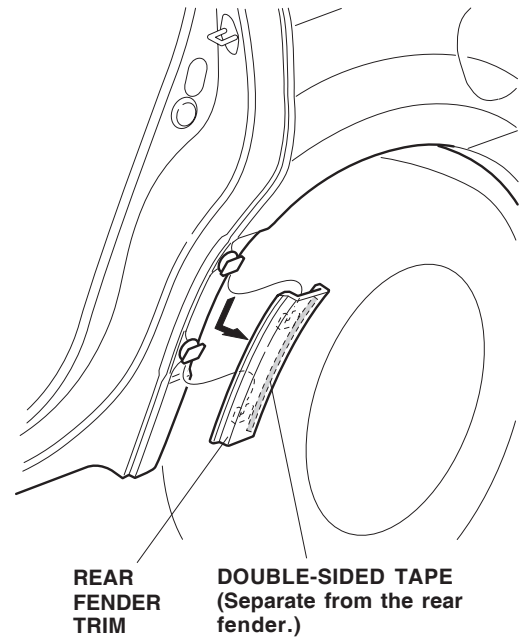

18. Remove and discard the two clips from the rear fender.



- Using an alcohol pad, clean the rear fender where the rear fender flare will attach.

ADHESIVE BACKING
(Pull back 3 to 5 cm [1 to 2 in.] from the end, and tape it to the front of the fender flare.)

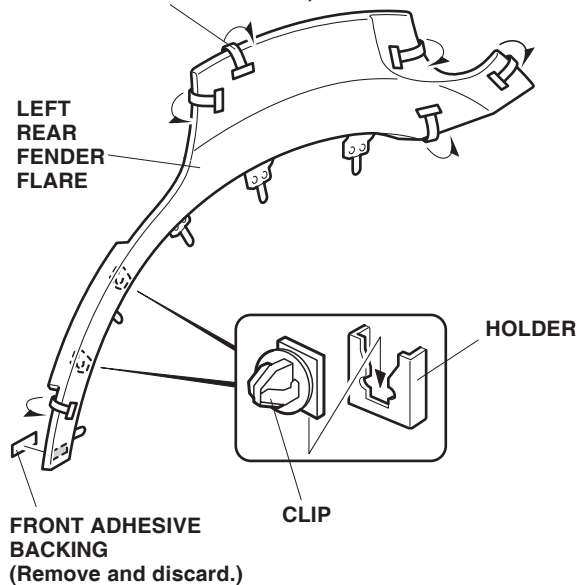

- On the inside of the left rear fender flare, pull back 3 to 5 cm (1 to 2 in.) from each adhesive backing. Fold the ends back, and tape them to the front of the fender flare. Remove and discard the front adhesive backing.
- Slide one clip into each holder on the rear fender flare.

- Position the rear fender flare on the rear fender, and align it with the rear ends of the rear fender and fuel door. Bend the mounting tabs around the fender flange.

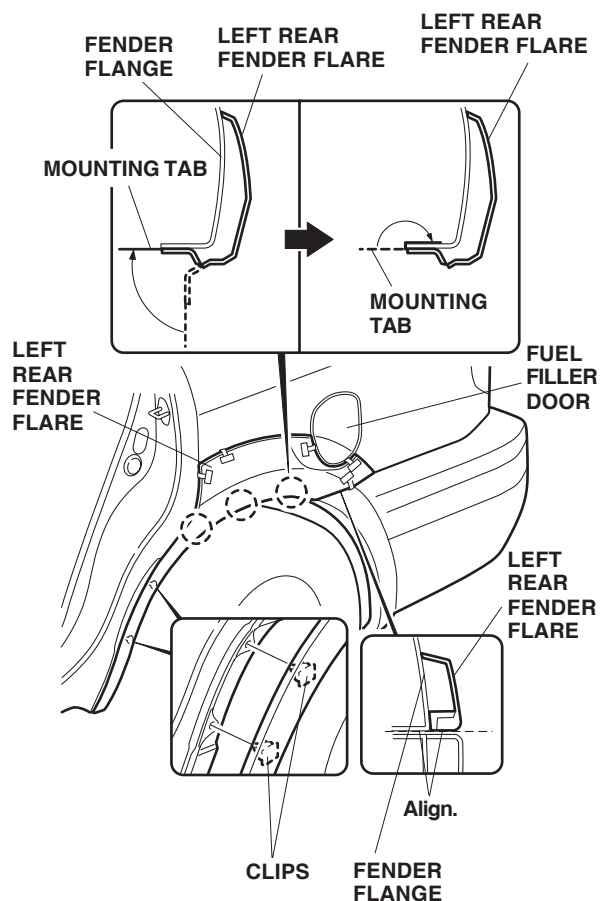

- Verify that the fender flare clips line up with the holes in the vehicle body, then clip the fender flare into position.
- Open and close the fuel door to check that it does not interfere with the rear fender flare.

25. Remove the adhesive backings from the rear fender flare:
- Slowly and carefully peel the adhesive backing from the rear fender flare.
 - After removing all of the adhesive backings, press the rear fender flare firmly against the fender with the palm of your hand for 30 seconds particularly at the edges. Make sure to apply enough pressure to ensure the adhesive tape sticks to the body.

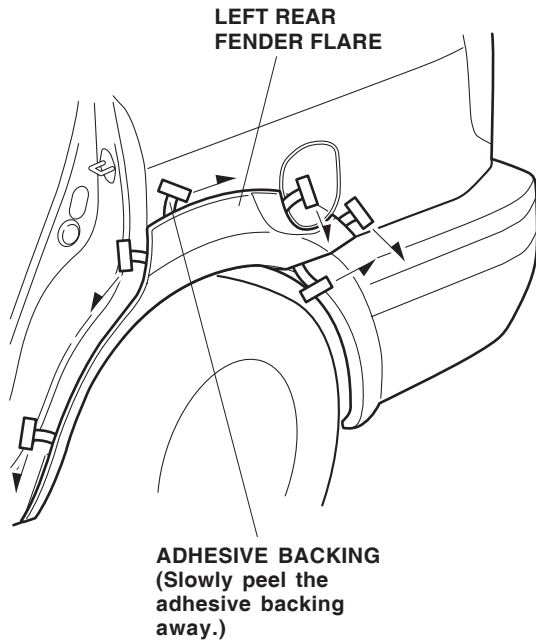

26. Reinstall the inner fender removed in step 16.
27. Reinstall the self-tapping screws removed in step 15. Do not install the middle self-tapping screw in the rear bumper at this time.

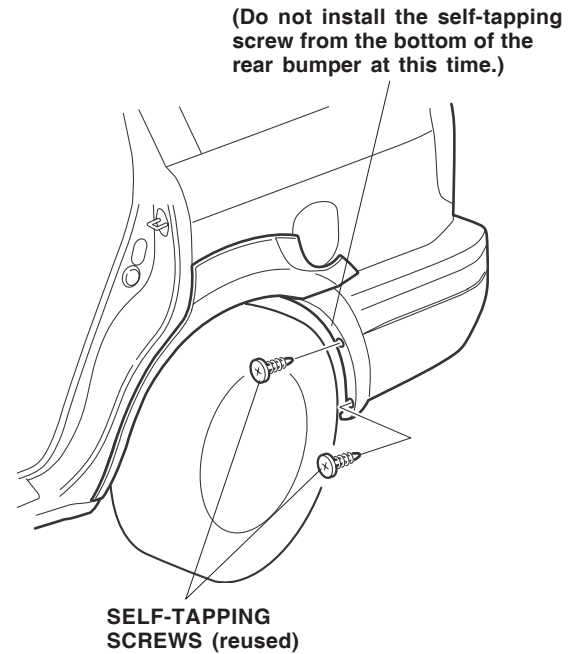

28. Reinstall the molding over the rear fender and fender flange.

Installing the Rear Bumper Flare

29. Using an alcohol pad, clean the rear bumper where the rear bumper flare will attach.

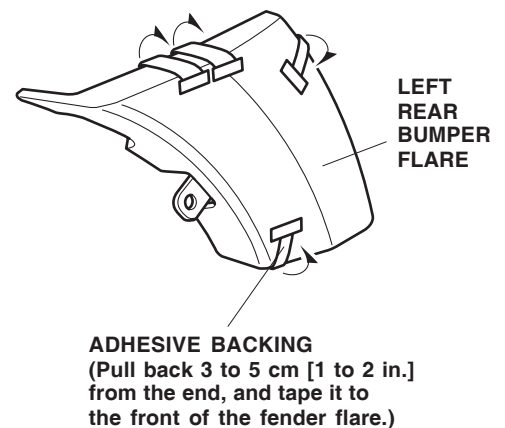

30. On the inside of the left rear bumper flare, pull back 3 to 5 cm (1 to 2 in.) from each adhesive backing. Fold the ends back, and tape them to the front of the bumper flare.

31. Position the rear bumper fender flare on the rear bumper, and align it with the upper edge of the rear bumper. Bend the mounting tabs around the fender flange, then install the new self-tapping screw, but do not tighten the screw at this time.

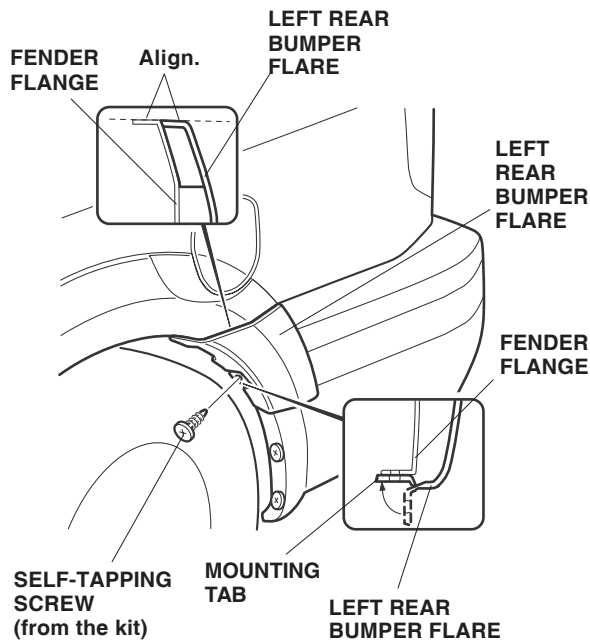

32. Remove the adhesive backings from the rear bumper flare:
- Slowly and carefully peel the adhesive backing from the rear bumper flare.
 - After removing all of the adhesive backings, press the rear bumper flare firmly against the bumper with the palm of your hand for 30 seconds, particularly at the edges. Make sure to apply enough pressure to ensure the adhesive tape sticks to the body.

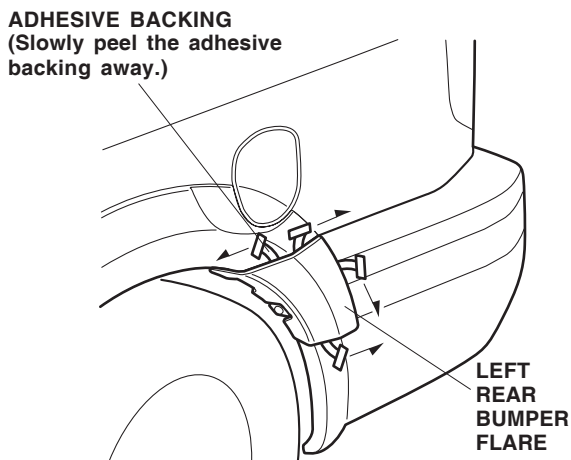

33. Tighten the three self-tapping screws .

Installing the Rear Door Flare

34. Using an alcohol pad, clean the door where the rear door flare will attach.

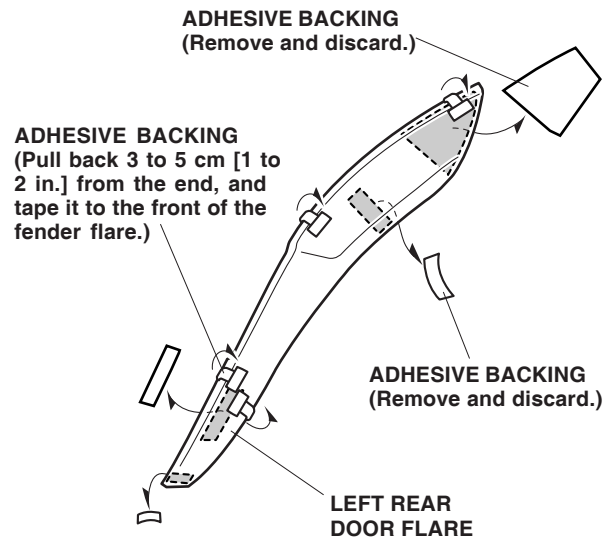

35. On the inside of the rear door flare, pull back 3 to 5 cm (1 to 2 in.) from each adhesive backing. Fold the ends back, and tape them to the front of the rear door flare. Remove and discard the four adhesive backings as shown.
36. Open the left rear door. Position the rear door flare on the rear door and align the side edge of the rear door flare with the side edge of the rear door. Adjust the rear door flare character lines to the character lines of the rear door.

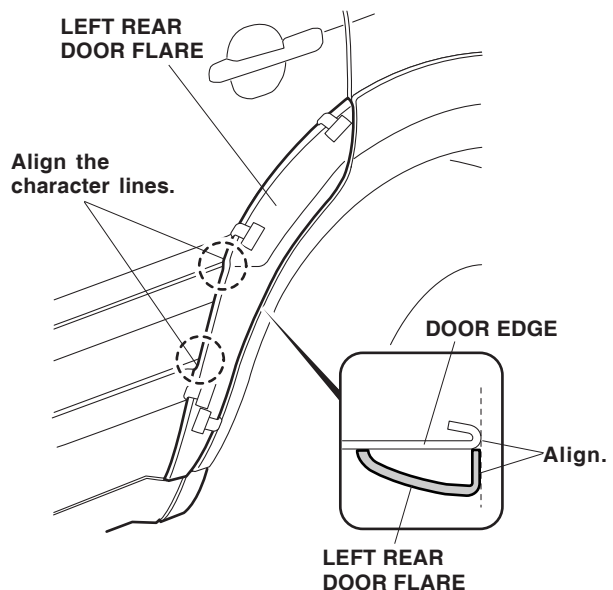

37. Remove the adhesive backings from the rear door flare:

- Slowly and carefully peel the adhesive backing from the rear door flare.
- After removing all of adhesive backings, press the rear door flare firmly against the rear door with the palm of your hand for 30 seconds particularly at the edges. Make sure to apply enough pressure to ensure the adhesive tape sticks to the body.

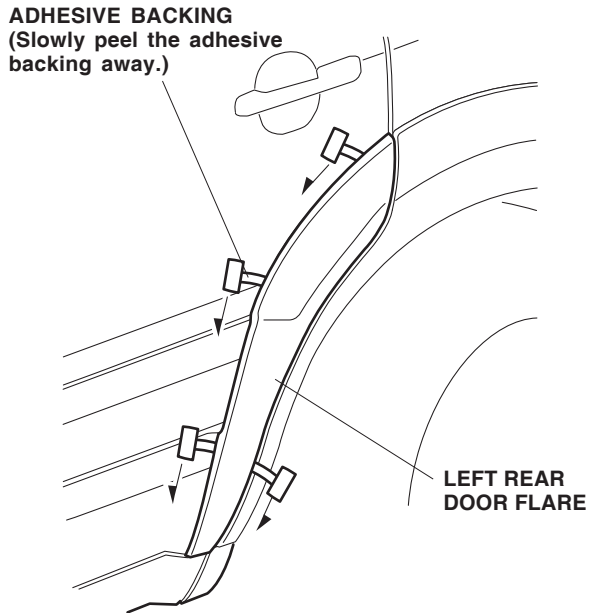

38. Repeat steps 1 through 37 to install the fender flares on the right side of the vehicle.