



INSTALLATION INSTRUCTIONS

Accessory

DOOR VISOR

Application

2008 PILOT

Publications No.

All 37157

Issue Date

JUNE 2007

PARTS LIST

Door visor (Front left)

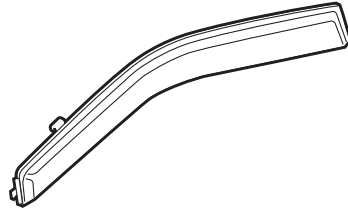

Door visor (Front right)



Door visor (Rear left)



Door visor (Rear right)



4 EPT sealers

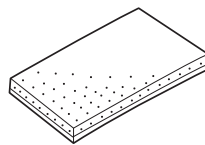

Primer

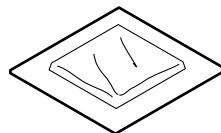

TOOLS AND SUPPLIES REQUIRED

Isopropyl alcohol

Shop towel

Masking tape

INSTALLATION

NOTE:

- These instructions show the left door visors being installed. The same procedure applies to installing of the right door visors.
- Be careful not to damage the paint finish and glass run channels when installing the door visors.
- Handle the door visors with care. They are not designed to absorb shock or impact.
- This door visor kit should only be installed if the ambient air temperature is 60°F (15°C) or above.
- To allow the adhesive to cure, do not wash the vehicle for 24 hours.
- Read the label on the primer before using the primer.

Installing the Front Door Visor

1. Lower the front door glass completely. Remove the door glass run channel from the door sash in the area shown.

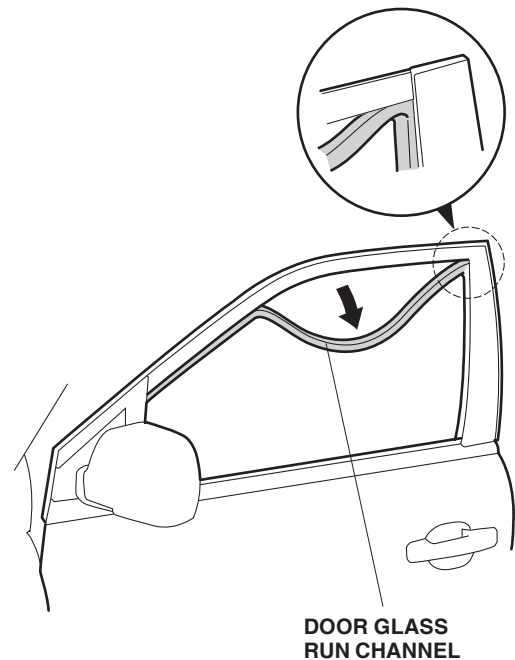

- Using a scale, measure the door sash and apply masking tape to the door sash as shown.

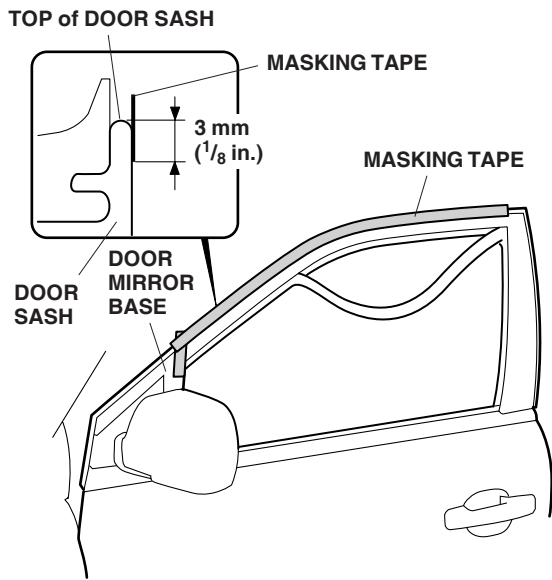

- Using a scale, measure the door and the pillar trim, then apply masking tape to the door and the pillar trim as shown.

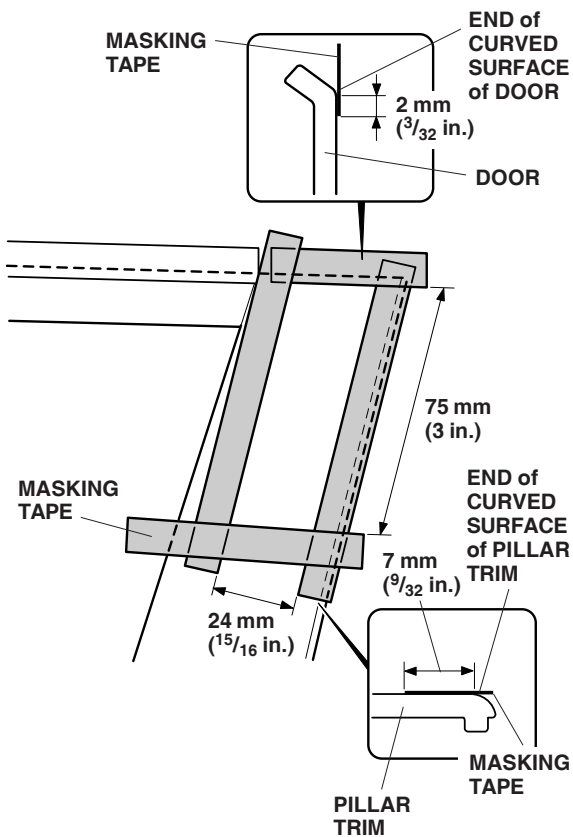

- Using isopropyl alcohol, thoroughly clean the area where the door visor will be attached.

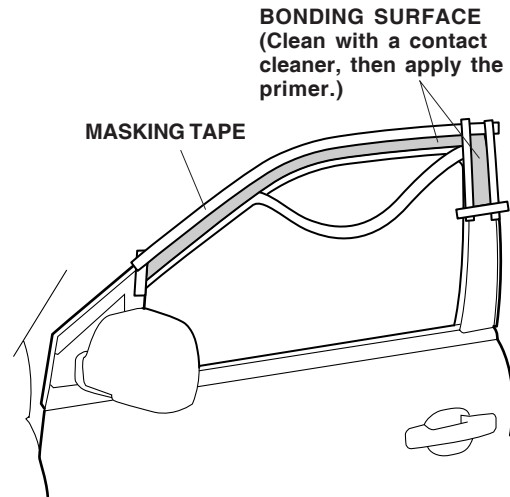

- Apply the primer to the door sash (shaded area).

NOTE: Save the primer for the other doors.

- Wipe up excess primer at once.
 - Allow the primer to dry for at least 3 minutes, then remove the masking tape.
 - Wear gloves when applying the primer.
- Remove the masking tapes.
 - Remove the adhesive backing from the EPT sealer, and attach the EPT sealer to the door sash as shown.

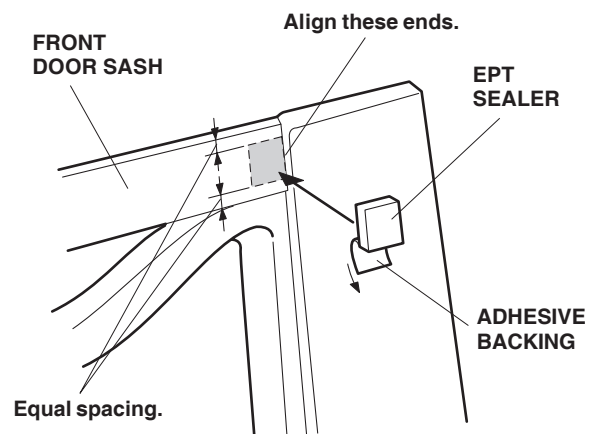

- Attach a strip of masking tape to the end of the adhesive backing at the front of the door visor, and remove 2 to 3 inches from the end. Fold back the end, and tape the end to the back of the door visor.

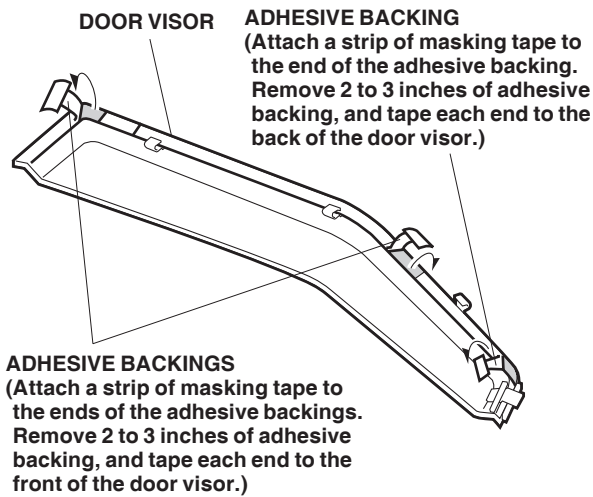

- Attach a strip of the masking tape to the ends of the remaining adhesive backings, and remove 2 to 3 inches from the ends. Fold back the ends and tape the ends to the front of the door visor. Note the direction of the adhesive backings.

- Attach the front bracket of the door visor to the door sash, and push the two rear brackets on the door sash. Insert the front tab under the door mirror base.

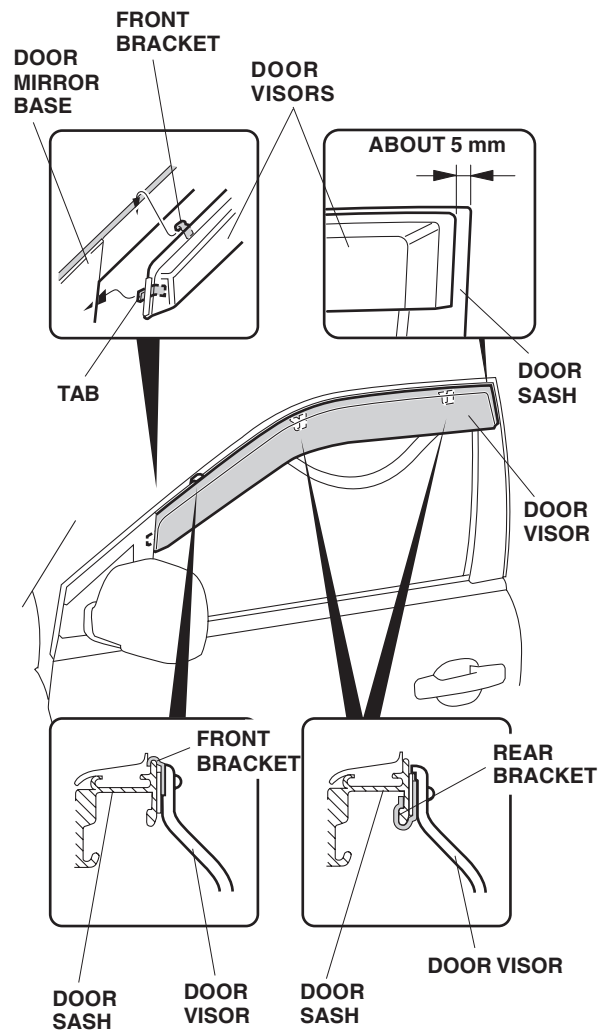

- Adjust the location of the door visor so that the clearance between the door visor and door sash is about 5 mm at the back. There should be no clearance between the front tab and the visor.

- While holding light pressure on the door visor, carefully remove the adhesive backing in the directions shown. Using the palm of your hand, hold the door visor firmly against the door for 30 seconds.

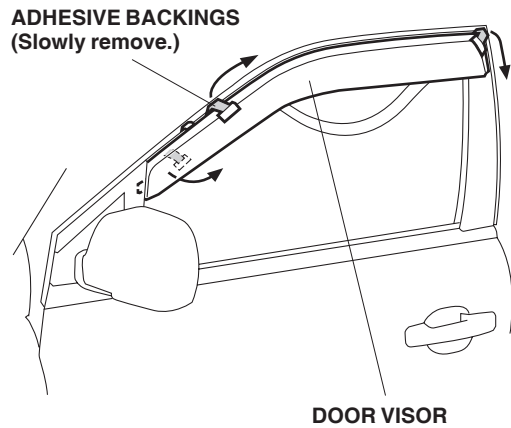

- Reinstall the door glass run channel. **NOTE:** Make sure the run channel is seated properly on the rear brackets.

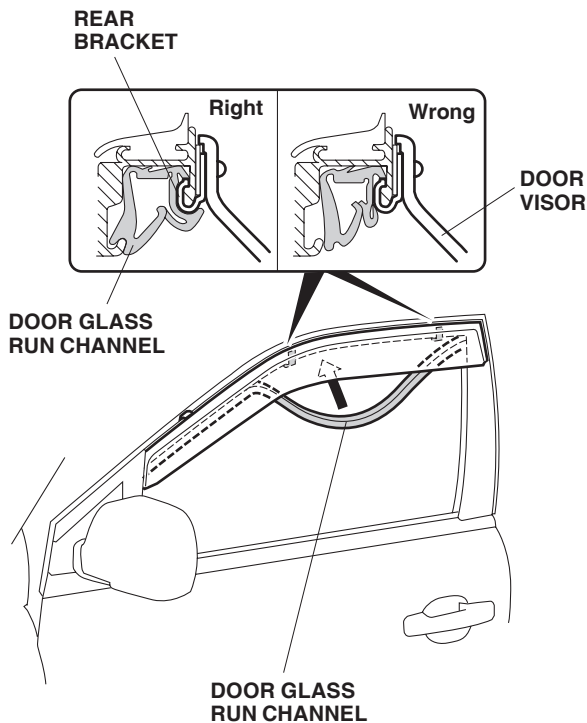

Installing the Rear Door Visor

- Lower the rear door glass completely. Remove the door glass run channel from the door sash in the areas shown.

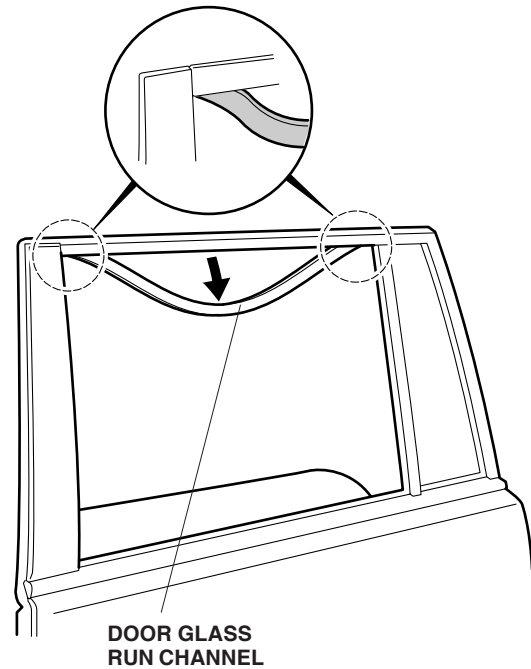

- Using a scale, measure the door sash and apply a masking tape to the door sash as shown.

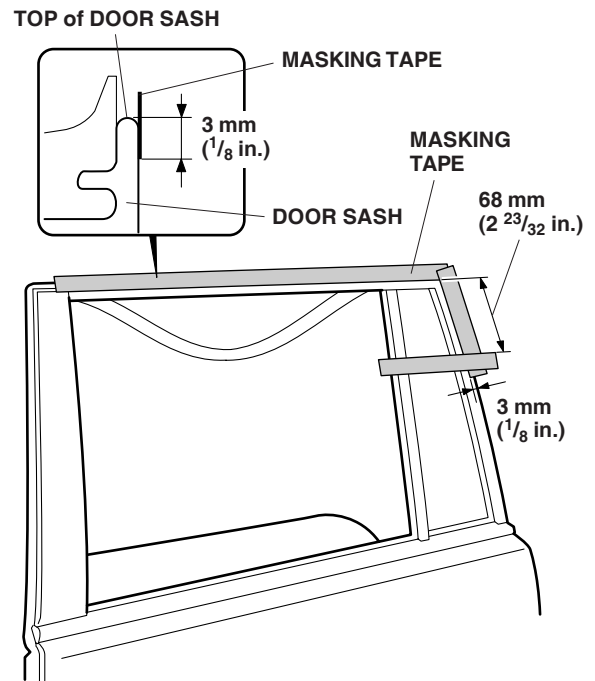

16. Using a scale, measure the door and the pillar trim, then apply masking tape to the door and the pillar trim as shown.

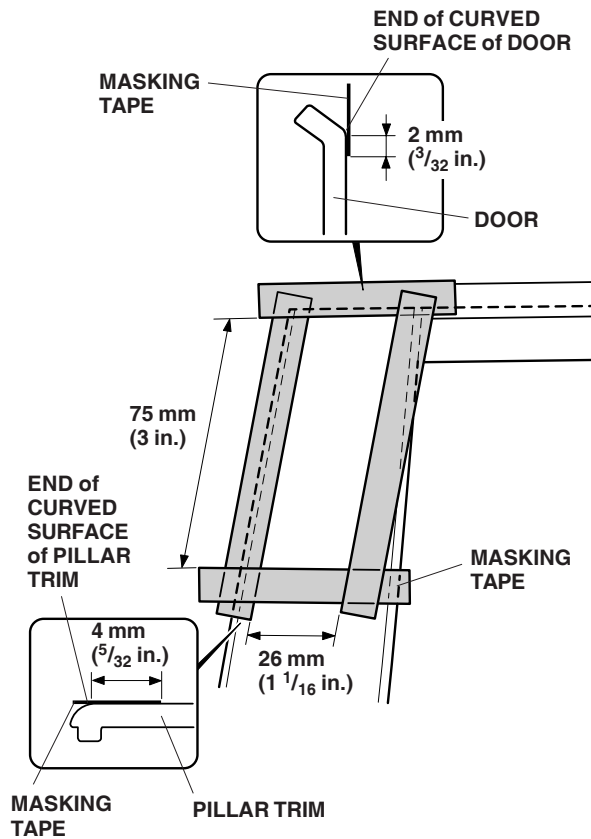

17. Using a contact cleaner, thoroughly clean the area (hatched) where the door visor will be attached.

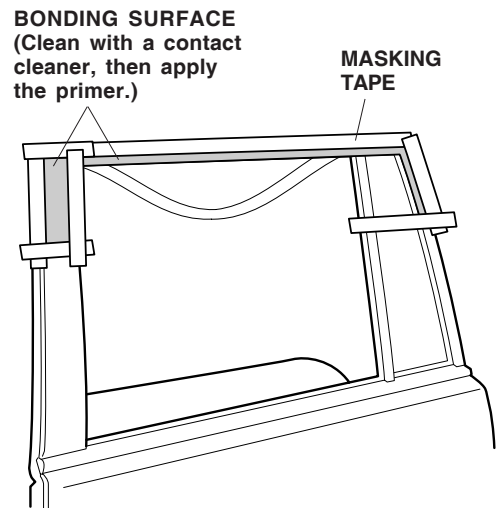

18. Apply the primer to the door sash (shaded area).
- Wipe up excess primer at once.
 - Allow the primer to dry for at least 3 minutes, then remove the masking tape.
 - Wear gloves when applying the primer.
19. Remove the masking tapes.
20. Remove the adhesive backing from the EPT sealer and attach the EPT sealer to the door sash as shown.

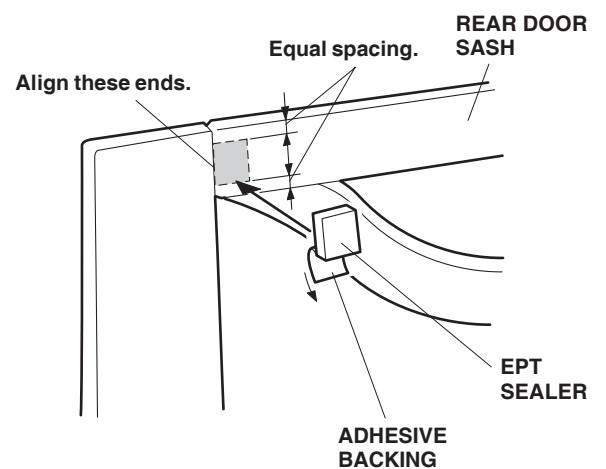

- Attach a strip of the masking tape to the end of the adhesive backing at the rear of the door visor, and remove 2 to 3 inches from the end. Fold back the end and tape the end to the back of the door visor.

ADHESIVE BACKING
 (Attach a strip of masking tape to the end of the adhesive backing. Remove 2 to 3 inches of adhesive backing, and tape each end to the back of the door visor.)

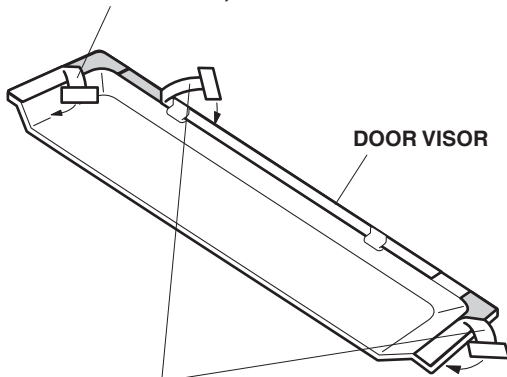

ADHESIVE BACKINGS
 (Attach a strip of masking tape to the ends of the adhesive backings. Remove 2 to 3 inches of adhesive backing, and tape each end to the front of the door visor.)

- Attach a strip of the masking tape to the ends of the remaining adhesive backings, and remove 2 to 3 inches of adhesive backings. Fold back the ends, and tape the ends to the front of the door visor.

- Attach the rear bracket of the door visor to the door sash, and push the two brackets on the door sash.

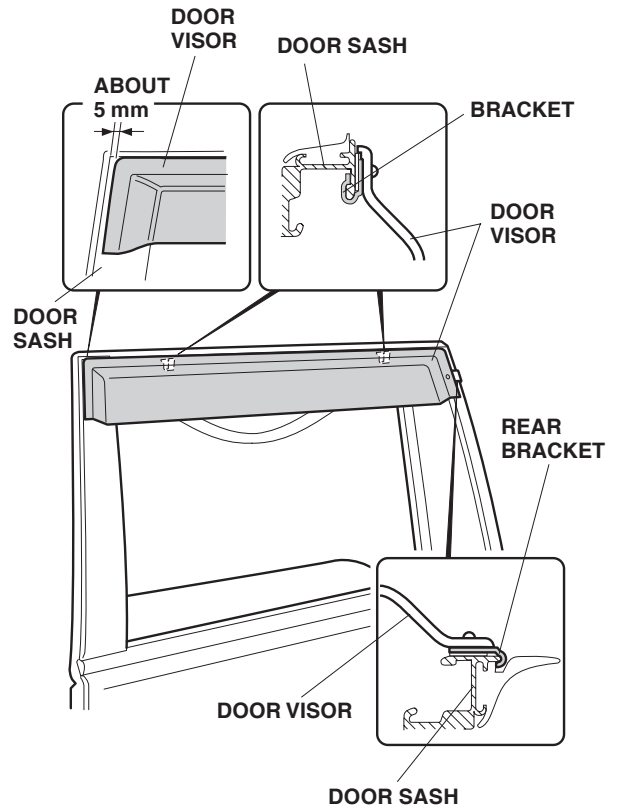

- Adjust the location of the door visor so that the clearance between the door visor and door sash is about 5 mm at the top.

25. While holding light pressure on the door visor, carefully remove the adhesive backing in the directions shown. Using the palm of your hand, hold the door visor firmly against the door for 30 seconds.

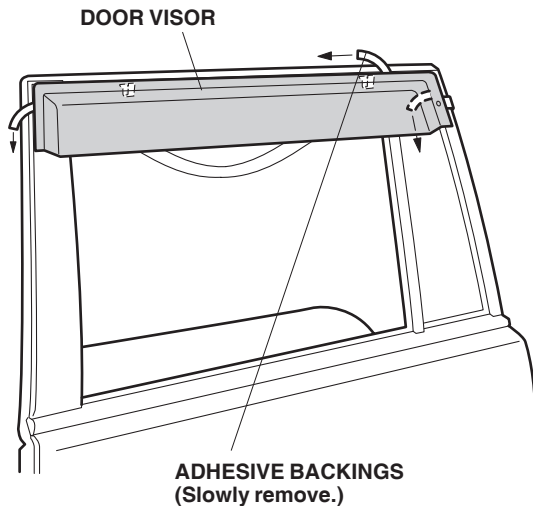

26. Reinstall the door glass run channel. **NOTE:** Make sure the run channel is seated properly on the rear brackets.

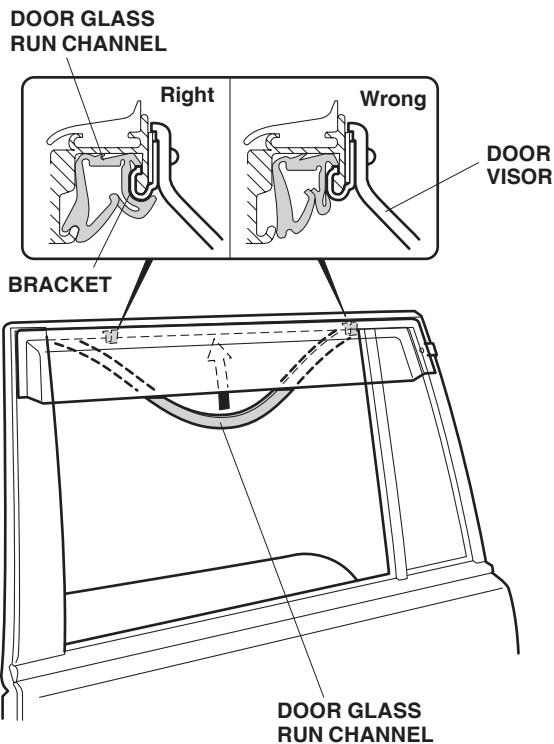

27. Repeat steps 1 through 26 to install the door visors on the right side of the vehicle.
28. Raise and lower all the windows several times to seat the glass run channels.

INSPECTION

Release and set the power window anti-pinch system as described:

To release:

1. Turn the ignition switch OFF.
2. Remove the driver's side power window 20A fuse from the fuse box.
3. Turn the ignition switch ON (II) and continue to hold the switch for one second. Turn the ignition switch OFF and reinstall the 20A fuse after 5 seconds.
4. Again turn the ignition switch ON (II) and make sure that the AUTO feature does not work.

To set:

1. Check that the door and door glass related parts are installed properly.
2. Start the engine.
3. Push down on the DOWN end of the driver's window switch until the window is fully open.
4. Pull back on the UP end of the driver's window switch until the window is fully closed and continue to hold the switch for two seconds.
5. Make sure that the AUTO feature works correctly. If not, repeat step 1 through 4.

USE AND CARE

- To clean the door visor, wipe it with a soft cloth dampened with clean water.
- To remove dust and dirt, clean with a solution of liquid dishwashing soap and water using a soft cloth. Never use organic solvents such as thinner, benzene, alcohol, etc., or cleaners containing compounds.