



INSTALLATION INSTRUCTIONS

Accessory	Application	Publications No.
BUMPER TRIM PIECES P/N 08F23-S9V-101A	2008 PILOT	All 37146
		Issue Date
		JUNE 2007

PARTS LIST

Left front trim piece



Right front trim piece



Left rear trim piece



Right rear trim piece



4 Brackets "A"

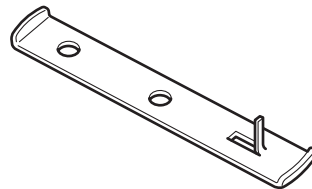

6 Brackets "B"

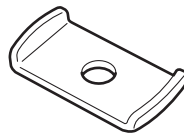

10 Flange nuts



Template

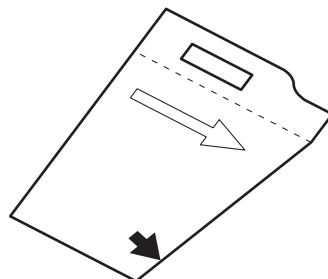

TOOLS AND SUPPLIES REQUIRED

- Phillips screwdriver
- Flat-tip screwdriver
- Ratchet
- 10 mm Socket
- Drill
- 3 mm and 7 mm Drill bit
- 1-1/8" (28 mm) Hole saw
- Center punch
- File
- Torque wrench
- Masking tape
- Isopropyl alcohol
- Shop towel

INSTALLATION

Customer Information: The information in this installation instruction is intended for use only by skilled technicians who have the proper tools, equipment, and training to correctly and safely add equipment to your vehicle. These procedures should not be attempted by "do-it-yourselfers."

NOTE:

- An optional full nose mask cannot be used after the chrome bumper trim pieces are installed.
- Be extremely careful not to damage the body paint finish.
- To prevent damage, rest the front bumper on a blanket during the installation.
- This bumper trim pieces should only be installed if the ambient air temperature is below 65 °F (15 °C) or above.
- To allow the adhesive to "cure," do not wash the vehicle for 24 hours.

Installing the Front Bumper Trim Pieces

1. Open the hood. Remove the front bulkhead cover (13 clips).

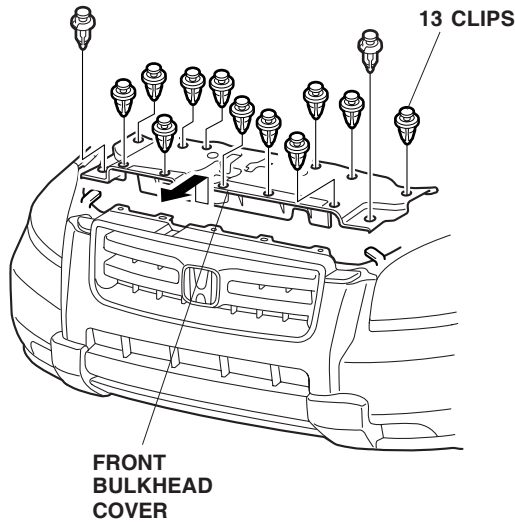

2. Remove the front bumper (two short clips, two self-tapping screws, four bolts, and two long clips). To prevent damage, rest the bumper on a blanket.

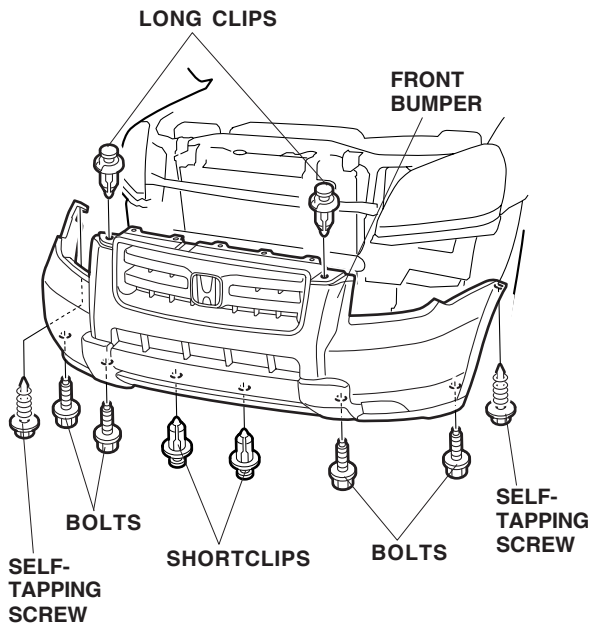

3. Bend the template under, and align the line. Align the hole of the template with the hole of the front bumper, and secure the template with the pieces of masking tape. Note the direction of the template.

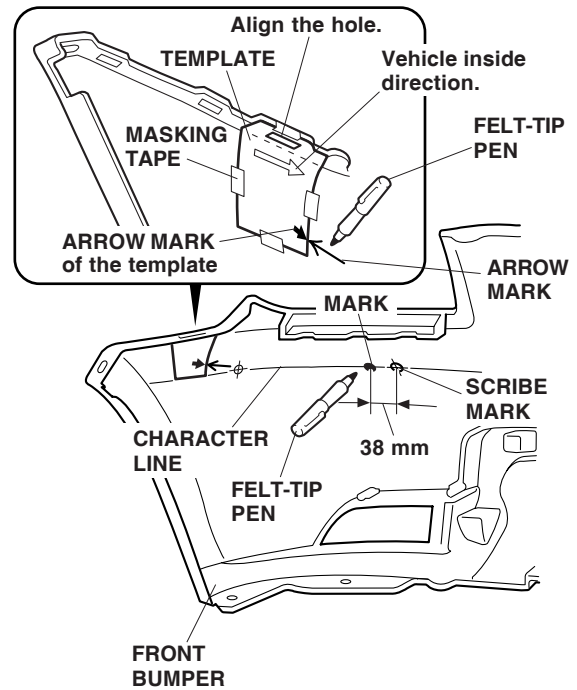

4. Using a felt-tip pen, add the arrow mark to the front bumper against the arrow mark on the template. Drill point is top of arrow.
5. Using a tape measure and felt-tip pen, measure and mark the front bumper as shown.

- On the inside of the front bumper, locate the two marks on the left side. Center-punch each of the two marks you made.

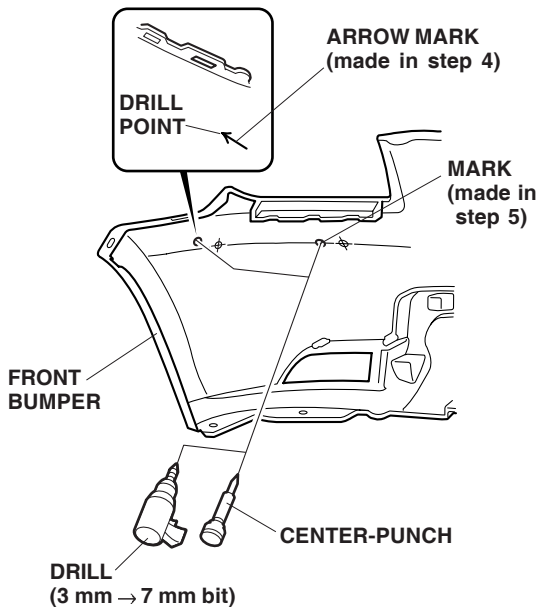

- While wearing eye protection, drill a 7 mm hole through each of the center-punched marks. First drill with a 3 mm bit, and finish with a 7 mm bit. Remove any burrs from the edges of the holes.
- On the inside of the front bumper, locate the two marks on the left side. Center-punch each of the two scribe marks.

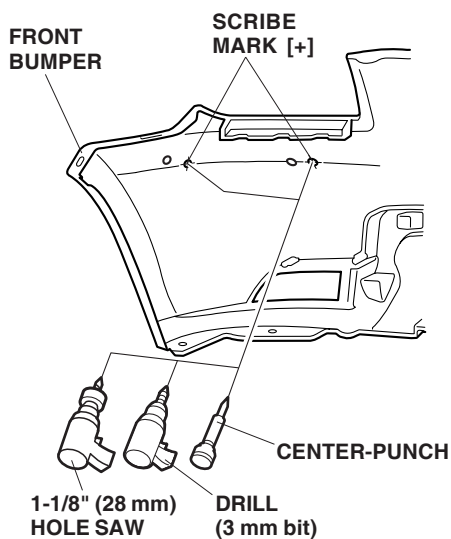

- While wearing eye protection, drill an 1-1/8" (28 mm) hole through each of the center-punched marks. First drill with a 3 mm bit, and finish with an 1-1/8" (28 mm) hole saw. Remove any burrs from the edges of the holes.

- Place the left front trim piece on the front bumper, and adjust it until it fits snug. Using strips of masking tape, mark the location of the trim piece.

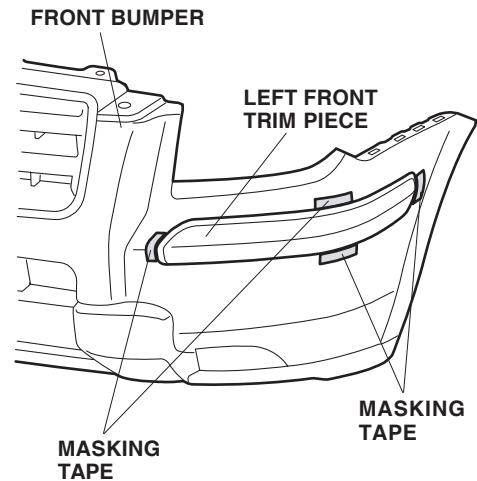

- Attach a strip of masking tape to the ends of the four adhesive backings shown, and peel back 2 to 3 inches from the ends. Fold the ends up and tape them to the front of the trim piece. Remove the remaining two adhesive backings.

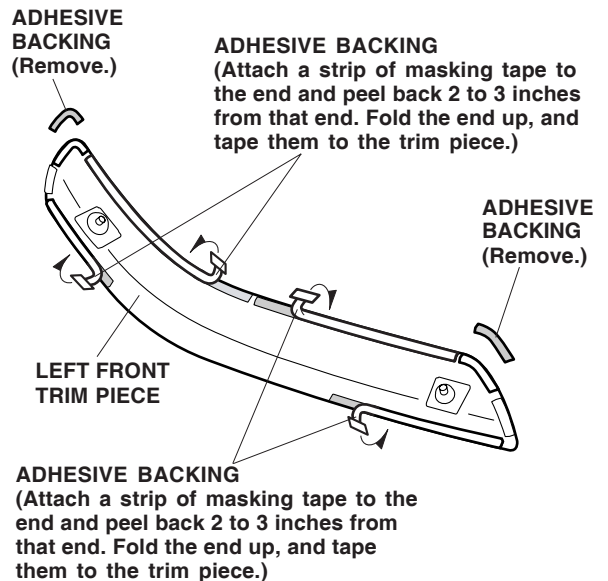

- Using isopropyl alcohol on a shop towel, clean the area where the trim piece will attach.

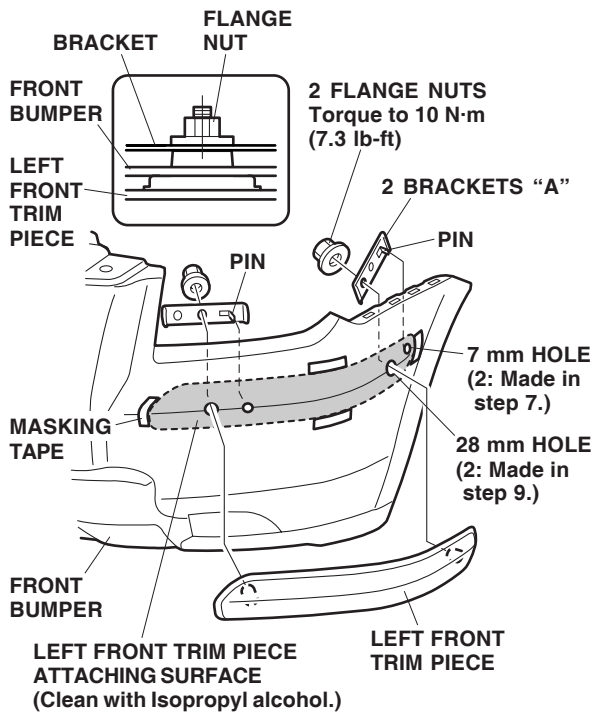

- Position the left front trim piece on the front bumper and align the edges with the masking tape. Install one bracket "A" and one flange nut on each stud from the trim piece. Note the direction of the brackets.
- While holding light pressure on the left front trim piece, slowly and carefully remove the adhesive backings.

- Torque the flange nuts to 10 N·m (7.3 lb-ft).

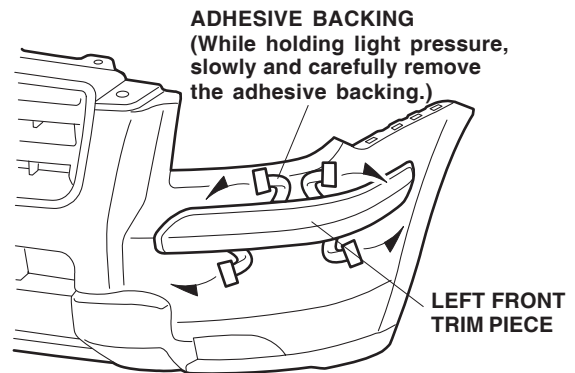

- Repeat steps 3 through 15 to install the trim piece on the right side of the bumper.
- Reinstall the front bumper, and the front bulkhead cover.

Installing the Rear Bumper Trim Pieces

- Remove the two short self-tapping washer-screws, four self-tapping screws, two long self-tapping washer-screws, two washer-screws, four clips and five bolts that secure the rear bumper. Slide the rear bumper out to release the two fender clips. Set the bumper on a blanket.

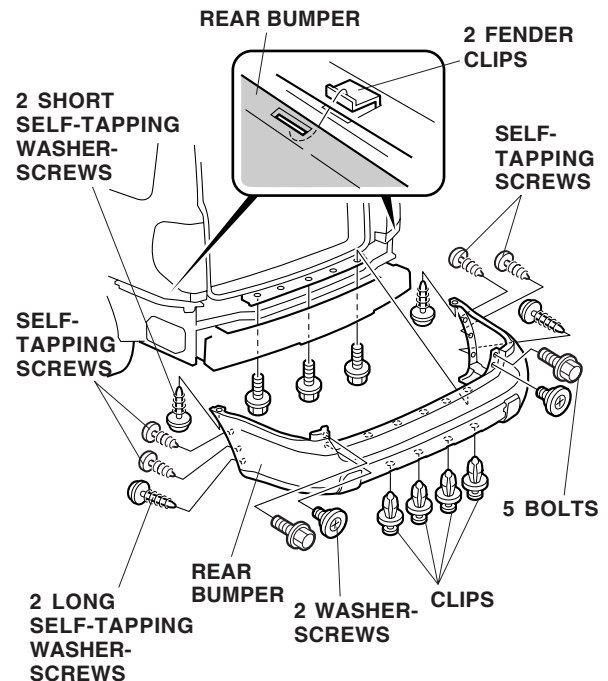

19. On the inside of the rear bumper, locate the three marks on the left side. Center-punch each of the three marks. The correct marks have brackets ([]) next to them.

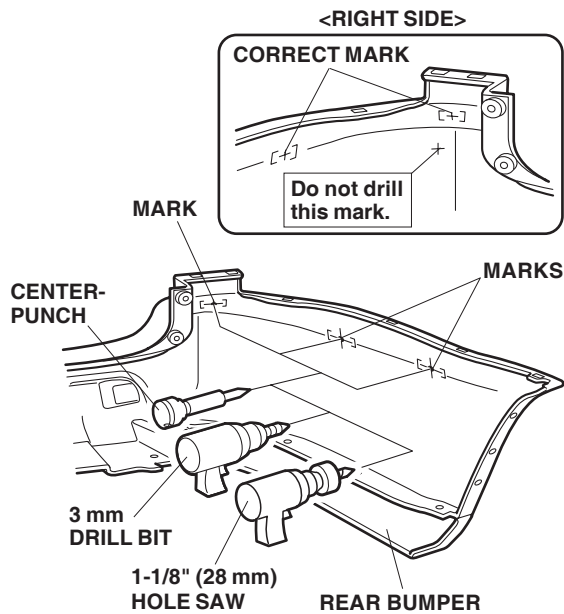

20. While wearing eye protection, drill an 1-1/8" (28 mm) hole through each of the center-punched marks. First drill with a 3 mm bit, and finish with an 1-1/8" (28 mm) hole saw. Remove all burrs from the edges of the holes.
21. Position the left rear trim piece on the rear bumper and adjust it until it fits snug. Using strips of masking tape, mark the location of the trim piece.

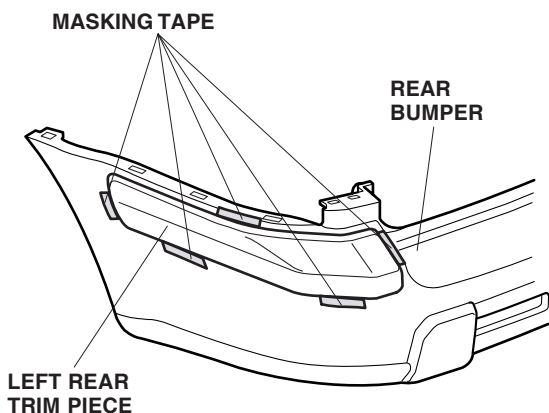

22. Attach a strip of masking tape to the ends of the adhesive backings shown and peel back 2 to 3 inches from the ends. Fold the ends up and tape them to the front of the trim piece. Remove the remaining adhesive backing.

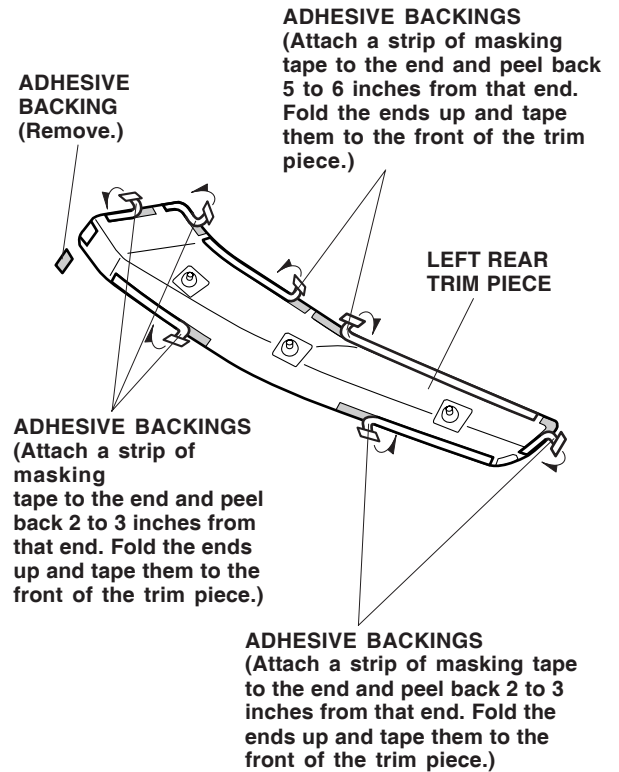

- Using isopropyl alcohol on a shop towel, clean the area where the trim piece will attach.

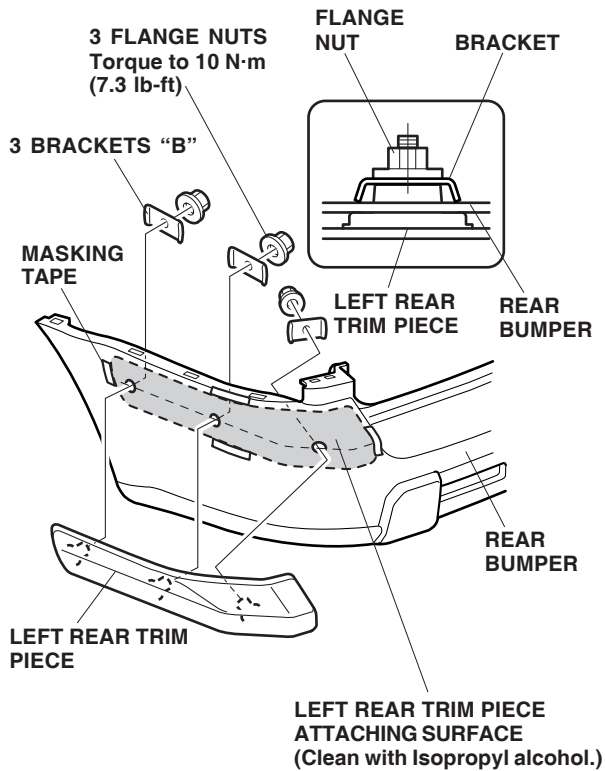

- Position the left rear trim piece on the rear bumper, and align it with the masking tape. Install one bracket "B" and one flange nut over each stud on the trim piece. Note the direction of the brackets.

- While holding light pressure on the trim piece, slowly and carefully remove the adhesive backings.

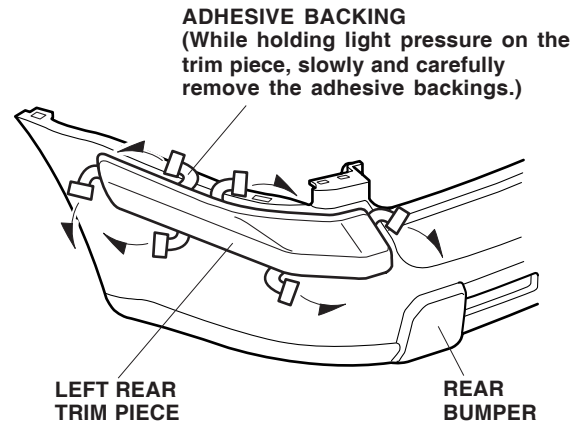

- Torque the flange nuts to 10 N·m (7.3 lb-ft).
- Repeat steps 19 through 26 to install the trim piece on the right side of the bumper.
- Reinstall the rear bumper.
- Remove all of the masking tape.