



INSTALLATION INSTRUCTIONS

Accessory	Application	Publications No.
STEERING WHEEL COVER	2008 FIT	All 37491
		Issue Date
		JUL 2007

PARTS LIST

Steering Wheel Cover

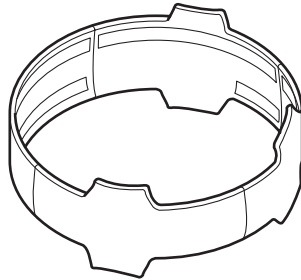

Needle

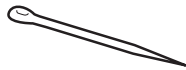

Lacing String

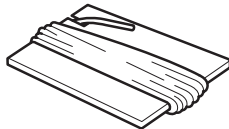

SUPPLIES REQUIRED

Isopropyl alcohol

Shop towel

INSTALLATION

NOTE:

- Before installing the wheel cover, thoroughly clean the steering wheel with isopropyl alcohol.
 - Lace up the steering wheel cover carefully so you do not cut it with the lacing.
1. Peel back 1- 1/2 to 2 inches of the adhesive backings as shown.

7 ADHESIVE BACKINGS

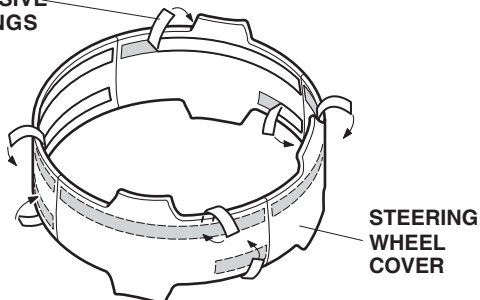

2. Place the steering wheel cover over the steering wheel with the nonholed sections of the wheel cover aligned with the spokes of the steering wheel as shown.

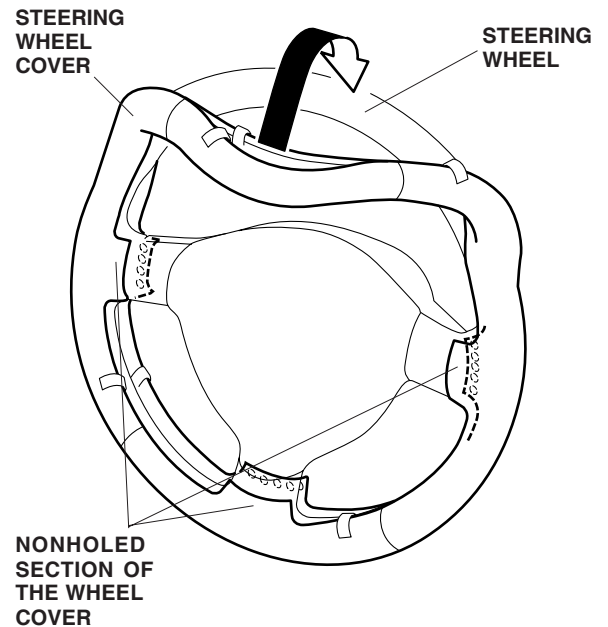

3. Thread the lacing string through the needle as shown.

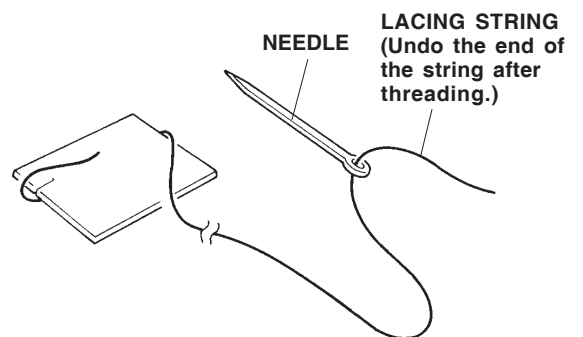

4. Remove the adhesive backings one section at a time before lacing.

5. Start the lacing at the star-marked position and lace clockwise.

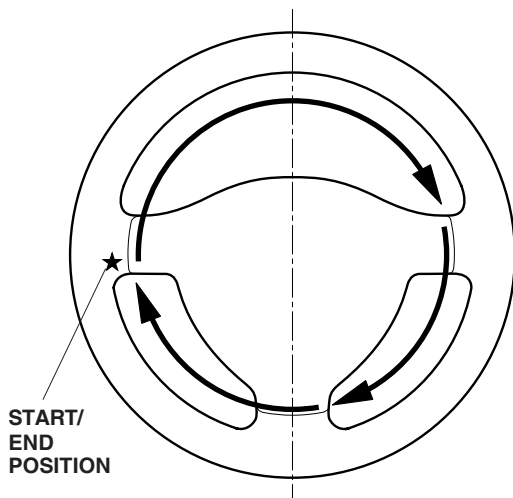

6. Put the needle through the first lacing hole from the rear. Pull all but 100 mm (3.94 in.) of the string out through the hole.
7. Lace up to the corner lacing hole in the spoke. Make a double stitch at this corner lacing hole and at the one on the inside hole.

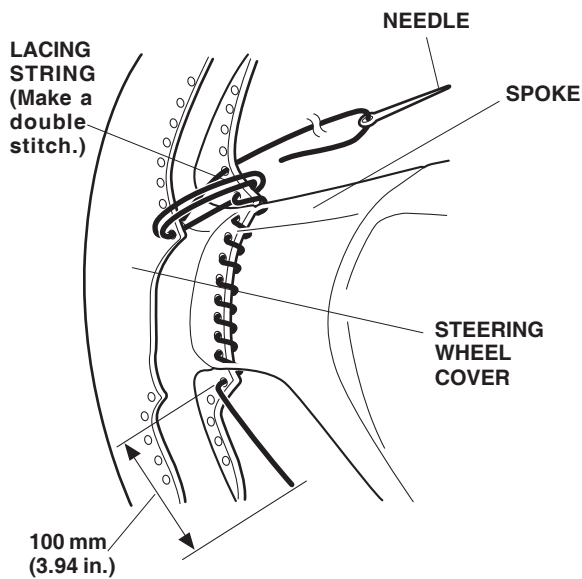

8. Pull the string from the double-stitched lacing hole on the back to the next lacing hole on the cover. Pull the string to butt the edges of the wheel cover together.

Lace up the steering wheel cover until the mating edges of the steering wheel cover come in contact with each other. Do not pull the lace too tight as it can cut the steering wheel cover or break the string.

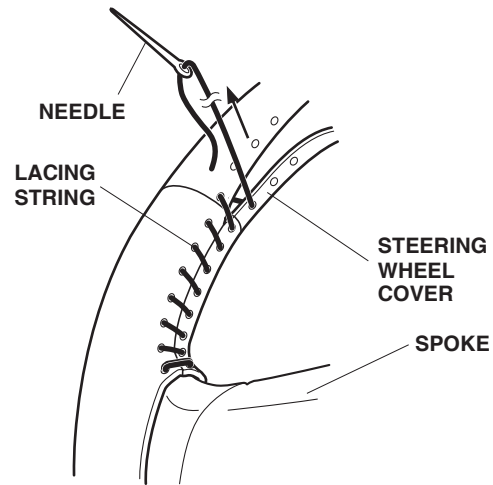

9. Make a double stitch at each of the asterisked points.

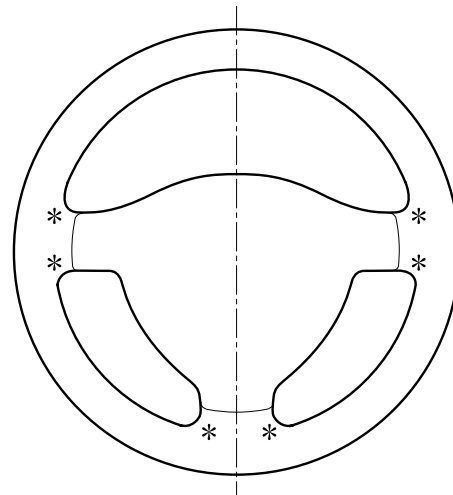

10. Continue lacing so that the two edges of the cover are aligned along the inner radius of the steering wheel.

11. Tighten the lacing at every stitch so that the edges of the steering wheel cover touch each other. Do not skip any lacing hole. Make sure that the ends of each seam are aligned neatly.

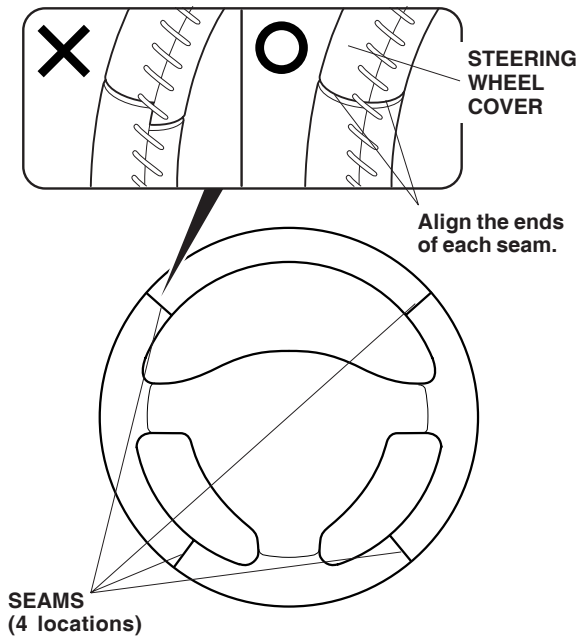

12. At each spoke, double-stitch the lacing string through the holes as shown.

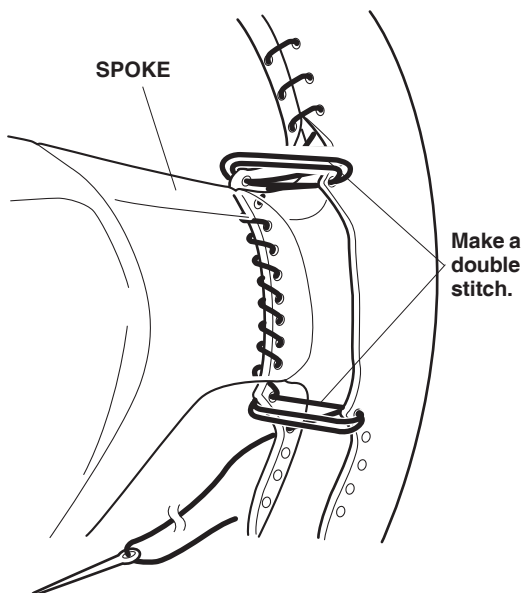

13. When lacing has been completed, pull the string out of the cover opening. (Confirm that both ends of the string come out at the seam joint of the cover.) Tie a tight double knot, and cut off the excess string at the knot. Hide the knot by pushing it into the inside of the steering wheel cover.

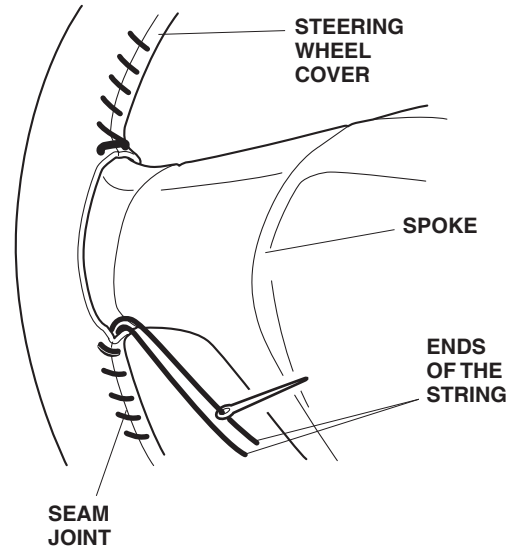

14. After installing the steering wheel cover, use the palm of your hands to hold pressure against each section for 30 seconds to secure the adhesive.