



INSTALLATION INSTRUCTIONS

Accessory

ENGINE BLOCK HEATER
P/N 08T44-SVB-100

Application

2008 CIVIC SI

Publications No.

All 37800

Issue Date

AUG 2007

PARTS LIST

Engine block heater

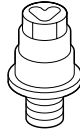

Aluminium washer



Heater harness



Protective cap

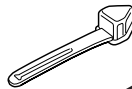

15 Black Wire ties

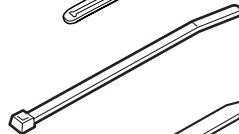

3 Wire ties with clips
(2 Not used)

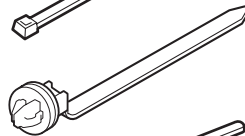

5 White Wire ties



TOOLS AND SUPPLIES REQUIRED

Ratchet

10 mm, 19 mm and 24 mm Sockets

Torque wrench

Diagonal cutters

Heavy gloves

Drain pan

Tape measure

White marker

Coolant (Honda Antifreeze/Coolant only, in a 50/50 mixture with water)

NOTE:

- Always use Honda Antifreeze/Coolant. Using a non-Honda coolant can result in corrosion, causing the cooling system to malfunction or fail.
- To avoid burning out the element, do not operate the engine block heater before it is installed in the vehicle and before you add coolant.

INSTALLATION

Customer Information: The information in this installation instruction is intended for use only by skilled technicians who have the proper tools, equipment, and training to correctly and safely add equipment to your vehicle. These procedures should not be attempted by "do-it-yourselfers."

1. Turn the ignition to ON (II), turn on the wiper switch, move the wiper arms to the vertical position, then turn the ignition off.

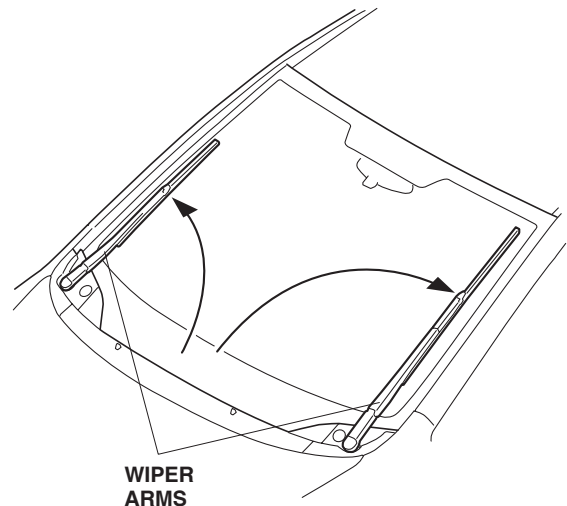

WIPER ARMS

2. Disconnect the negative (-) cable from the battery, then open the positive cable cover and disconnect the positive (+) battery cable from the battery. Loosen the two battery holder nuts and remove the battery holder, then remove the battery upper cover, battery, and battery under cover.

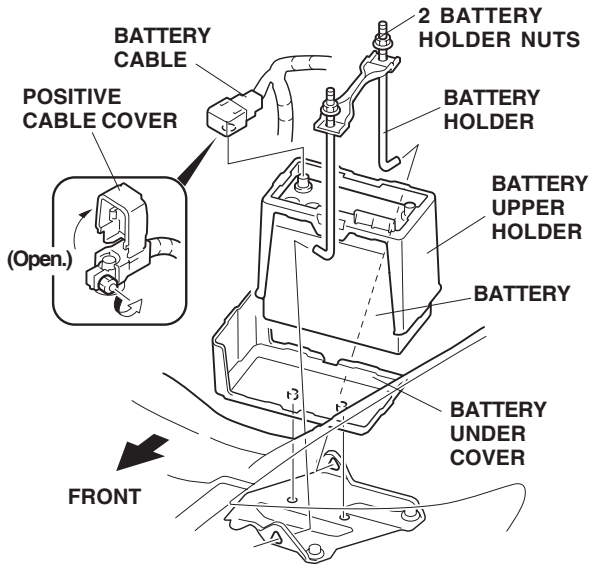

3. Allow the engine and all cooling system components to cool down.
4. Place a clean drain pan under the radiator drain plug, then remove the drain plug from the bottom of the radiator to drain the coolant. Remove the radiator cap to increase the flow.

NOTE: Radiator coolant will damage paint. Quickly rinse any spilled coolant from painted surfaces.

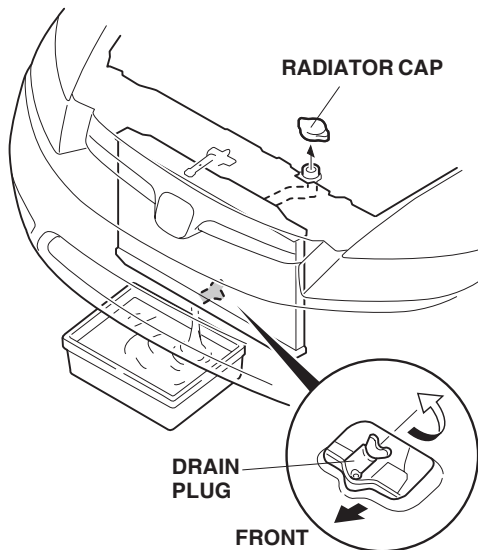

5. Remove the cowl cover:
 - Remove the hood rear seal.
 - Disconnect the washer hose and remove the three clips.
 - Remove the cowl cover (six clips and six hooks).

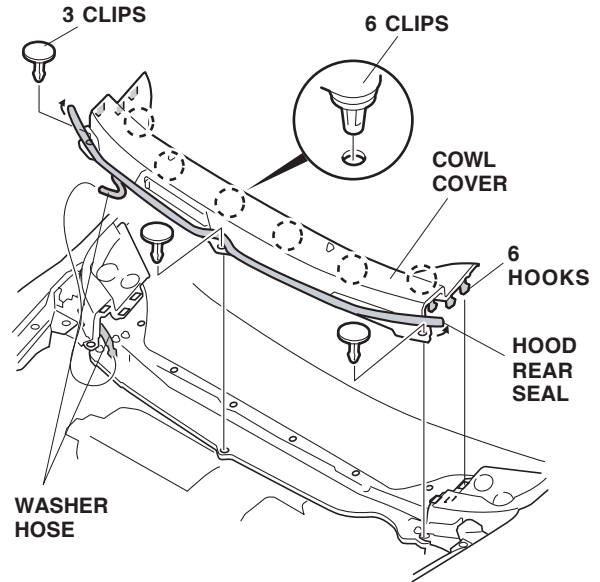

6. Remove the cowl (nine bolts).

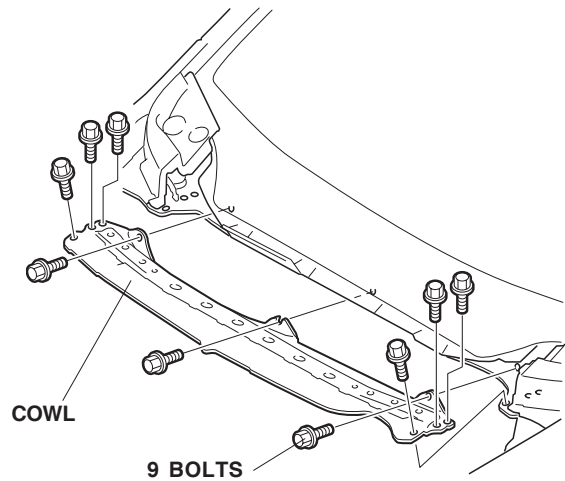

- Disconnect the vehicle 5-pin connector from the air cleaner cover. Remove the clip from the air cleaner upper cover and release the vehicle harness from the holders on the air flow tube.

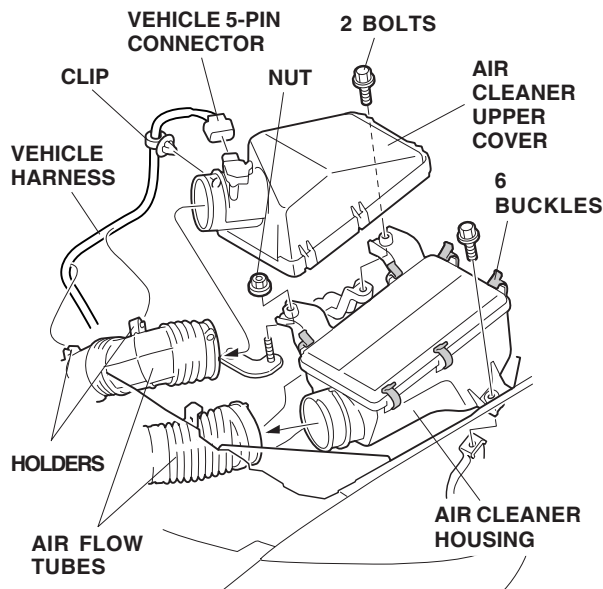

- Disconnect the air flow tube from the air cleaner upper cover. Remove the air cleaner upper cover (six buckles).
- Disconnect the air flow tube from the air cleaner housing. Remove the air cleaner housing (one nut and two bolts).

- Using a tape measure, measure the heater harness and mark it at the A and B points shown. Install one wire tie with clip on the heater harness in the position shown.

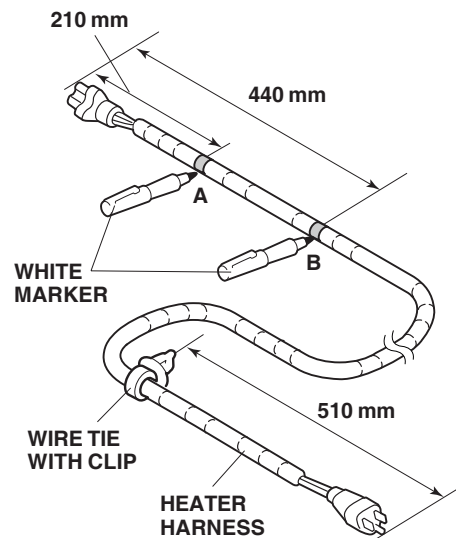

- Locate and remove the engine block drain bolt and washer. Coolant remaining in the engine jackets flows out of the bolt hole when the bolt is removed. (Retain the bolt and washer in case the block heater is removed.)

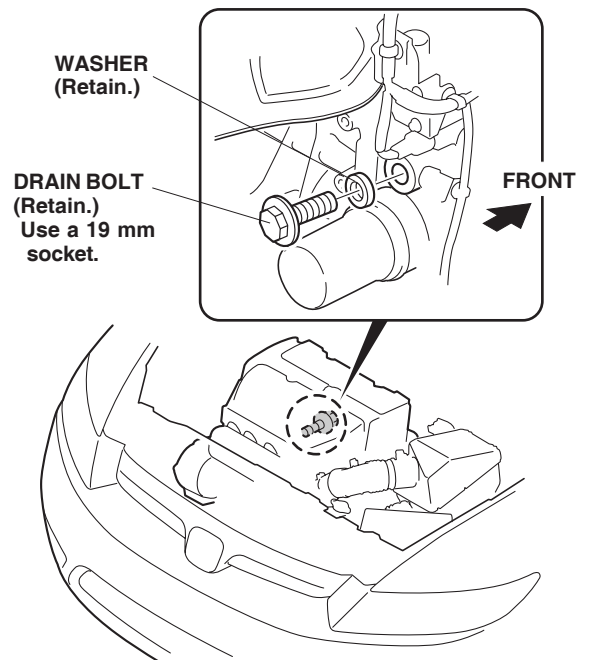

- Install the new aluminium washer and the engine block heater into the bolt hole using a 24 mm socket and a torque wrench. Torque the engine block heater to 60 N·m (6 kgf·m, 44 lbf·ft).

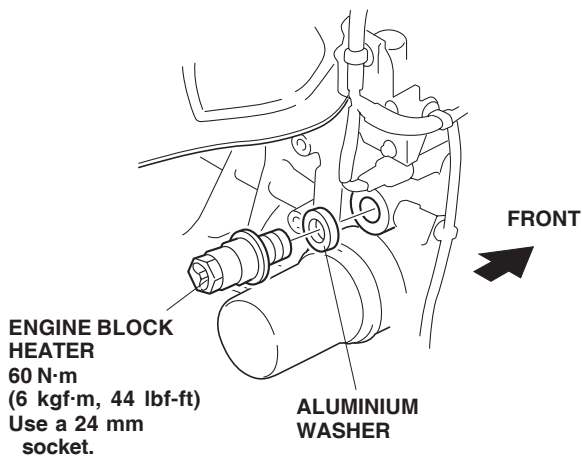

- Route the heater harness down to the engine block heater. Connect the heater harness connector to the engine block heater.

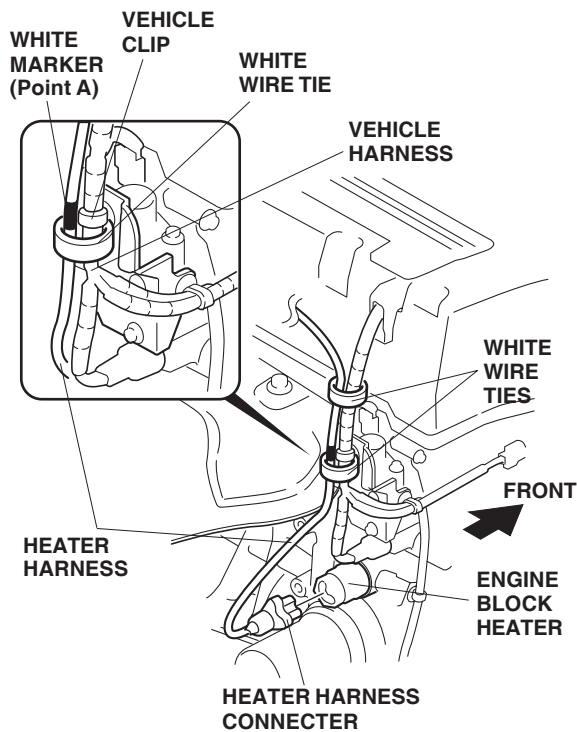

- Secure the heater harness to the vehicle harness with one white wire tie at the marked point A. Secure the heater harness to the vehicle harness using a white wire tie above the marked point A.

- Secure the heater harness to the vehicle harness with one black wire tie at the marked point B.

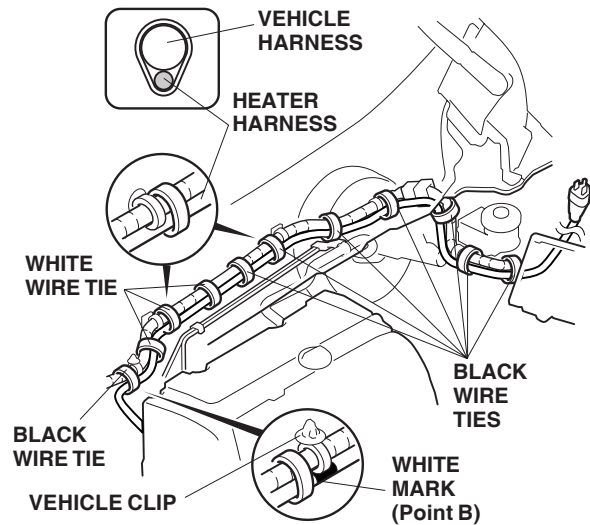

- Route the heater harness along the vehicle harness and secure it to the vehicle harness using three white wire ties and seven black wire ties.

- Route the heater harness under the vehicle harness.
- Make sure the heater harness does not interfere with the brake line when secured.

- Route the heater harness down below the fan shroud.

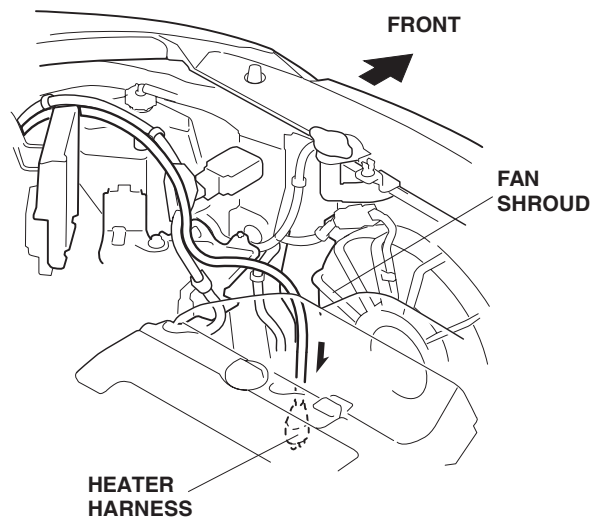

- Secure the wire tie with clip, (installed on the heater harness in step 10) to the vehicle frame, and route the heater harness to the front bumper opening.

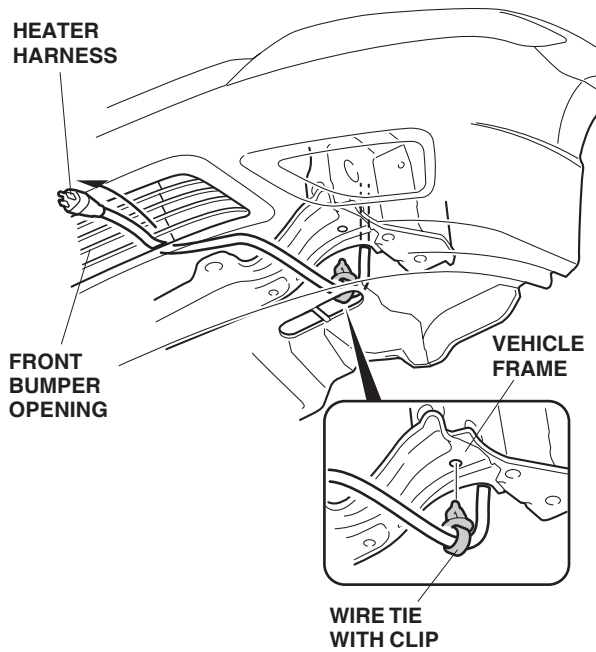

- Secure the heater harness to the vehicle harness using five black wire ties.

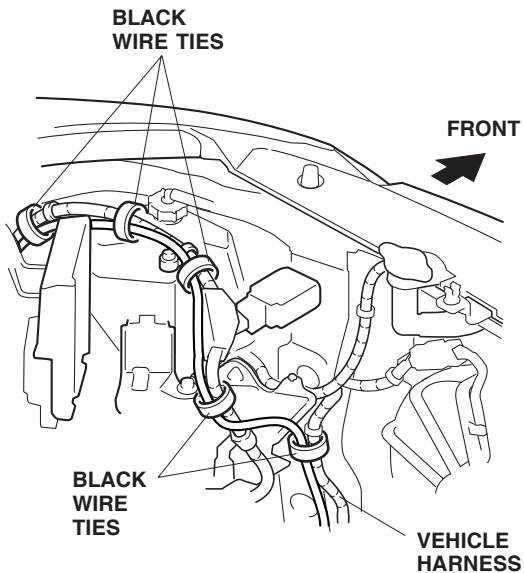

- Route the heater harness on the inside of the bumper opening and secure it to the grille with two black wire ties.

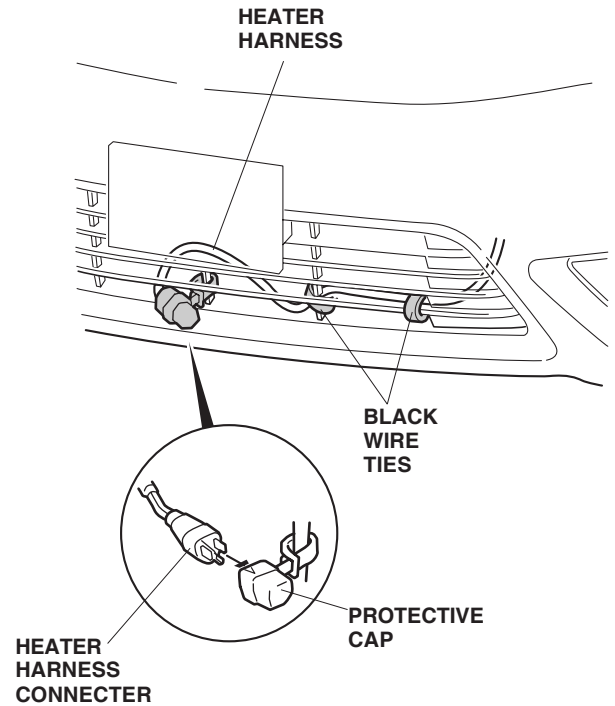

- Attach the protective cap to the grille, and plug the heater harness connector into the protective cap.
- Reinstall all removed parts.

23. Reinstall the radiator drain plug.
24. Fill the system with the recommended coolant. Follow the instructions described in the service manual to fill and bleed the cooling system.
25. Check the coolant reservoir for correct level and check the cooling system for signs of leakage. Repair as necessary.
26. Check that the heater harness is routed properly and all connectors are plugged in.
27. Put the drain bolt (removed in step 11) in the glove box.
28. Reconnect the negative cable to the battery.
29. Enter the customer's radio anti-theft code, and reset the radio station presets.
30. Reset the clock.

NOTE: Whenever the battery is disconnected, the driver's window AUTO function is disabled.

31. Start the engine. Push down on the driver's window switch until the window is fully open.
32. Pull up on the driver's window switch fully to close the window completely, then hold the switch for 2 seconds or more.
33. Test the AUTO window function.