



INSTALLATION INSTRUCTIONS

Accessory
SPORTS SUSPENSION
P/N 08W60-TE1-100

Application
2008 ACCORD
2-DOOR

Publications No.
All 38807
Issue Date
MAR 2008

PARTS LIST

Left front damper assembly

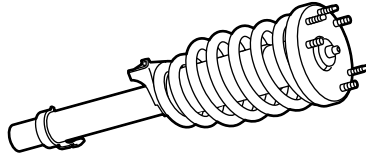

Right front damper assembly

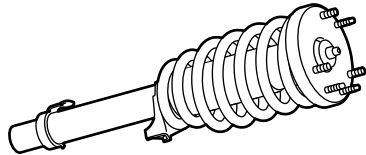

Left rear damper assembly

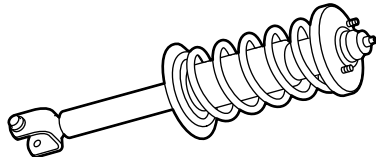

Right rear damper assembly

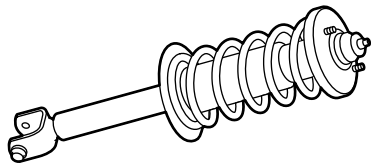

2 Flange bolts, 12 x 80 mm

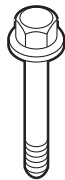

10 Flange nuts



2 Self-locking nuts A, 12 mm



2 Self-locking nuts B, 12 mm



2 Self-locking nuts, 10 mm



Important information

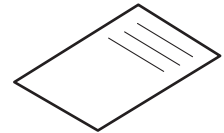

TOOLS AND SUPPLIES REQUIRED

14 mm and 17 mm Combination wrenches

14 mm and 17 mm Socket

Ratchet

Torque wrench

Floor Jack

INSTALLATION

Customer Information: The information in this installation instruction is intended for use only by skilled technicians who have the proper tools, equipment, and training to correctly and safely add equipment to your vehicle. These procedures should not be attempted by "do-it-yourselfers."

NOTE:

- Install the accessory with care to avoid damaging the vehicle.
- Install the parts using the specified bolts and screws. Use of similar bolts/ screws that are not specified ones can cause trouble to the parts and/ or the vehicle.
- Place the vehicle on a firm, level surface.
- Inflate the tires to the specified air pressure.
- Install the right and left dampers in the proper positions.
- These dampers are designed to be used exclusively with this model and should not be used with other models.
- The instructions are for the left side. The same procedure applies to the right side.

Removing the Front Damper

1. With the vehicle on a rack, remove all four wheels.
2. Remove the wheel sensor harness bracket bolt.

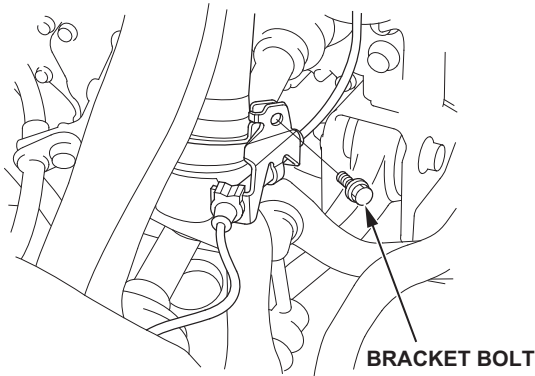

3. Remove the damper pinch bolt and the damper fork mounting bolt while holding the mounting bolt, then remove the damper fork from the damper and the lower arm.

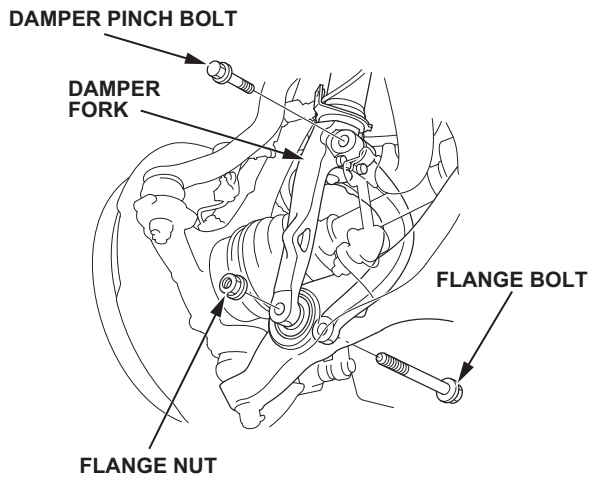

4. Remove the front strut brace mounting nuts (if equipped).

5. Remove the damper mounting nuts from the top of the damper. Do not drop the damper.

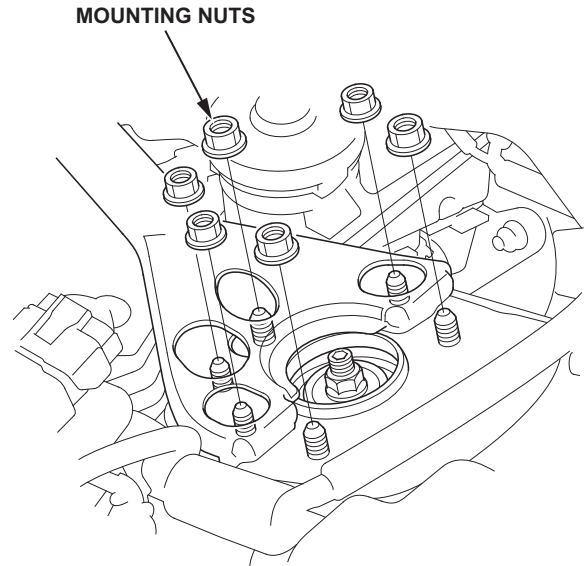

6. Remove the damper.

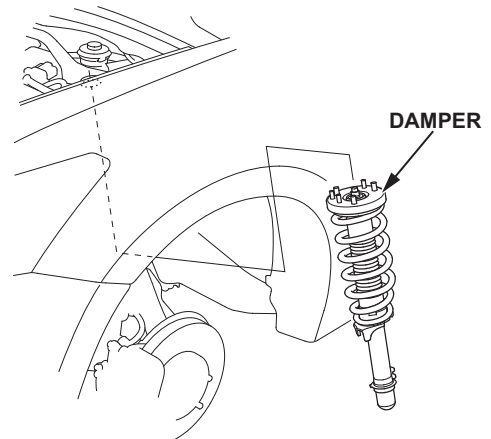

Installing the Front Damper

7. Install the new front damper assembly onto the frame with the aligning tab facing inside.

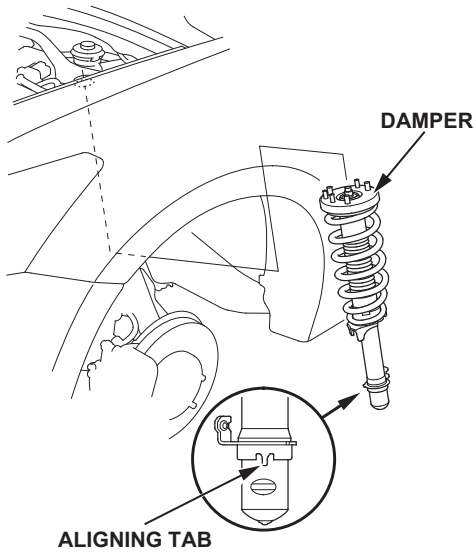

8. Loosely install the new damper mounting nuts to the top of the damper.
9. Loosely install the front strut brace mounting nuts (if equipped).

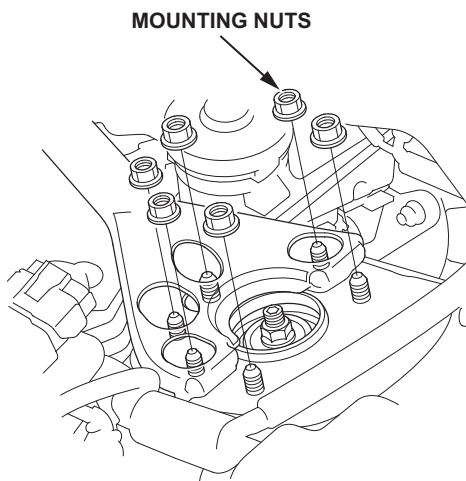

10. Install the damper fork over the driveshaft and onto the lower arm. Install the aligning tab on the damper unit into the slot of the damper fork.
11. Loosely install the damper pinch bolt into the damper fork.
12. Connect the damper fork and lower arm with the new damper fork mounting bolt, then tighten the new mounting nut.

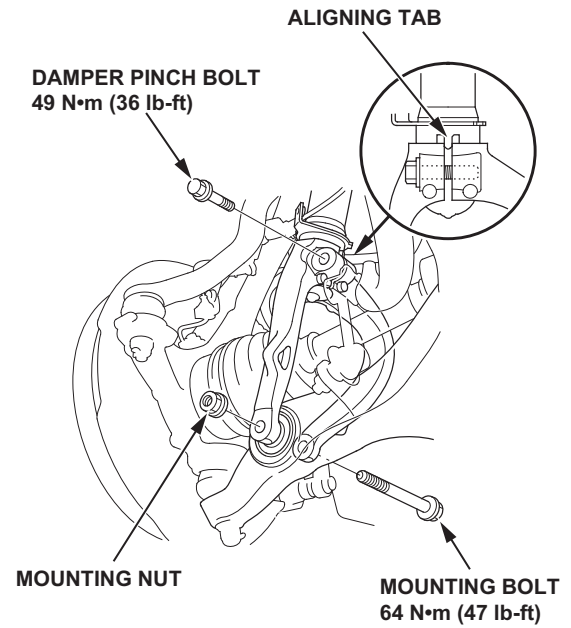

13. With the suspension loaded with the weight of the vehicle, torque the damper pinch bolts 49 N•m (36 lb-ft) and torque the damper fork flange nut and bolt 64 N•m (47 lb-ft).
14. Install the wheel speed sensor harness bracket, and torque to 9.8 Nm (7.2 lb-ft).
15. Repeat steps 2 thru 14 to install the right front.

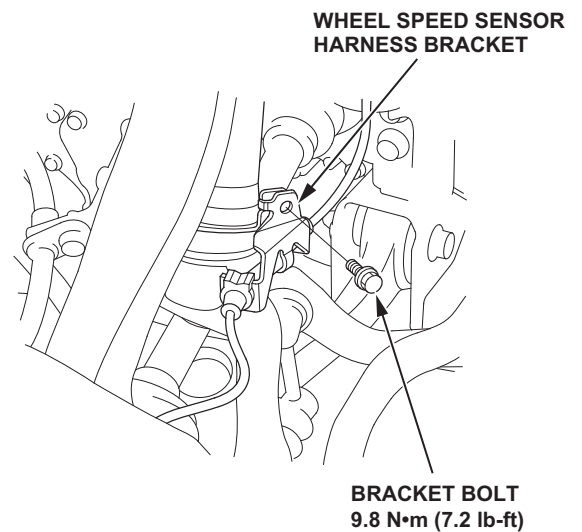

16. Reinstall the front wheels.

Removing the Rear Damper

17. Lower the vehicle near the ground.
18. Fold down the rear seat-back and remove the access lid.
19. Remove the damper mounting nuts from the top of the damper.

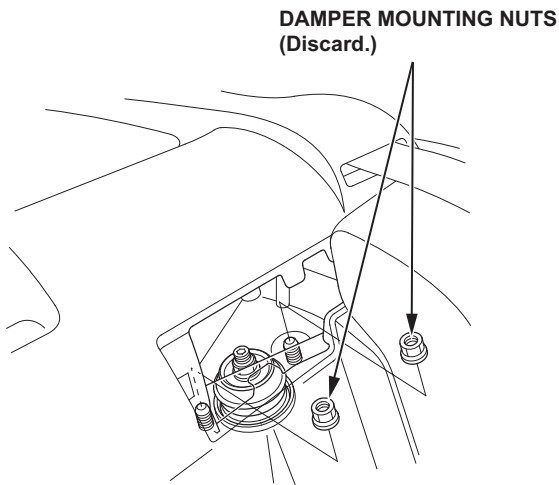
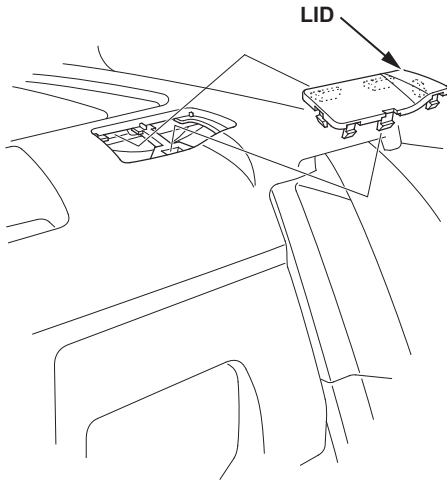

20. Remove the self locking nut while holding the joint pin with a hex wrench, then disconnect the stabilizer link from the knuckle, and remove the brake hose bracket.

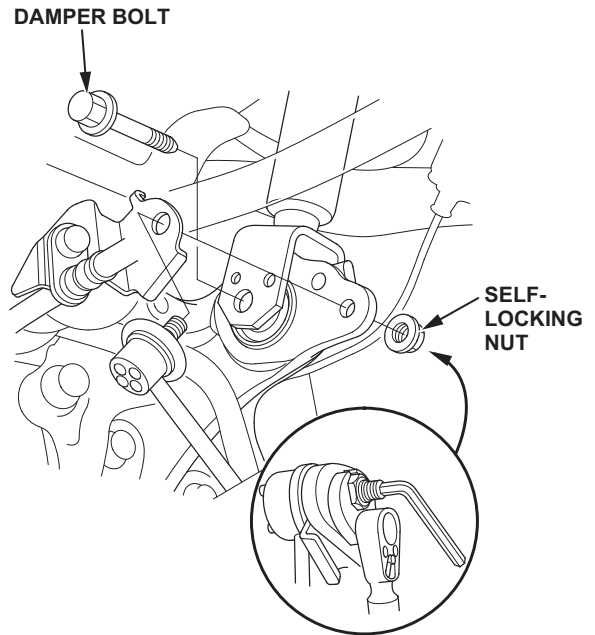

21. Remove the damper mounting bolt.
22. Remove the damper by lowering the rear suspension.

Installing the Rear Damper

23. Lower the rear suspension, and position the damper in the body with the welded nut on the bottom of the damper facing forward.

NOTE: Make sure not to damage the body, and that the damper is installed in the correct position.

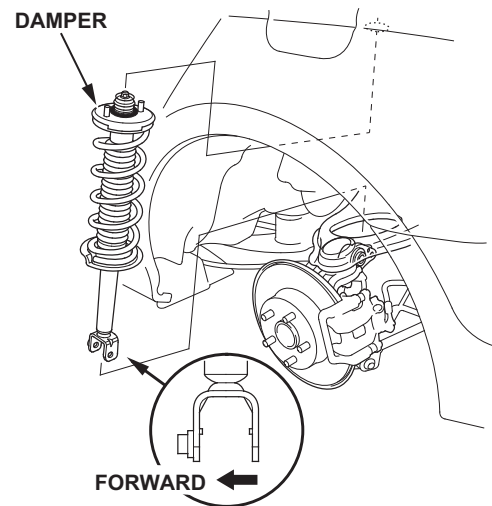

24. Loosely install the new damper mounting nuts to the top of the damper.

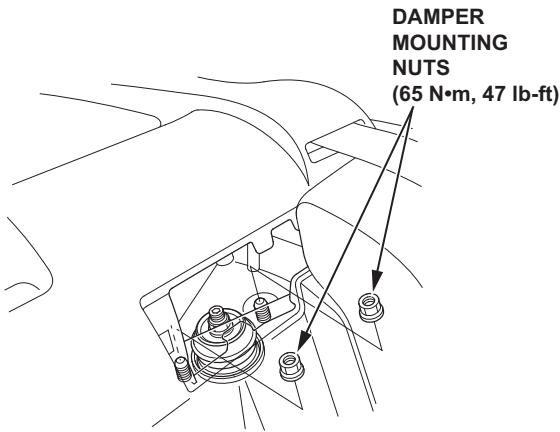

25. Loosely install the new damper lower mounting bolt on the bottom of the damper. Connect the stabilizer link to the brake hose bracket to the knuckle, and loosely install the new self-locking nut.

26. Place a floor jack under the connecting point of the knuckle and the lower arm, and raise the suspension to load the vehicle's weight.

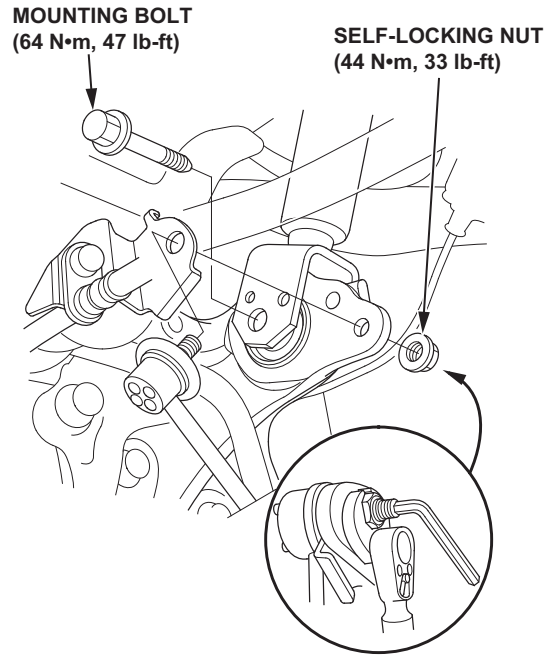

27. Torque the damper mounting bolt to 64 N·m (47 lb-ft).
28. Torque the stabilizer link to 44 N·m (33 lb-ft).
29. Torque the damper mounting nuts to 55 N·m (41 lb-ft).
30. Install the lid and the rear seat-back.
31. Reinstall the wheels and torque the wheel nuts to 108 Nm (80 lb-ft).
32. Check the wheel alignment (toe) and adjust as necessary.

	Front	Rear
Camber	$-25' \pm 30'$	$-2^{\circ} 22' \pm 30'$
Caster	$4^{\circ} 13' + 10' / -50'$	
Toe-in	$0 \pm 2 \text{ mm}$	$2 \pm 2 \text{ mm}$