



# INSTALLATION INSTRUCTIONS

Accessory  
**CD CHANGER ATTACHMENT KIT (REAR CONSOLE MOUNT)**

Application  
**2007 S2000**

Publications No.  
**All 33372**  
Issue Date  
**AUG 2006**

## PARTS LIST

**CD Changer Attachment Kit:  
P/N 08B26-S2A-100B**

Right bracket

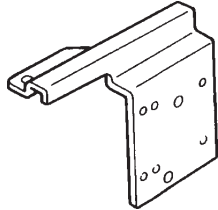

Left bracket

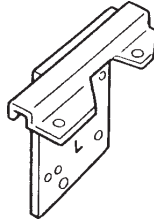

Upper panel

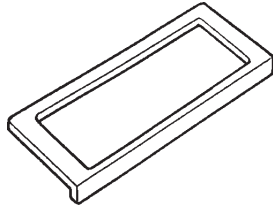

10 Wire ties

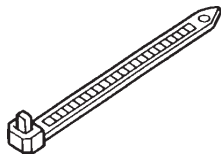

2 EPT sealers

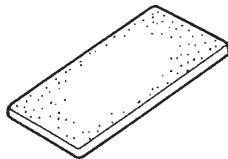

8 Washer-screws, 4 x 8 mm



BUS cable

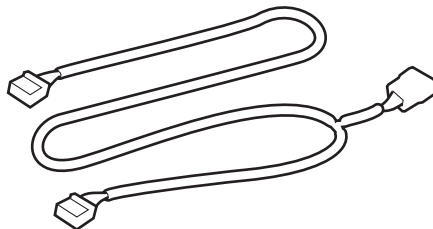

Wire tie with clip  
(for XM Radio equipped model only)

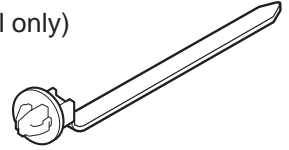

**CD Changer (sold separately):  
P/N 08A26-5E1-100**

CD changer

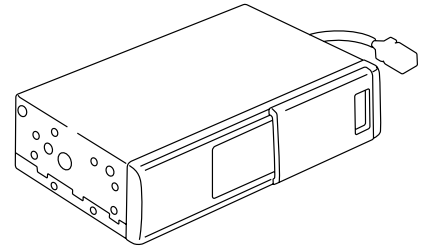

Side bracket  
(not used)

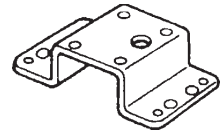

8-Disc CD magazine

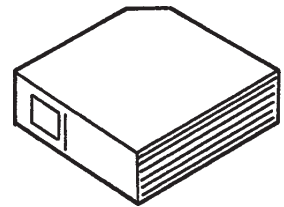

8 Washer-screws, 4 x 6 mm  
(Not used)



Accessory user's  
information manual

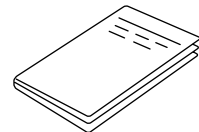

## TOOLS AND SUPPLIES REQUIRED

Phillips screwdriver  
Small, flat-tip screwdriver  
Ratchet  
10 mm Socket  
10 mm Combination wrench  
Diagonal cutters  
Utility knife  
Tape measure  
Felt-tip pen

### *Illustration of the CD Changer Console Attachment Installed on the Vehicle*

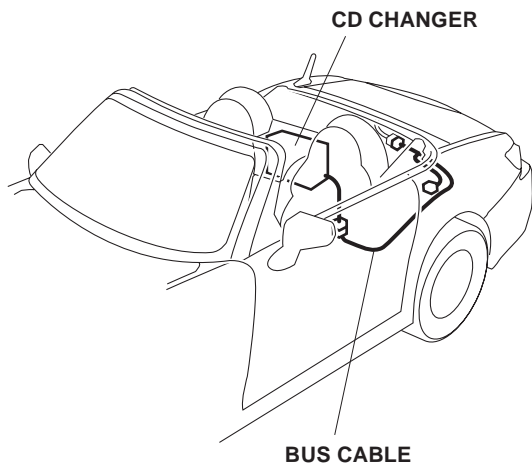

## INSTALLATION

**Customer Information:** The information in this Installation Instruction is intended for use only by skilled technicians who have the proper tools, equipment, and training to correctly and safely add equipment to your vehicle. These procedures should not be attempted by "do-it-yourselfers."

1. Make sure you have the anti-theft code for the radio, then write down the radio station presets.
2. Disconnect the negative cable from the battery.
3. Tilt the driver's side seat-back forward.

4. To remove the seat-back cover, open the caps of the two hooks, undo the two bolts, and remove the hooks. Release the five clips, then apply finger pressure under the cover, and pull it out.

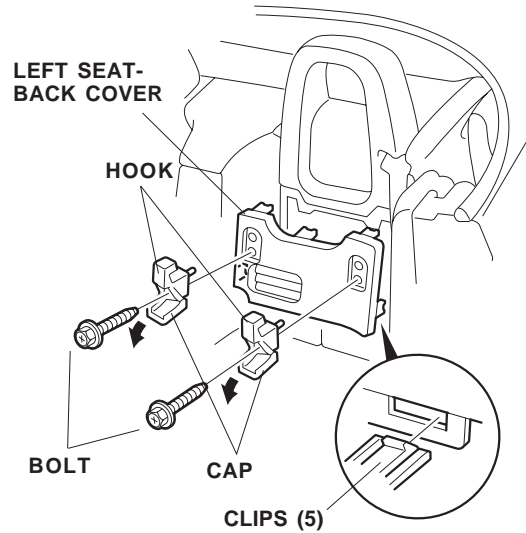

5. Open the trunk lid, and remove the tool tray.

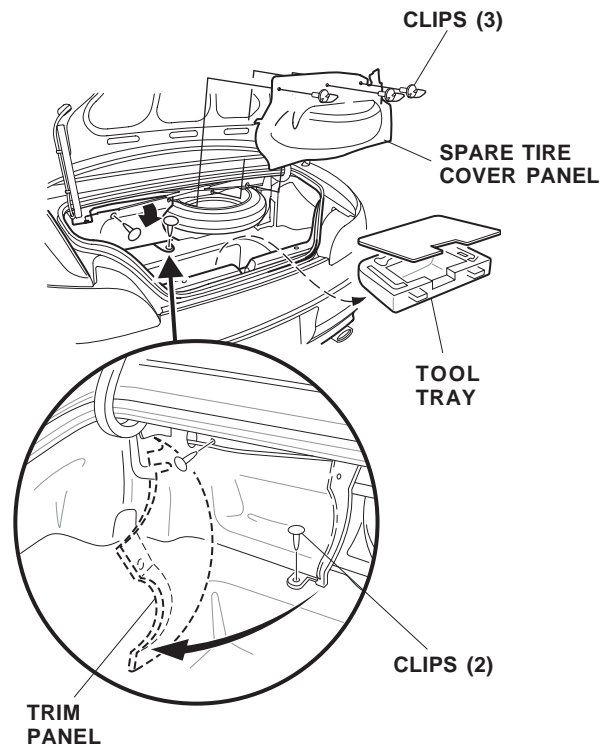

6. Remove the two clips that secure the left trunk side trim panel, and move the trim panel aside. Remove the spare tire cover panel (three clips).

- Using a utility knife, cut out the area on the left of the console box as indicated by the scribed lines.

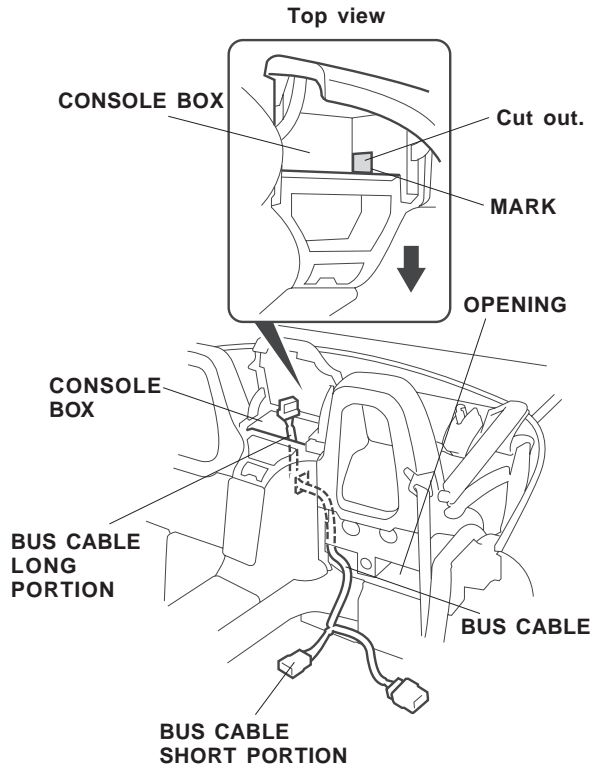

- Route the short portion of the bus cable down through the square hole you just made.

## Installing the CD changer

- Remove the three tapes from the CD changer, and remove and save the protective wrap.

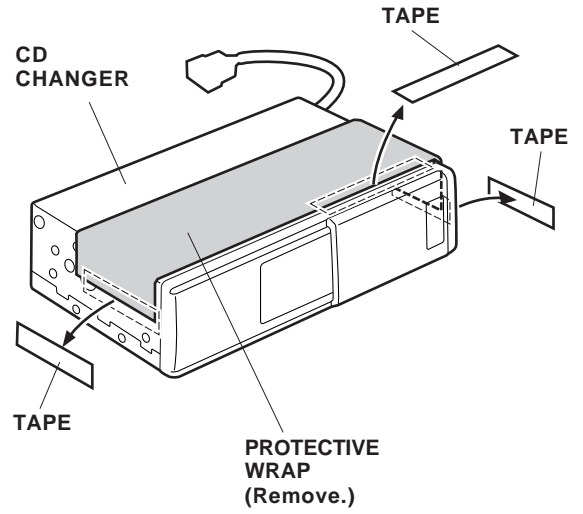

- Visually check that the spring adjusting slots on the sides of the CD changer are in the VERTICAL (V) position. If the slots are in the HORIZONTAL (H) position, move them to the VERTICAL (V) position using a small, flat-tip screwdriver.

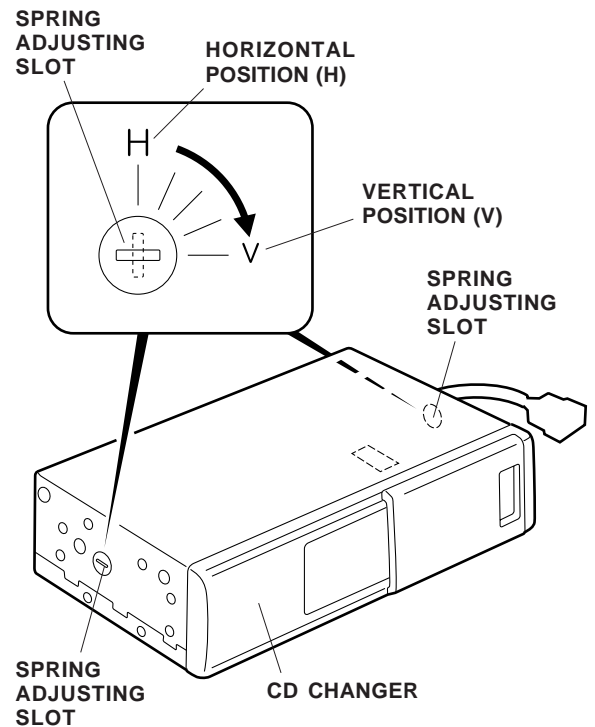

11. Position the right and left brackets on the sides of the CD changer, and install the two washer-screws on each bracket.

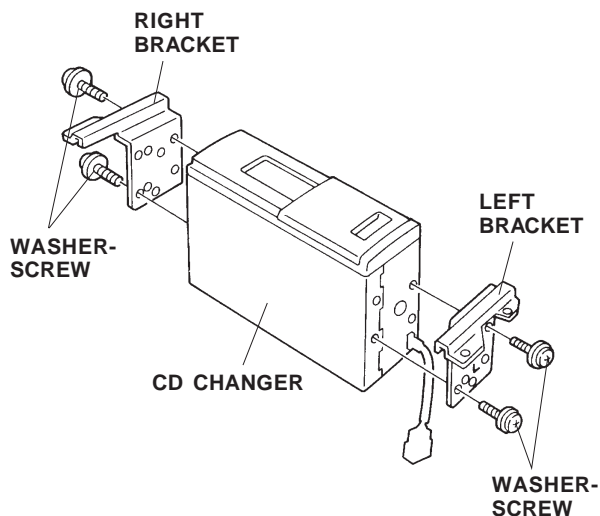

12. Remove the three self-tapping screws that secure the console box. Retain the self-tapping screws.

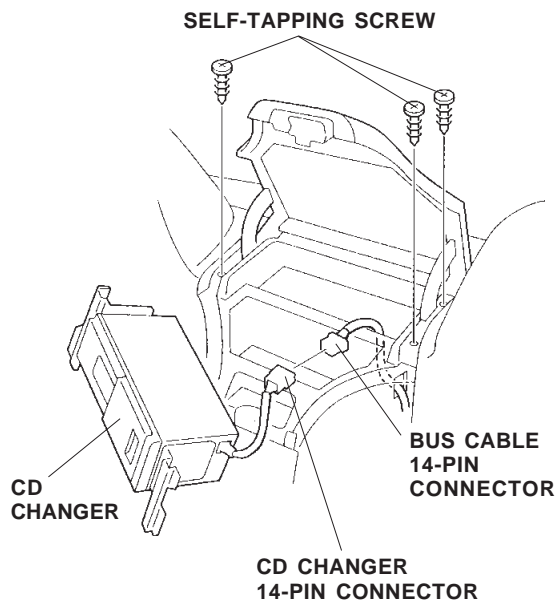

13. Connect the CD Changer 14-pin connector to the bus cable 14-pin connector.

14. Using scissors, cut the protective wrap (from step 9) in half, then wrap the halves around the right and left stays.

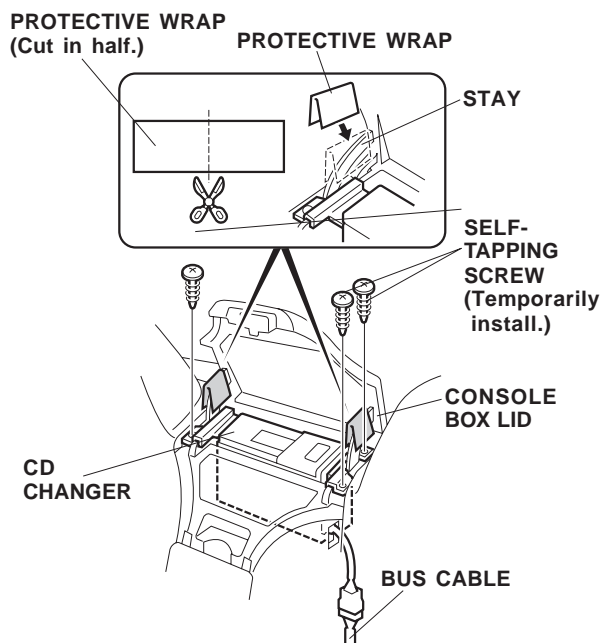

15. While pulling the BUS cable down and out, install the CD changer in the console box. Loosely secure it in place with the three self-tapping screws retained in step 12. Do not tighten the self-tapping screws yet.

- Remove the adhesive backing from the back of the upper panel, then attach the panel to the CD changer. Tighten the three self-tapping screws installed in step 15.

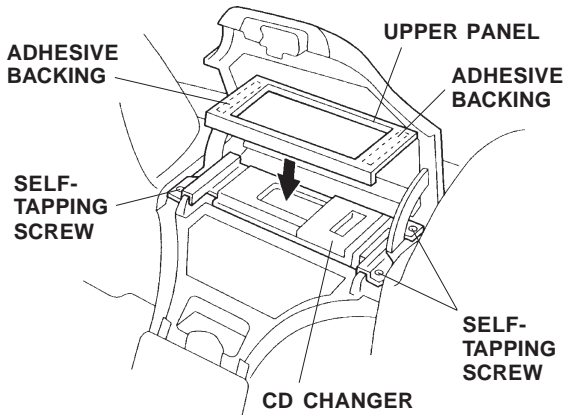

- Wrap the EPT sealer around the connectors (from step 13), then secure the connectors to the vehicle harness with one wire tie.

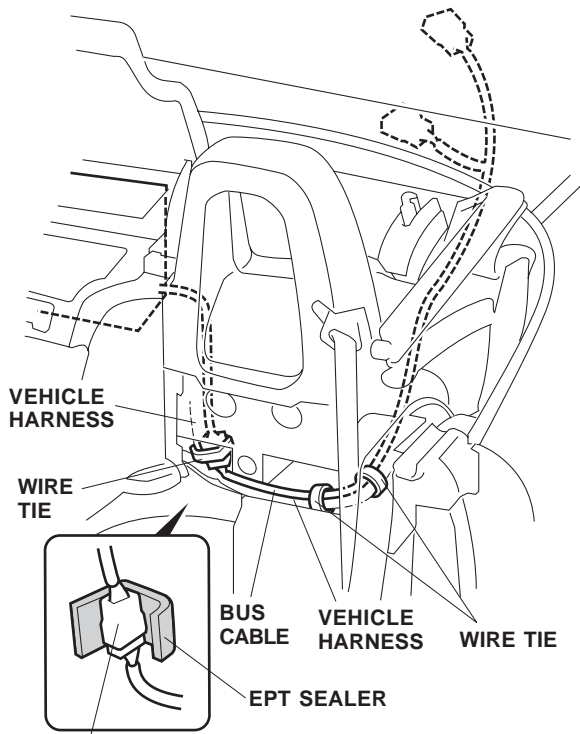

**CD CHANGER AND BUS CABLE CONNECTORS**  
(Connected in step 13.)

- Route the bus cable to the rear through the seat-back cover opening, then secure it to the vehicle harness with two wire ties in the areas shown. Do not route the bus cable near the fuel line.

- Route the bus cable into the trunk along the vehicle harness.

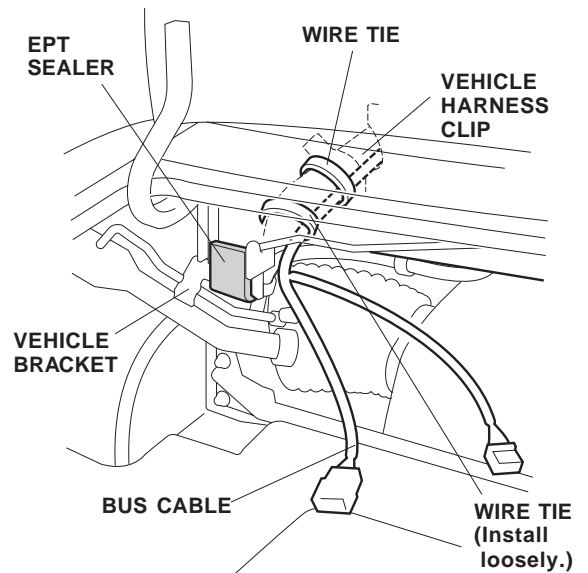

- Secure the bus cable with one wire tie to the side of the vehicle harness clip in the area shown.
- Loosely attach the bus cable to the vehicle harness with one additional wire tie in the area shown.

## Routing the Bus Cable

**NOTE:** If the vehicle is equipped with an XM radio, go to step 30; otherwise, continue with step 22.

22. Remove the vehicle clip with wire tie from the fuel tank, and cut the vehicle clip with wire tie. Take care not to damage the vehicle harness when cutting the wire tie.
23. Cut the tape from the vehicle subharness, and free the harness. Remove the connector cap from the subharness connector.

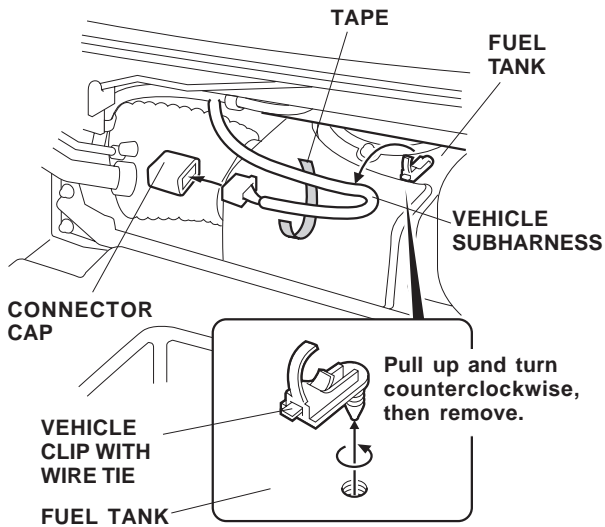

24. Connect the bus cable 14-pin connector into the vehicle subharness 14-pin connector.

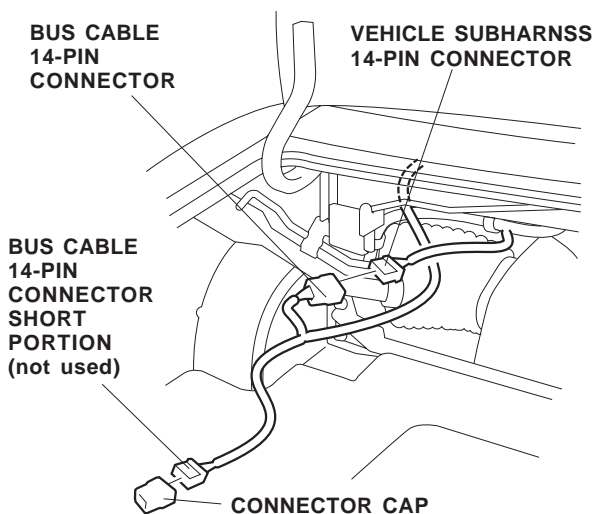

25. Install the connector cap removed in step 23 to the short portion of the bus cable 14-pin connector.
26. Route the short portion of the bus cable up through the wire tie you loosely attached in step 21 to the vehicle harness.

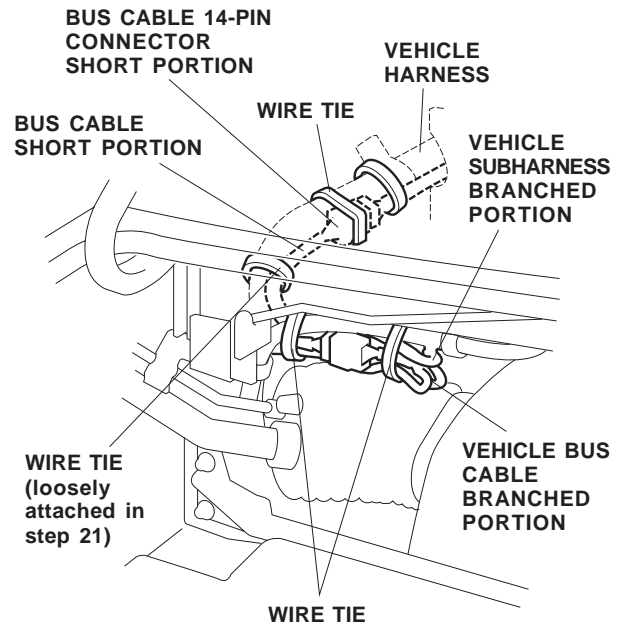

27. Align the branched portion of the bus cable with the vehicle subharness; loop the bus cable, and secure it to the vehicle harness with two wire ties.
28. Route the bus cable 14-pin connector (short portion) through the wire tie you loosely attached in step 21, and secure the 14-pin connector with one wire tie. Now tighten the other wire tie that you loosely attached in step 21.

*NOTE: If the vehicle you're working on is not equipped with XM radio, go to step 36; otherwise, continue with step 29.*

29. Loosen the two bolts that fasten the XM radio.

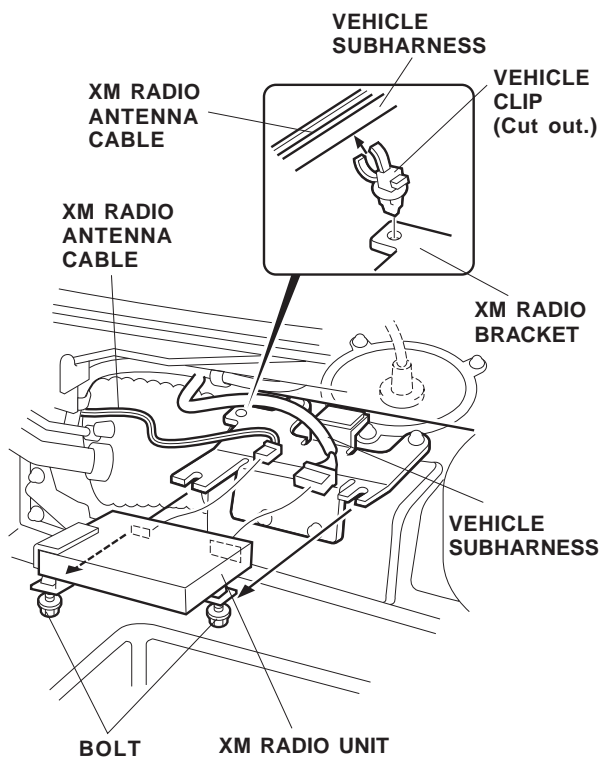

30. Pull the XM radio out toward you, and release the vehicle clip that fastens the vehicle subharness and the XM radio antenna cable from the XM radio bracket. Cut out the clip from the vehicle subharness and XM radio antenna.
31. Unplug the vehicle subharness and the XM radio antenna cable from the rear of the XM radio unit.

32. Connect the bus cable 14-pin connector to the vehicle subharness 14-pin connector, and connect the short portion of the bus cable 14-pin connector to the XM radio unit.

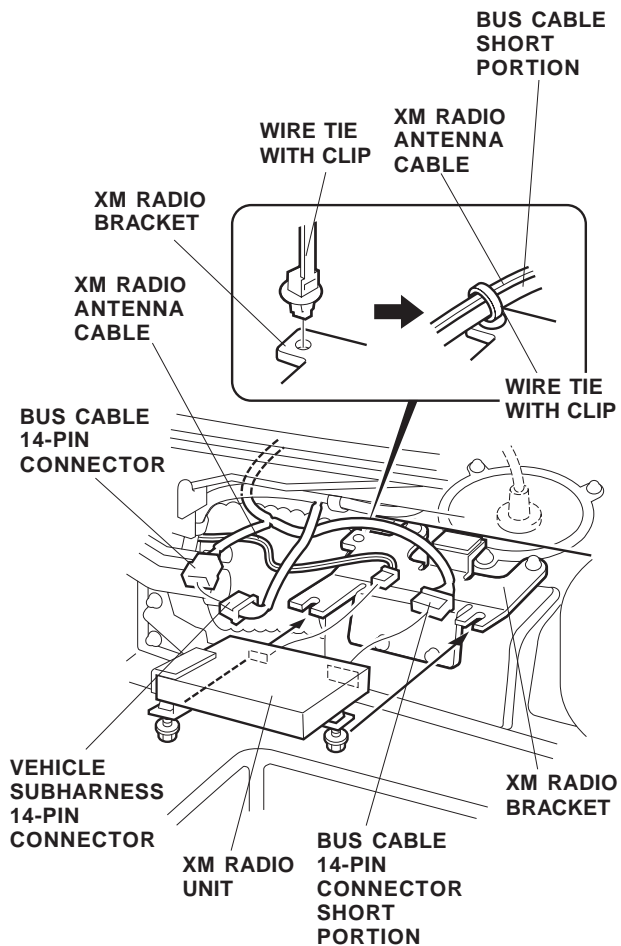

33. Plug the XM radio antenna jack into the rear of the XM radio unit, and secure it to the XM radio bracket with the wire tie with clip along with the short portion of the bus cable.
34. Reinstall the XM radio unit.

35. Align the branched portion of the bus cable. Loop the bus cable, and secure it to the vehicle harness with the wire ties in the areas shown.

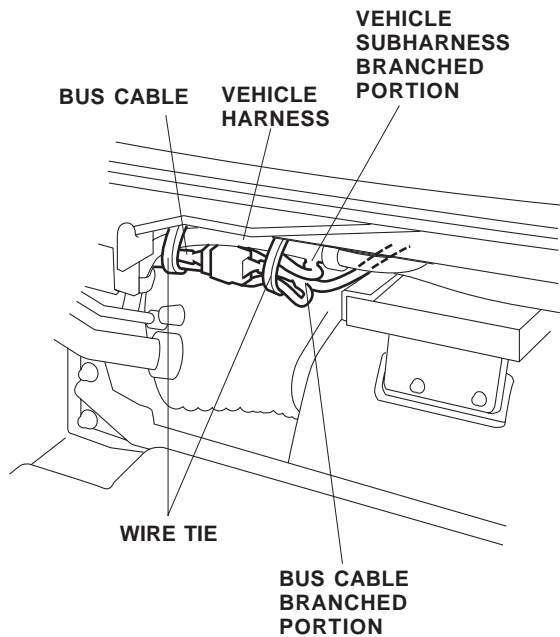

36. Check that all wire harnesses are routed properly and all connectors are plugged in.
37. Reconnect the negative cable to the battery.
38. Enter the customer's radio anti-theft code, and reset the radio station presets.
39. Reset the clock.
40. Check operation of the CD Changer according to the owner's manual provided.