



INSTALLATION INSTRUCTIONS

Accessory

FRONT UNDER SPOILER

Application

2007 ODYSSEY

Publications No.

All 33173

Issue Date

JULY 2006

PART LIST

Front under spoiler

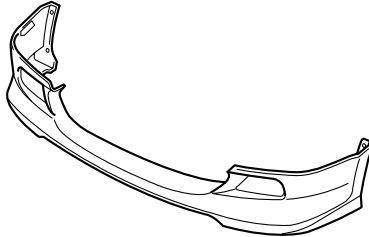

5 Stepped bolts

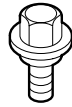

2 Square head bolts



2 Washer-nuts



4 Self-tapping screws



4 Spring nuts



TOOLS AND SUPPLIES REQUIRED

Phillips screwdriver

Flat-tip screwdriver

Ratchet

10 mm Socket

Drill

3 mm, 6 mm, 8 mm and 10 mm Drill bits

Center punch

File

Blanket

Masking tape

Isopropyl alcohol

Shop towel

Eye protection (face shield, safety goggles, etc.)

INSTALLATION

Customer Information: The information in this installation instruction is intended for use only by skilled technicians who have the proper tools, equipment, and training to correctly and safely add equipment to your vehicle. These procedures should not be attempted by "do-it-yourselfers."

NOTE:

- Be careful not to damage the front bumper and body paint finish.
- This front under spoiler kit should be installed only if the ambient air temperature is 60°F (15°C) or above.
- To allow the adhesive to "cure", do not wash the vehicle for 24 hours.

1. Remove the front bulkhead cover (ten clips).

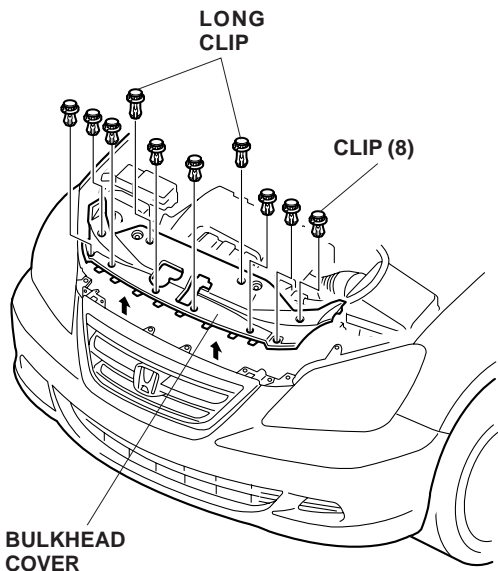

With Fog Lights:

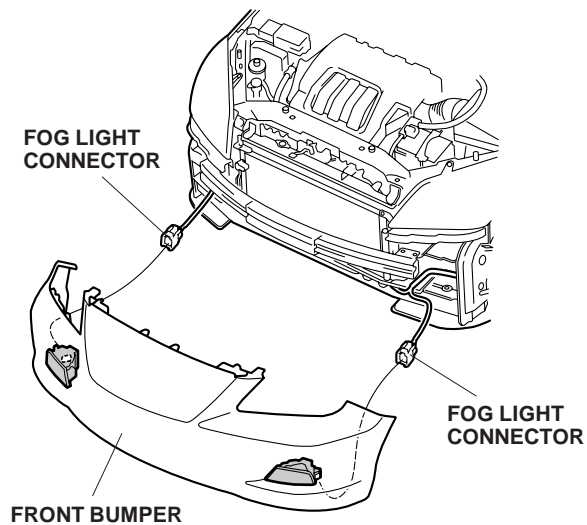

2. Remove the front bumper (two bolts, eight clips, and two self-tapping screws and pull the bumper out towards you). If equipped, unplug the fog light connectors. If equipped, unplug the front corner sensor connectors. Place the front bumper on a blanket to install the front under spoiler.

Without Fog Lights and Front Corner Sensors:

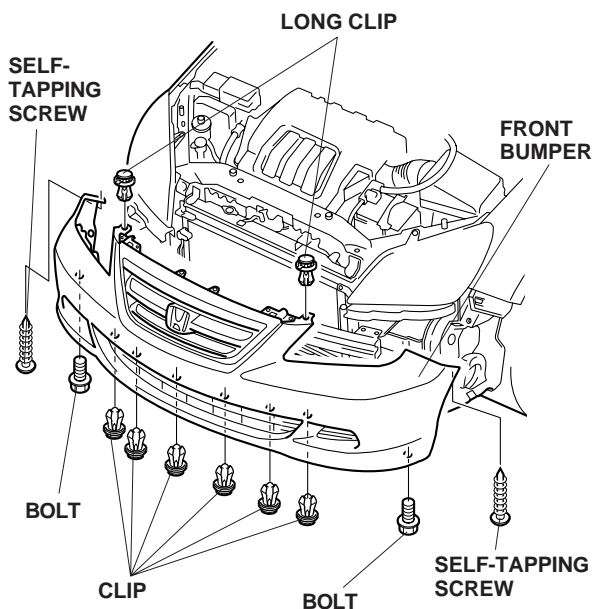

With Front Corner Sensors:

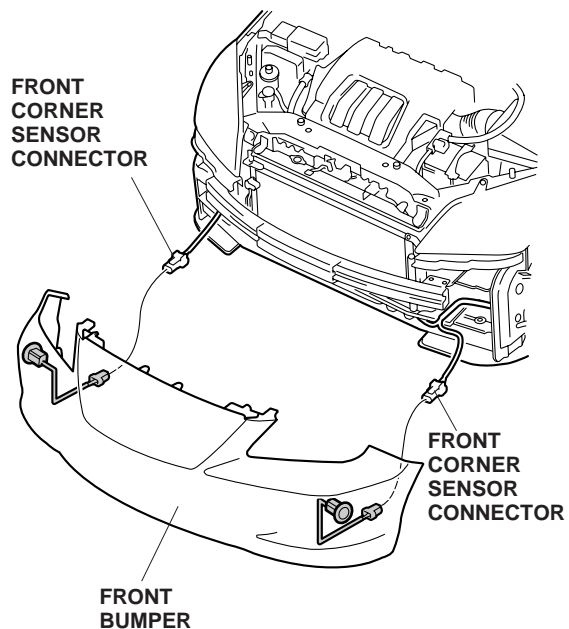

3. Locate the four dimples at the fenderwell area of the front bumper. While wearing eye protection, drill a 6 mm hole through each dimple. Start with a 3 mm drill bit and finish with a 6 mm drill.

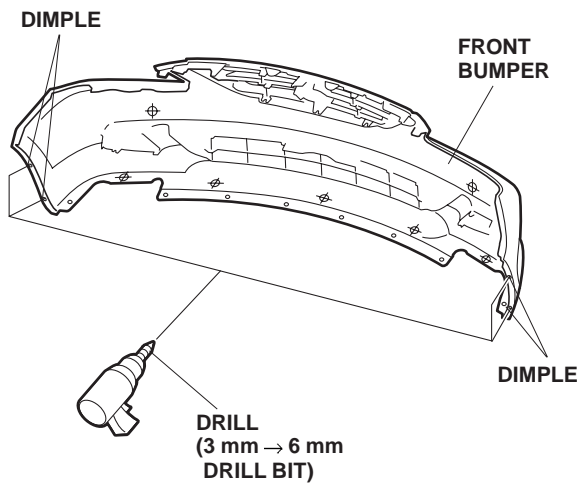

4. On the inside of the bumper, locate the seven scribed marks. Center punch each scribed mark.

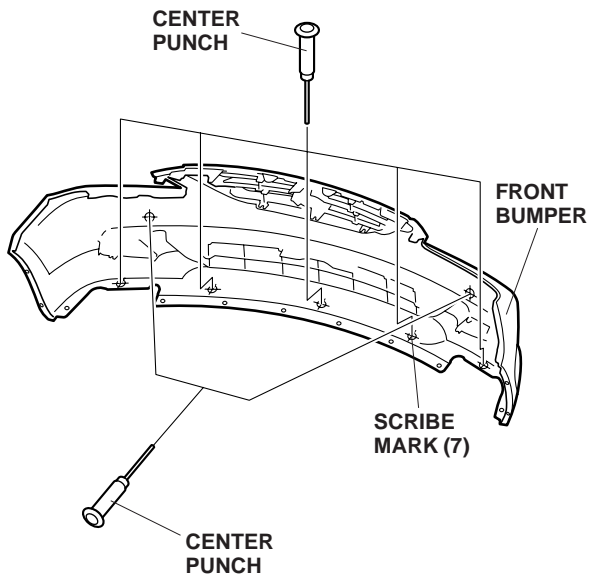

5. While wearing eye protection, drill two 8 mm holes through the front bumper. First drill with a 3 mm drill bit, then finish with an 8 mm drill bit.

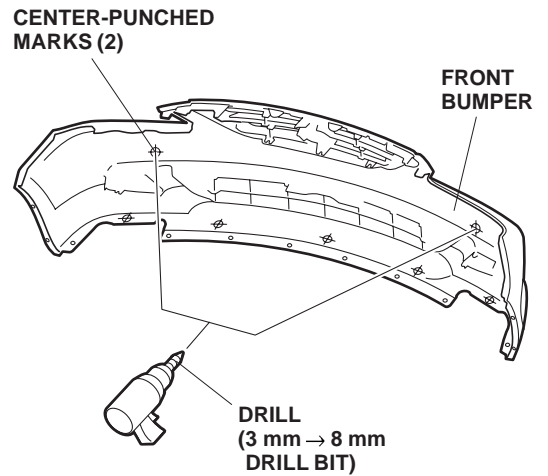

6. While wearing eye protection, drill five 10 mm holes through the five center-punched marks along the bottom of the bumper. First drill with a 3 mm drill bit, then with a 6 mm drill bit, and finish with a 10 mm drill bit.

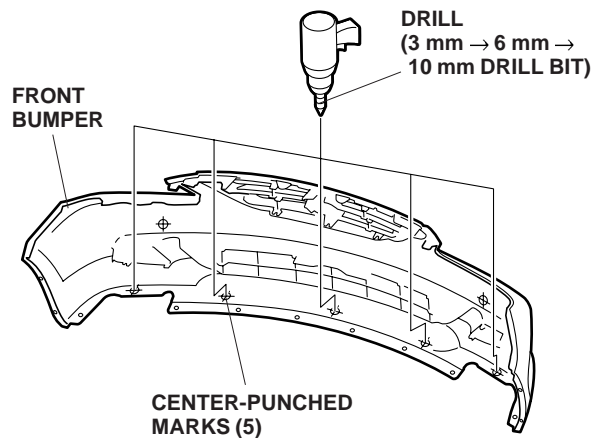

7. Using a file, remove any burrs from the drilled holes.

- Slide one spring nut over each of the four holes you drilled at the fenderwell area of the bumper.

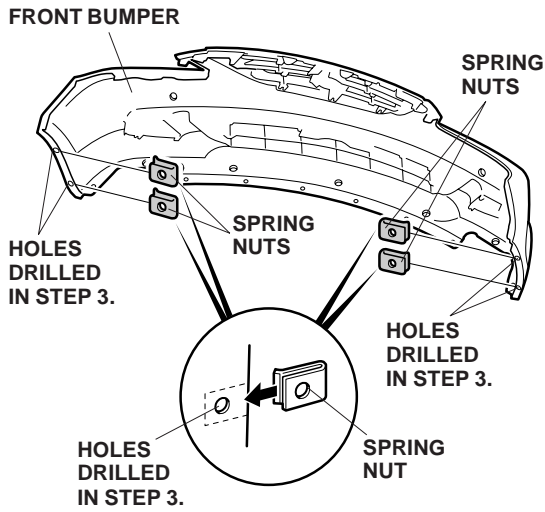

- Slide one square head bolt into each bracket on the front under spoiler.

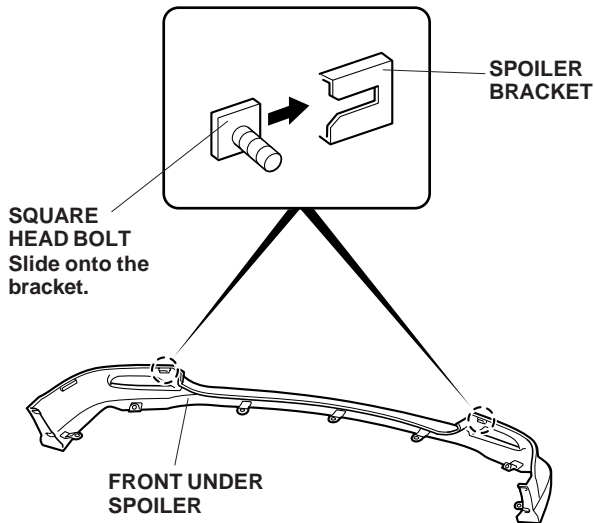

- Attach a strip of masking tape to the end of each adhesive backing, then pull back 1½ to 2 inches of the adhesive backing. Fold the ends back, and tape them to the front of the spoiler.

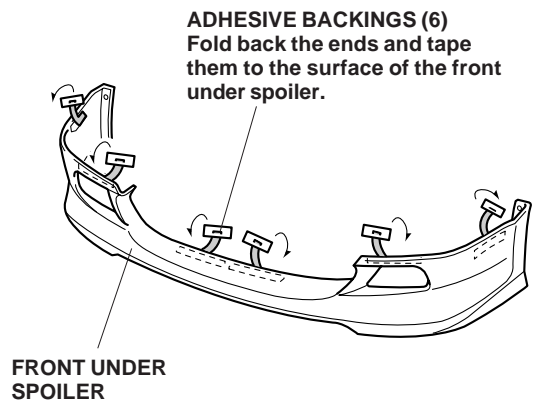

- Using isopropyl alcohol on a shop towel, clean the front bumper where the under spoiler will attach.
- Position the under spoiler on the front bumper, and install a washer-nut to each square-head bolt.

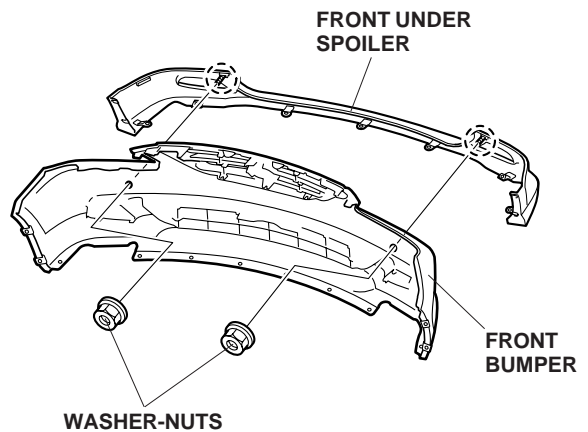

- Secure the front bumper to the front under spoiler using the five stepped bolts.

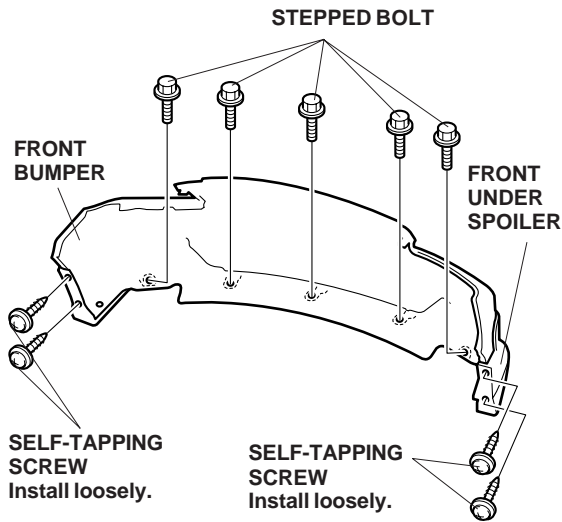

- At the edge of the spoiler/bumper, loosely install the four self-tapping screws.
- With the help of an assistant, gently pull the sides of the bumper around the fenderwell and install the front bumper. If equipped, plug in the fog light connectors. If equipped, plug in the front corner sensor connectors. Make sure the center rubber splash protector is above the bottom bumper edge. Reinstall the six clips, two bolts, and two self-tapping screws to secure the bumper.

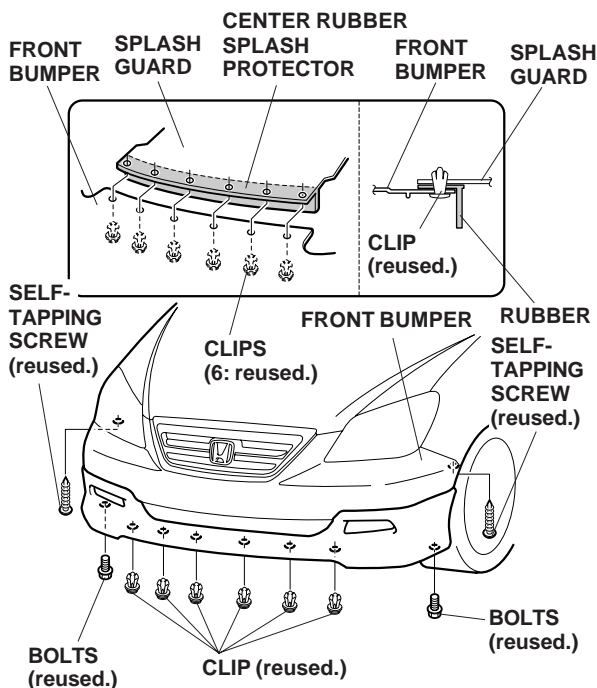

- While holding light pressure on the spoiler, carefully remove the adhesive backings. Hold the spoiler firmly against the front bumper with the palm of your hand for 30 seconds, particularly at the edges.

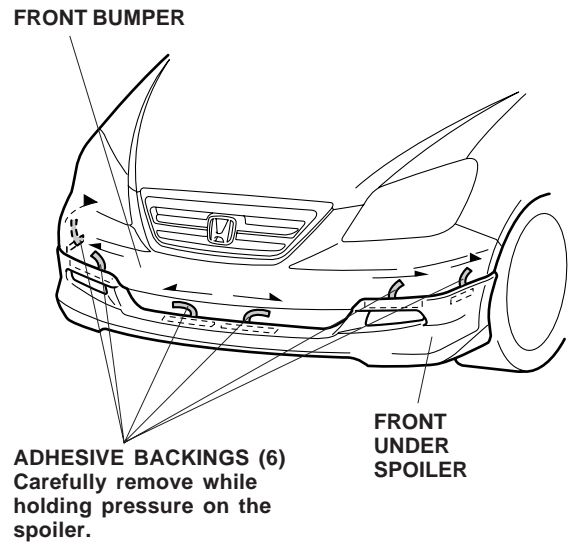

- While holding the edge of the spoiler against the bumper, tighten the four self-tapping screws installed in step 14.

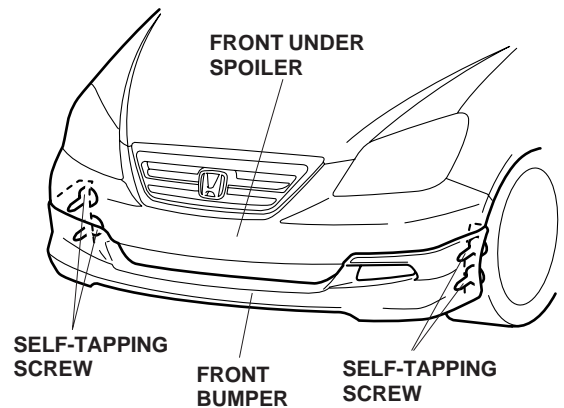

- Reinstall the front bulkhead cover.

Give a copy this page to your customer.

- When towing Odyssey, follow the instructions described in the vehicle Owner's Manual.
- When using the front towing hook, make sure to remove the front bumper with front under spoiler. Failure to follow this precaution could damage the vehicle, the front bumper, and the front spoiler.

