



INSTALLATION INSTRUCTIONS

Accessory

**STEERING WHEEL
P/N 08U97-SCV-100**

Application

2007 ELEMENT

Publications No.

All 33018

Issue Date

JULY 2006

PARTS LIST

Steering wheel



2 Torx bolts



4 Hex bolts



Information

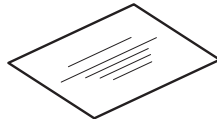

TOOLS REQUIRED

Phillips screwdriver
10 mm Combination wrench
Flat-tip screwdriver
14 mm T-handle wrench
Torque wrench
Steering wheel puller
T30 and T40 Torx bits

INSTALLATION

Customer Information: The information in this installation instruction is intended for use only by skilled technicians who have the proper tools, equipment, and training to correctly and safely add equipment to your vehicle. These procedures should not be attempted by "do-it-yourselfers."

NOTE: Observe all safety notes and precautions described in the Service Manual in addition to those described in this Installation Instruction.

1. Make sure you have the anti-theft code for the radio, then write down the frequencies for the preset buttons.
2. Disconnect the negative cable from the battery, and wait for at least 3 minutes before you start to install the new steering wheel.
3. Pry up on the retaining tabs, and remove the access panel from the underside of the driver's side airbag.

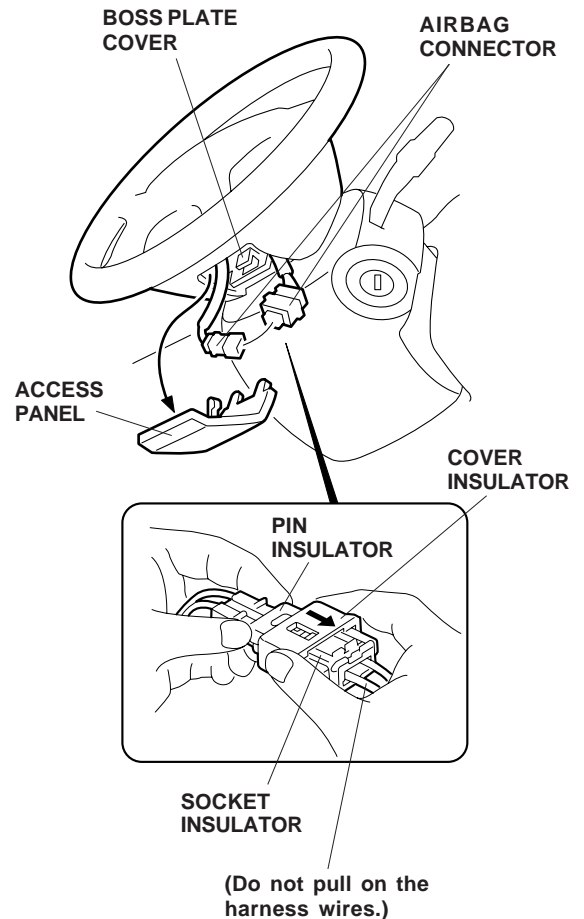

4. Remove the airbag connector from the boss plate cover. Unplug the airbag connectors; while holding the pin insulator, pull out on the cover insulator. Do not pull on the socket insulator.

- Remove and discard the two TORX bolts that secure the airbag, and remove the airbag. Carefully set the airbag in a secure location with the pad facing up. Do not drop or bump the airbag against anything.

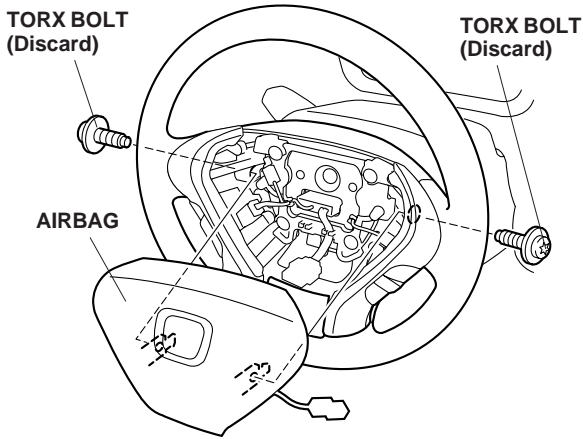

- Turn the steering wheel so the front wheels are in the straight-ahead position.
- If equipped, disconnect the radio remote and cruise switch connector.

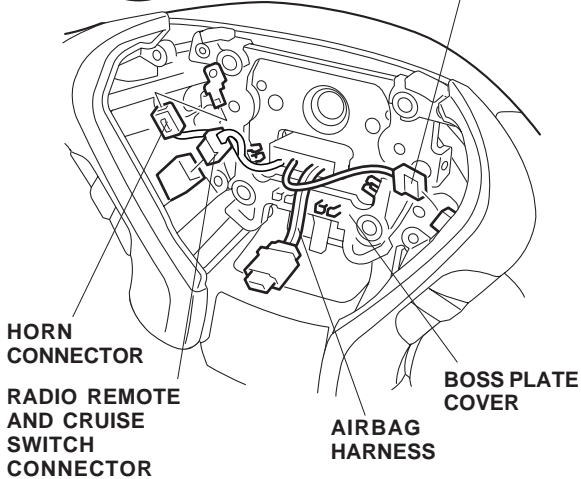

- Disconnect the auto cruise set switch con and the horn connector.
- Release all harnesses from the clips on the boss plate cover.

- Remove the steering wheel bolt, and remove the steering wheel. Be careful not to move the steering wheel during removal.

If a steering wheel puller is needed to remove the steering wheel, be careful not to thread the steering wheel puller bolts in more than 10 mm.

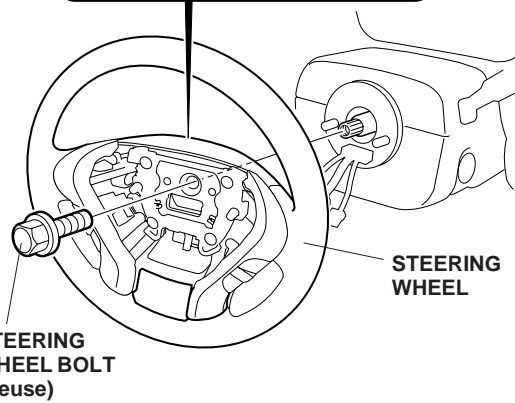
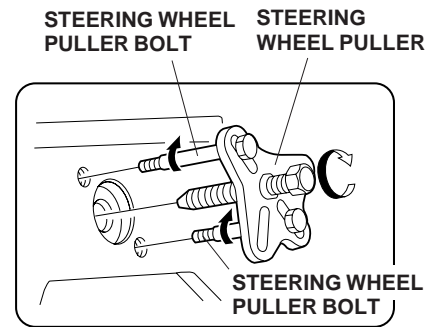

- Remove the four screws that fasten the right and left finishers. Release the hook and, remove the finishers.

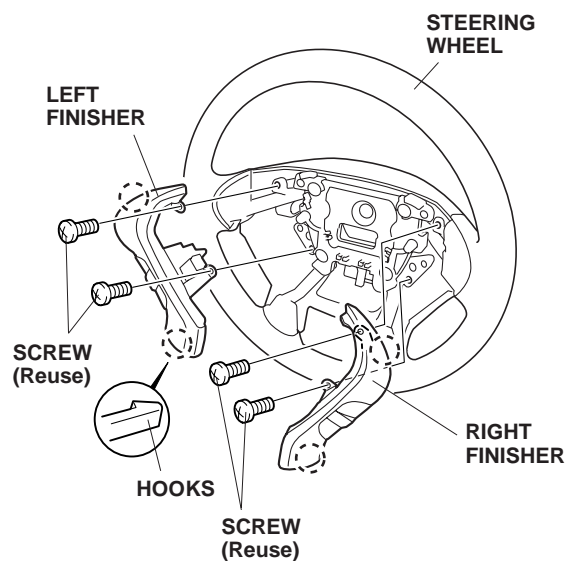

12. Remove the boss plate cover (4 Hex bolts with washers). Remove the four springs. Note the location of each spring.

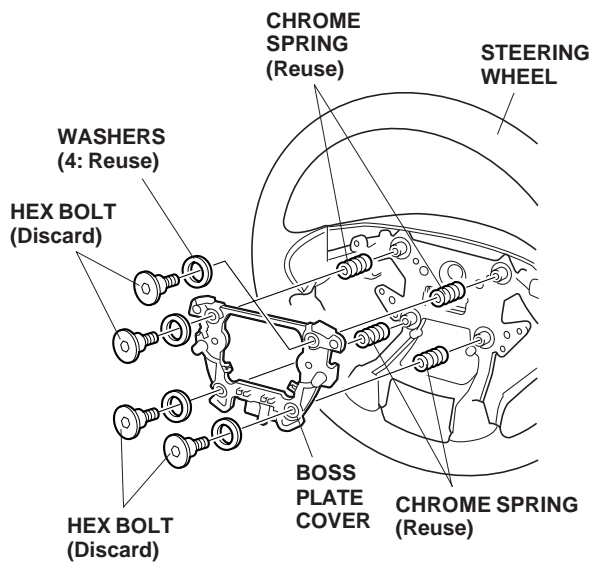

13. Remove the steering wheel body cover (four self-tapping screws).

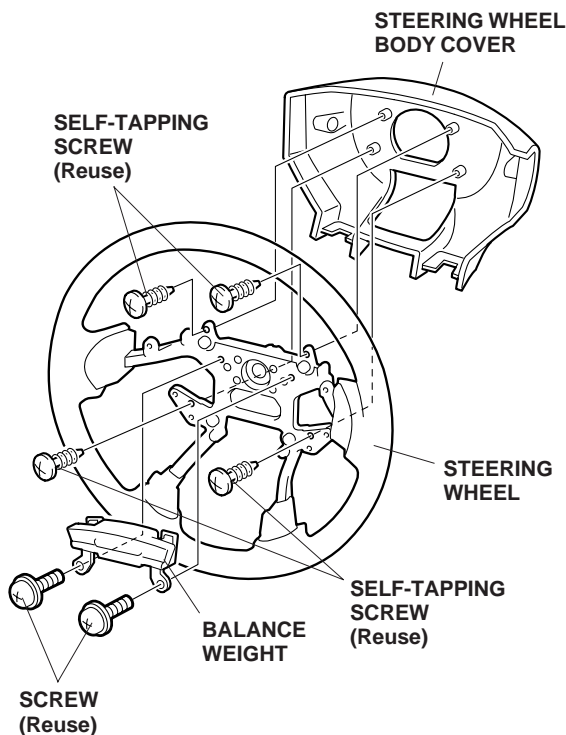

14. Remove the steering wheel balance weight (two screws).

15. Install the steering wheel balance weight removed in step 14 to the new steering wheel with the two screws (reuse).

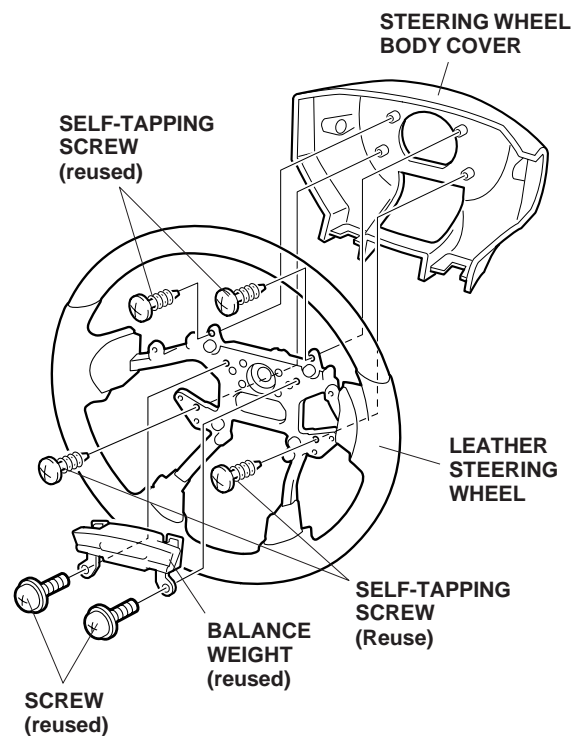

16. Install the steering wheel body cover removed in step 13 to the new steering wheel with the four self-tapping screws (reuse).

17. Position the four springs (reuse) on the new steering wheel, and install the boss plate cover removed in step 12 with the four Hex bolts supplied and four washers (reuse). Torque the bolts to 4 to 5 N·m (3 to 4 lb-ft).

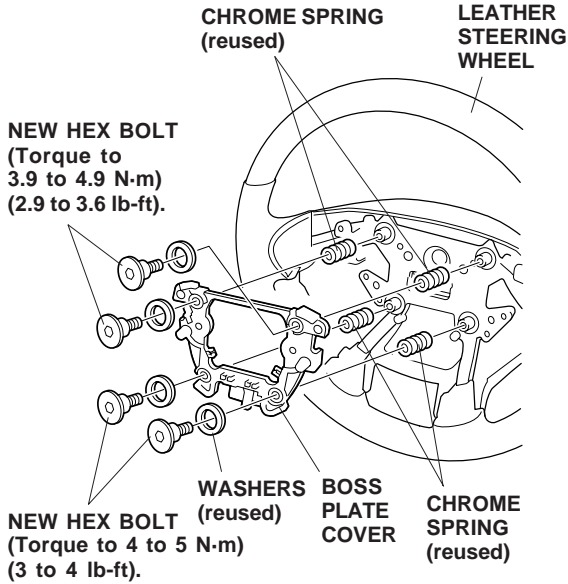

18. Install the right and left finishers removed in step 11 to the new steering wheel using the four screws (reuse).

- Align the tab of the finishers with the hole in the steering wheel as shown.
- Take care not to damage the hooks.

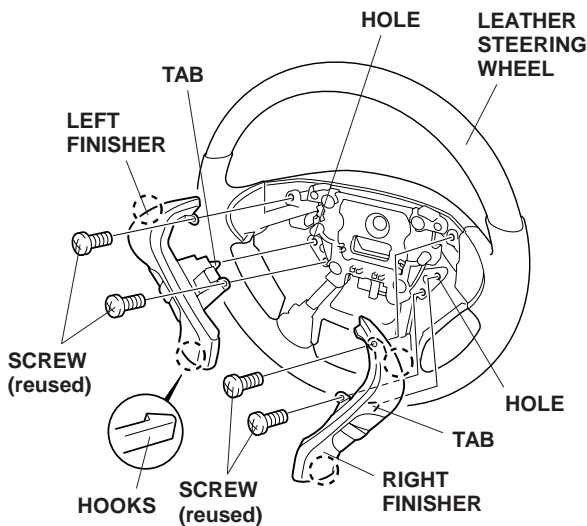

19. Install the new steering wheel on the steering column shaft in the straight-ahead position:

- Route the wire harnesses through the opening in the wood trim steering wheel.
- Align the two tabs of the canceling sleeve with the two cutouts in the steering wheel as shown.
- Check that the wire harnesses are not pinched.

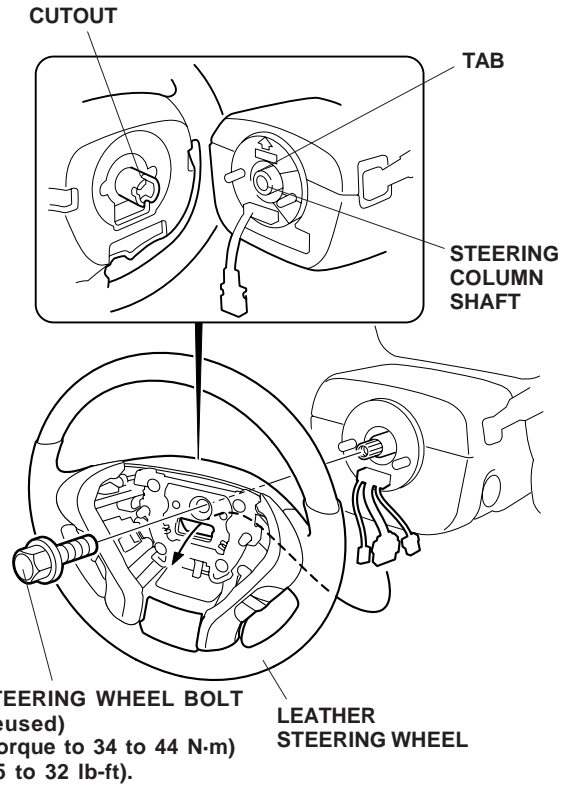

20. Install the steering wheel bolt (reuse). Torque the steering wheel bolt to 34 to 44 N·m (25 to 32 lb-ft).

21. If equipped, plug with radio remote and cruise control plug in the connector for the radio remote and cruise switch.

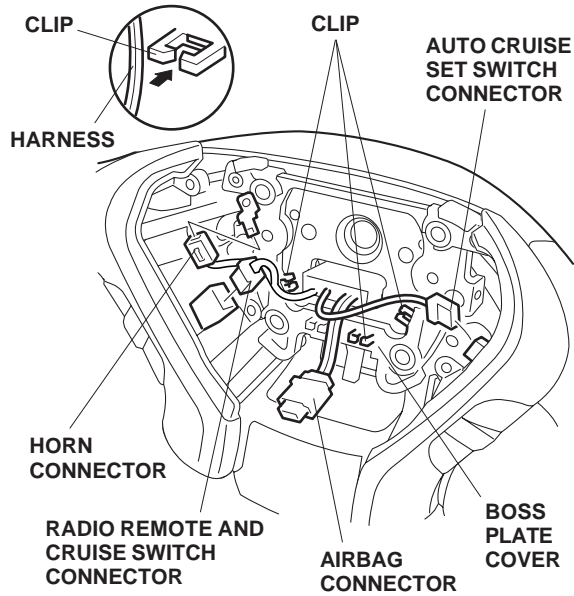

22. Plug in the connector for the auto cruise set switch, and connect the horn connector as shown.
23. Attach all harnesses to the clips on the boss plate cover.

24. Get the airbag removed in step 5, and route the airbag harness down through the steering wheel. Position the airbag on the new wheel, and install the two TORX bolts supplied. Torque the TORX bolts to 10 N·m (7 lb-ft).

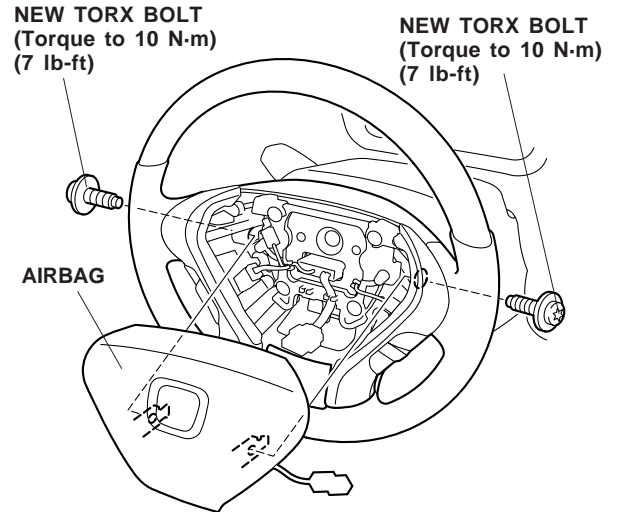

25. Connect the airbag harness connectors:

- Push the socket insulator onto the pin insulator until it contacts the tab on the pin insulator.
- Do not push the socket insulator onto the pin insulator by pushing on the cover insulator.
- Continue pushing on the socket insulator in the same direction until the cover insulator rides over the tab on the pin insulator and is locked securely.
- Reattach the airbag harness connector to the boss plate cover.
- Reinstall the access panel.

26. Reconnect the negative cable to the battery.

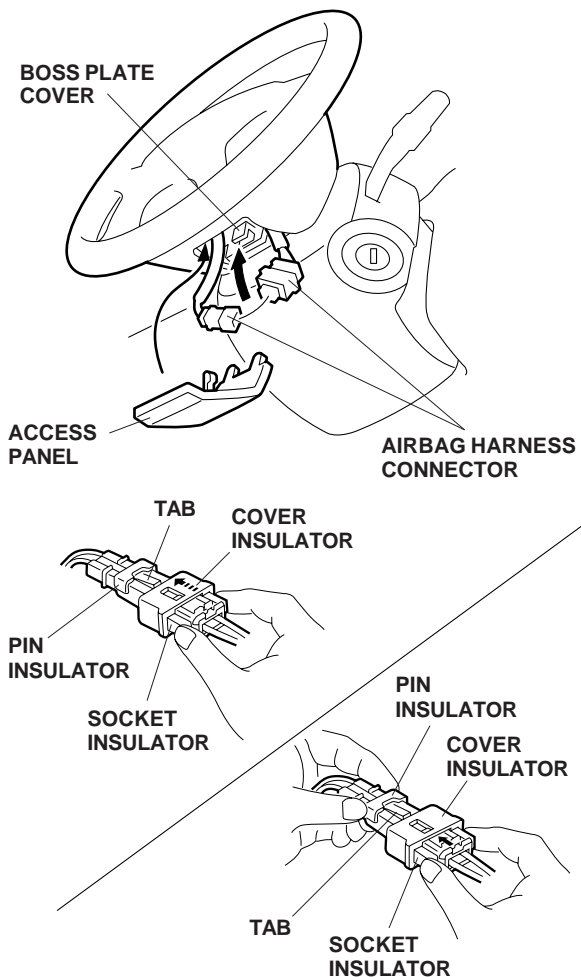

27. Make sure the steering wheel is in the straight-ahead position with the front wheels. If the spoke angle of the steering wheel is not in the straight-ahead position with the front wheels, adjust the front toe as described in the Service Manual.

28. Verify that the horn works.

29. Turn the ignition key on, and verify that the SRS warning light comes on and stays on for 6 seconds; turn the key off to make sure the SRS warning light goes off.

30. Enter the customer's radio anti-theft code, and reset the radio station presets.

31. Reset the clock.

NOTE: When the battery is disconnected, the driver's window AUTO function is disabled.

32. Start the engine. Push down on the driver's window switch until the window is fully open.

33. Pull up on the driver's window switch fully to close the window completely, then hold the switch for 2 seconds or more.

34. Test the window AUTO function.