

Put this information in the glove box with the vehicle owner's manual.

PARTS LIST

Mask
(hood section)

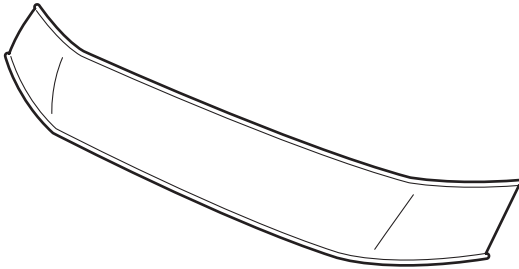

Left side mask
(fender section)

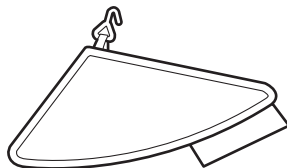

Right side mask
(fender section)

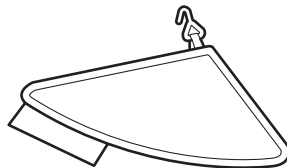
**INSTALLATION****NOTE:**

- Make sure the vehicle and the nose mask are clean and completely dry before installation. If moisture under the mask is allowed to dry, it may cloud the paint. If the mask gets wet, remove it and allow it to air-dry completely.
- Make sure any repainted surfaces are cured.
- Make sure the hood and nose of the vehicle have been waxed with a high-quality paste wax.
- Make sure to install the nose mask securely. If the nose mask starts to flap or comes loose while driving, safely pull off the highway, stop the vehicle, and secure or remove the mask.

Installing the Hood Section

1. Open the hood. Fit the corners of the mask around the hood. Adjust the mask so that it fits smoothly over the edges. Attach the "S" hooks to the hood in the areas shown.

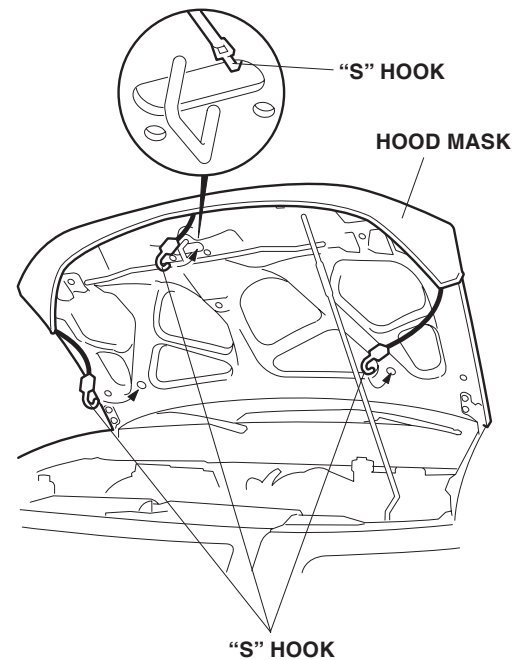

Installing the Fender Section

2. Slip the pocket of the mask's fender section onto the front corner of the fender. Attach the "S" hook to the hole in the fender. Insert the tab between the left front cladding and front fender as shown.

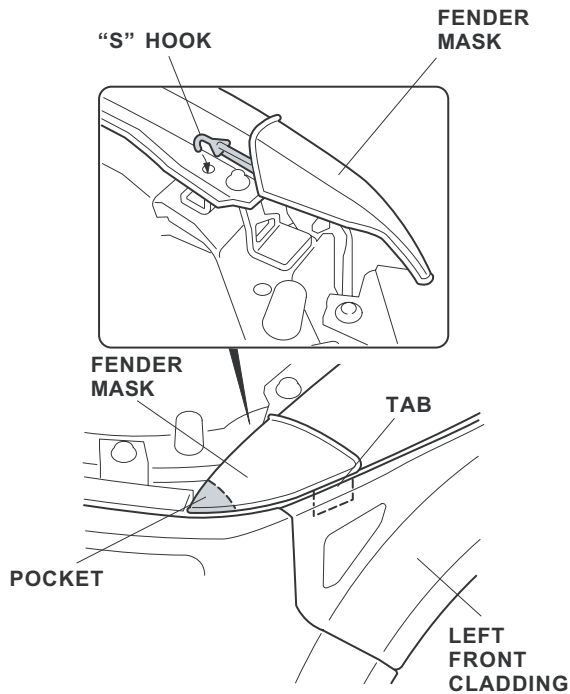

3. Attach the right side mask to the right fender the same way.
4. Put these instructions in the glove box.

CLEANING THE NOSE MASK

Use a sponge or cloth and a solution of mild liquid dishwashing soap and water to clean the vinyl and the flannel backing. Rinse the mask completely with clean water, and hang it to dry out of direct sunlight. Make sure the mask is completely dry before you reinstall it.