



INSTALLATION INSTRUCTIONS

Accessory

**FOG LIGHTS
P/N 08V31-SCV-100B**

Application

**2007 ELEMENT
(SC)**

Publications No.

All 33017

Issue Date

SEP 2006

PARTS LIST

Right fog light

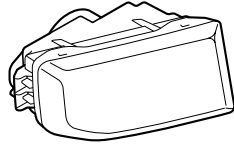

Left fog light

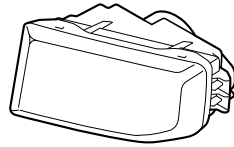

Right fog light bracket

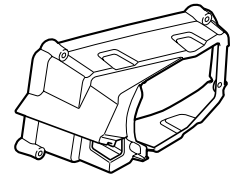

Left fog light bracket

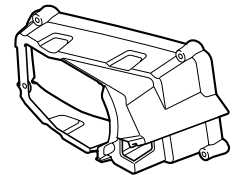

Right sub-bracket



Left sub-bracket



Switch harness

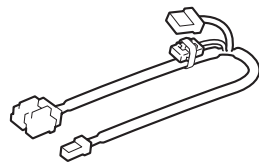

Fog light harness

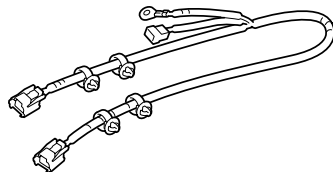

Relay bracket

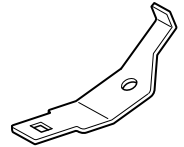

Relay

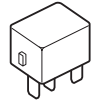

Fuse label



17 Wire ties

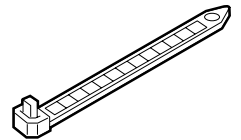

2 Wire ties with clip

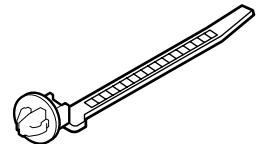

8 Self-tapping screws



3 Washer-bolts

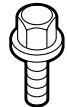

Flange nut



Switch

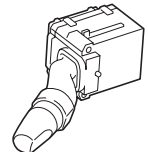

2 Grommets



2 Self-tapping washer-screws



Clip

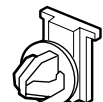

TOOL AND SUPPLIES REQUIRED

Phillips screwdriver
Flat-tip screwdriver
Ratchet
8 mm and 10 mm sockets
File
Utility knife
Clip remover
Masking tape
Eye protection (face shield, safety goggle, etc.)

Illustration of the Fog Light Installed on the Vehicle

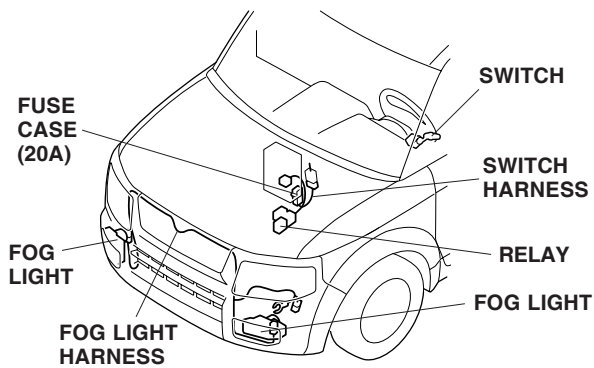

INSTALLATION

Customer Information: The information in this installation instruction is intended for use only by skilled technicians who have the proper tools, equipment, and training to correctly and safely add equipment to your vehicle. These procedures should not be attempted by “do-it-yourselfers.”

NOTE: These installation instruction show the left fog light being installed. The same procedure applies to installing the right fog light.

1. Make sure you have the anti-theft code for the radio, then write down the frequencies for the preset buttons.
2. Disconnect the negative cable from the battery.

Installing the Fog Light

3. Open the hood and remove the radiator cover (five clips).

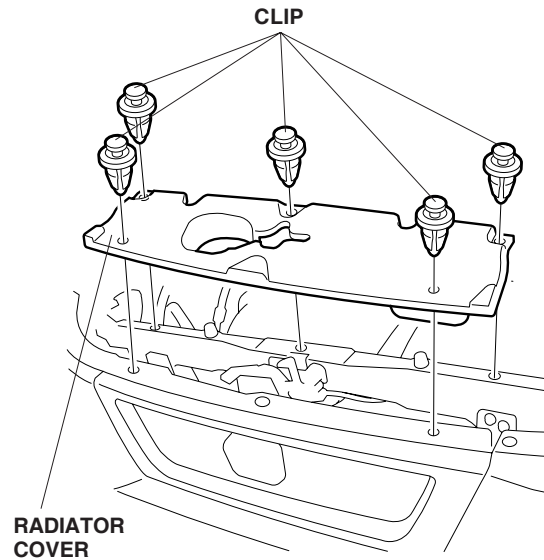

4. With the help of an assistant, remove the front bumper (seven clips at the top, four clips and four stepped bolts at the bottom, one self-tapping washer-screw on each side and one self-tapping screw on each side).

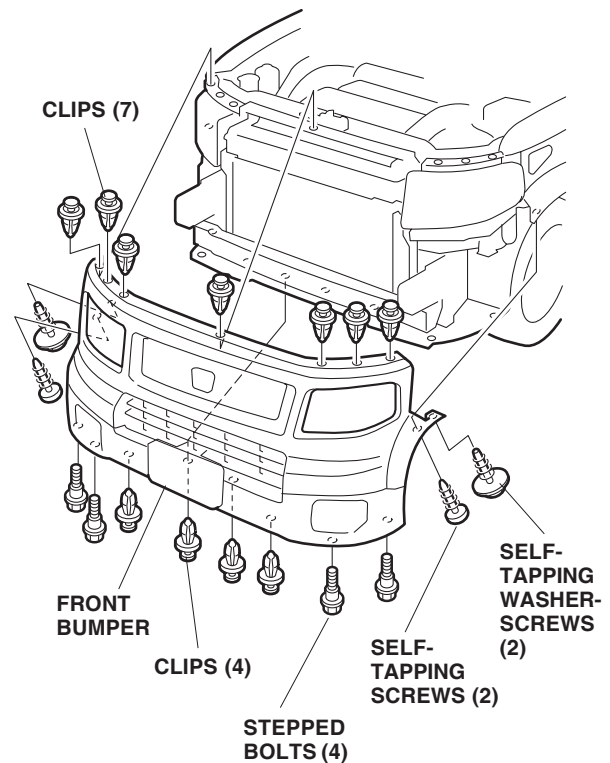

5. Apply masking tape to the front bumper in the area shown.

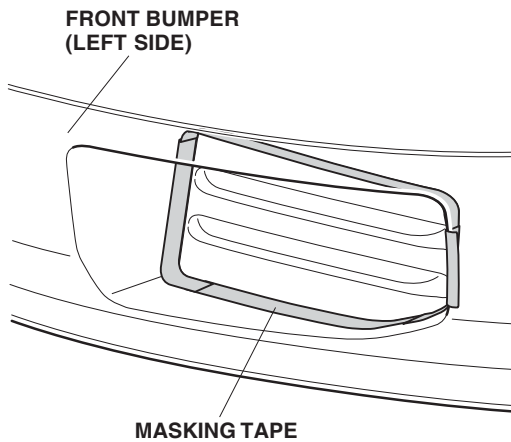

6. Inside the front bumper, locate the slit on the fog light housing on the left side. Using a utility knife, cut out the marked area from the front bumper along the groove on the back. Remove all burrs from the edges of the cutout.

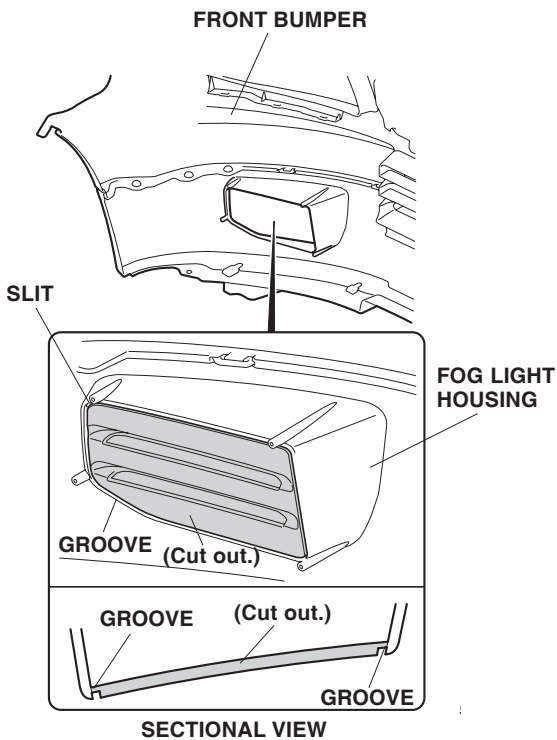

7. Install the grommet to the left sub-bracket. Install the left sub-bracket with one washer-bolt to the left fog light. The left sub-bracket is stamped with the identification mark "L", and the right sub-bracket is stamped "R".

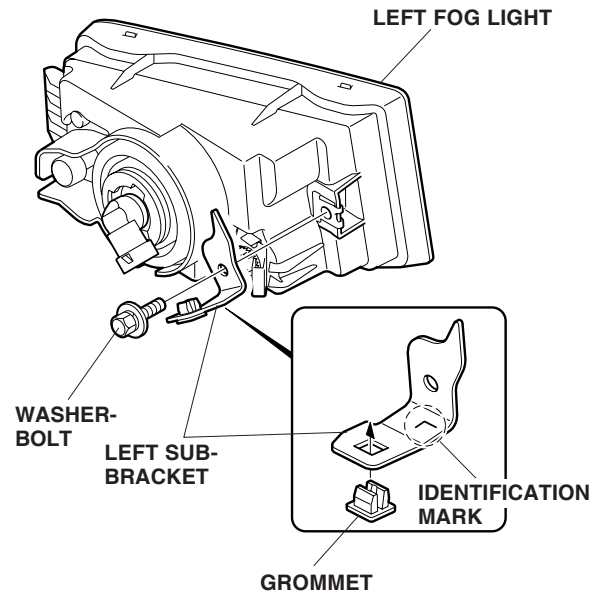

8. Inside the front bumper, slide the left fog light bracket into the cutout you made, and secure it with four self-tapping screws.

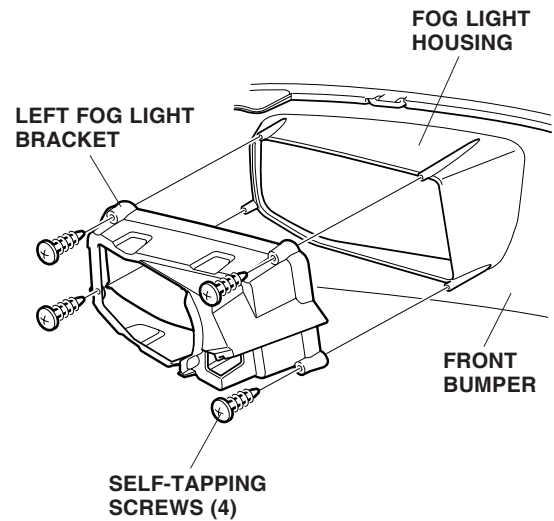

9. Insert the left fog light from the fog light opening at the front of the front bumper to the left fog light bracket and install it with one self-tapping washer-screw to the left fog light bracket.

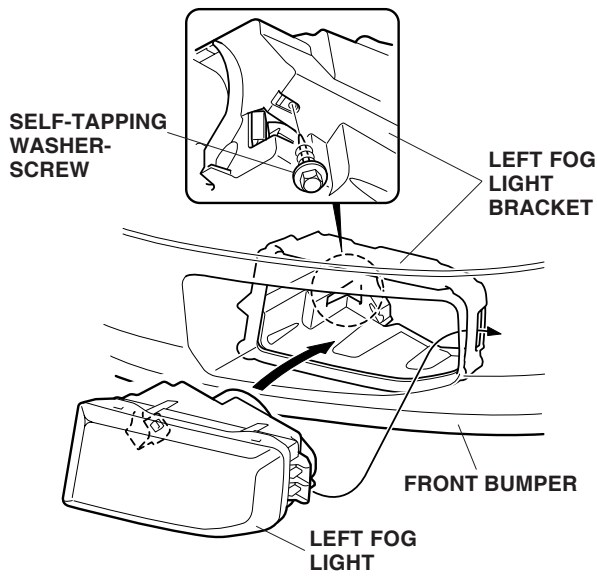

10. Repeat steps 5 thru 9 to cut the bumper and install the fog light on the right side.

Routing the Fog Light Harness

11. Starting under the left headlight, route the fog light harness 1-pin connector and ground terminal through the hole in the front bulkhead.

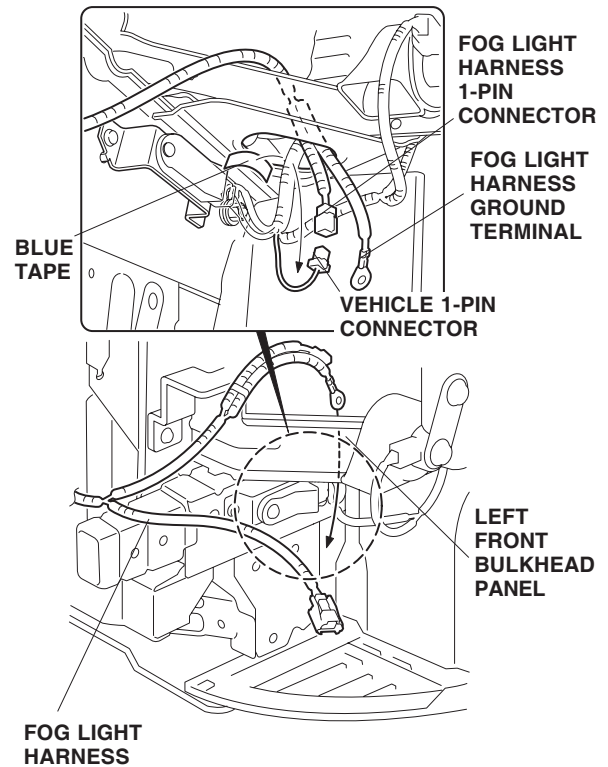

12. Locate the 1-pin connector blue-taped to the vehicle harness and remove the blue tape to free the 1-pin connector. Plug the 1-pin connector you just freed to the fog light harness 1-pin connector.

- Remove the ground bolt that fastens the vehicle ground terminal and secure the fog light harness ground terminal using the ground bolt.

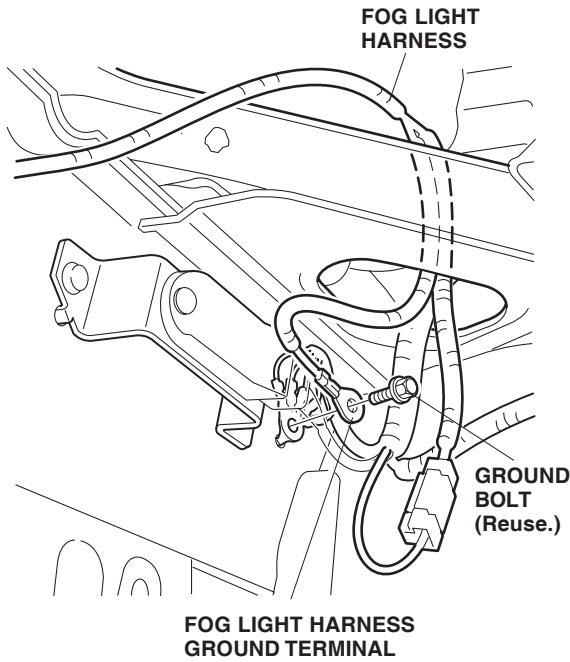

- Secure the fog light harness 1-pin connector and the fog light harness to the vehicle harness with one wire tie. Do not secure the 1-pin connector to the SRS harness with the wire tie.

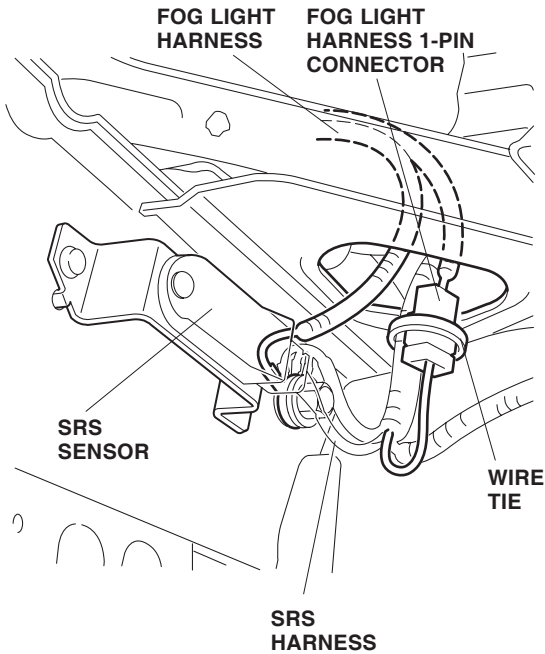

- Behind the front side frame, route the fog light harness 2-pin connector (short end) down, and out through the clearance between the side frame and front bumper beam.

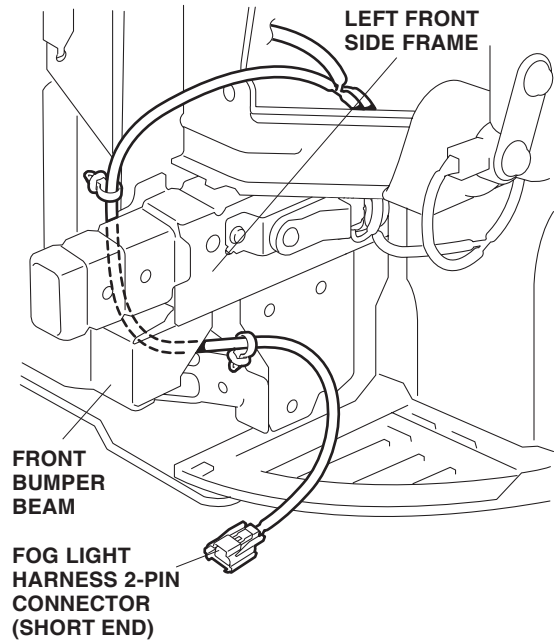

- Route the fog light harness 2-pin connector (long end) from underneath the left headlight to the engine compartment, then along the vehicle harness behind the front bulkhead upper frame.

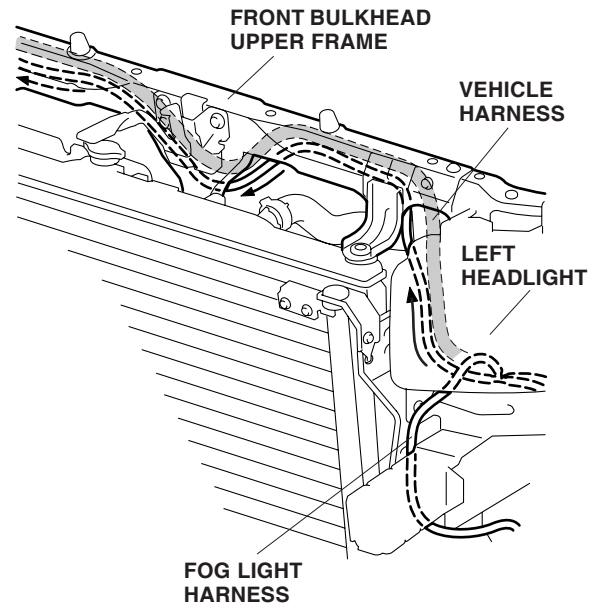

17. Continue routing the fog light harness 2-pin connector from underneath the right headlight to the front of the vehicle, then down to the bottom of the front side frame along the outside of the right bulkhead side stay.

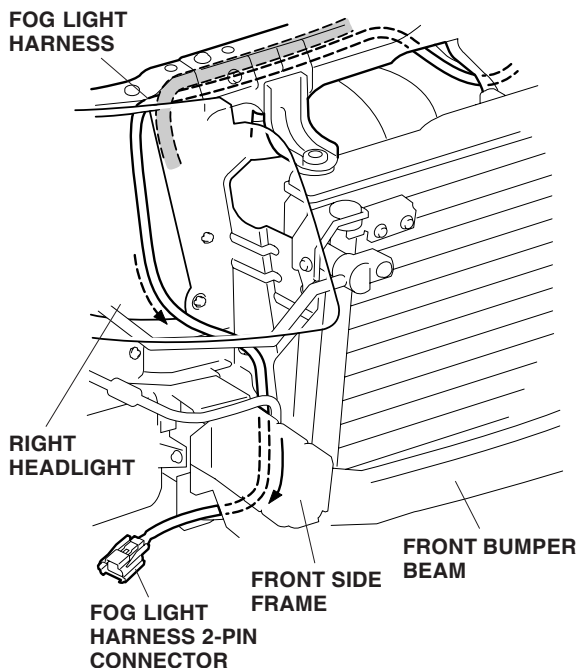

18. Push each of the two wire ties with clip on the fog light harness into the holes in the bulkhead side stay. Further secure the fog light harness to the vehicle harness with three wire ties in the areas shown.

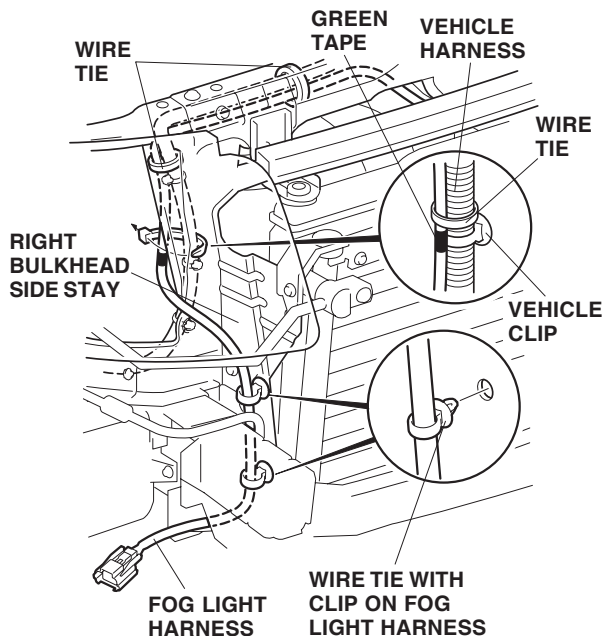

19. Secure the fog light harness to the vehicle harness with the eight wire ties in the areas shown.

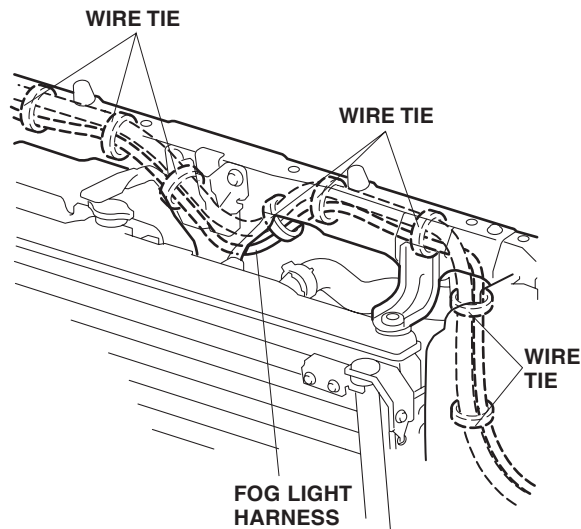

20. Secure the fog light harness.

Without Engine Block Heater:

- Secure the fog light harness to the holes in the bulkhead side stay and the left front bulkhead with the two wire ties with clip.
- Secure the fog light harness to the vehicle harness with one wire tie.
- Push each of the two wire ties with clip on the fog light harness into the holes under the front side frame and the bulkhead side stay.

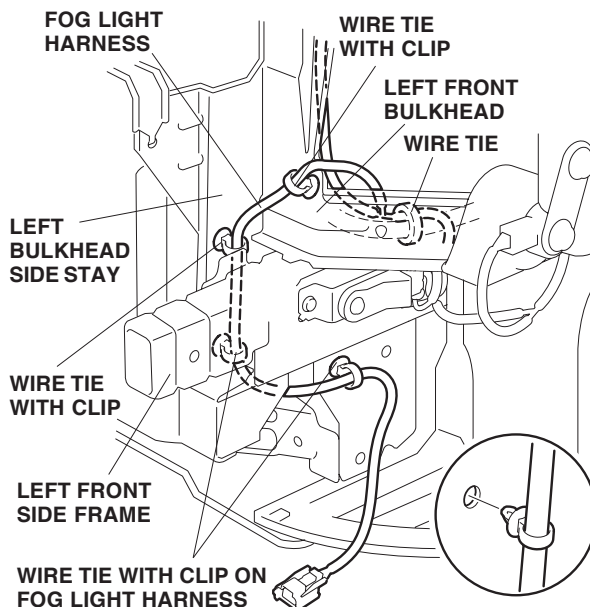

With Engine Block Heater:

- Secure the engine block heater and fog light harnesses to the bulkhead side stay and front bulkhead with the two wire ties on the engine block heater harness and two wire ties with clip.
- Secure the fog light harness to the vehicle harness with one wire tie.
- Push each of the two wire ties with clip on the fog light harness into the holes under the front side frame and the bulkhead side stay.

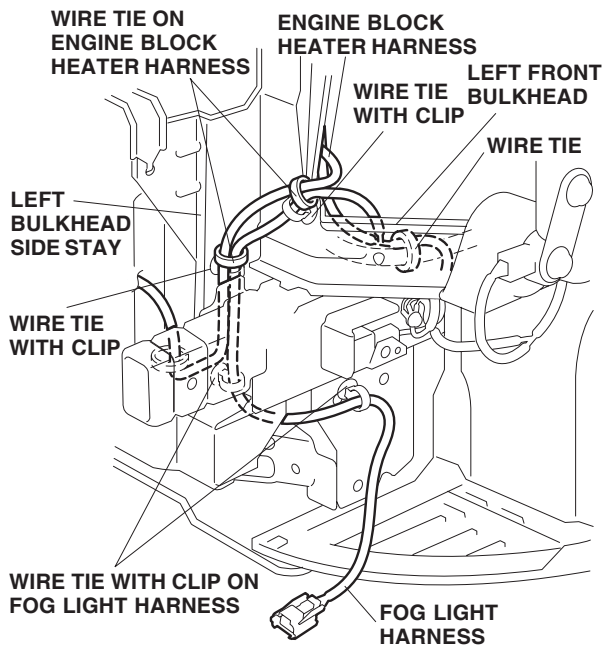

21. Using the utility knife, cut out the marked area from the left front inner fender along the scribed line on the back. Remove any burrs from the edge with a file.

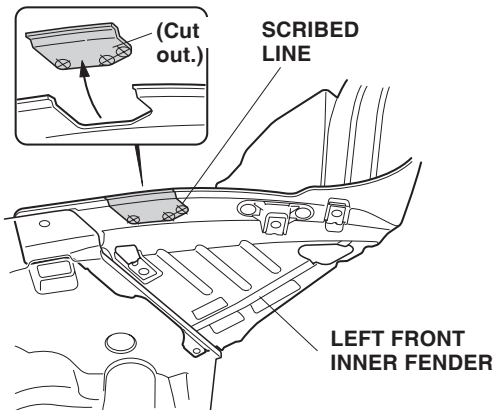

22. Cut the right front inner fender the same way.

23. While holding the front bumper near the front of the vehicle, plug the fog light harness 2-pin connectors into the 2-pin connectors from the fog lights. Reinstall the front bumper.

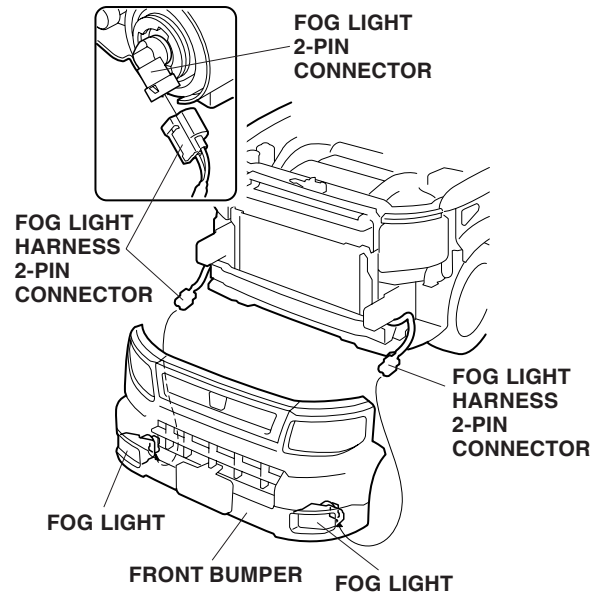

Routing the Switch Harness

24. Remove the driver's dashboard lower cover, turn the knobs clockwise, then pull the cover out toward you to release the six retaining tabs.

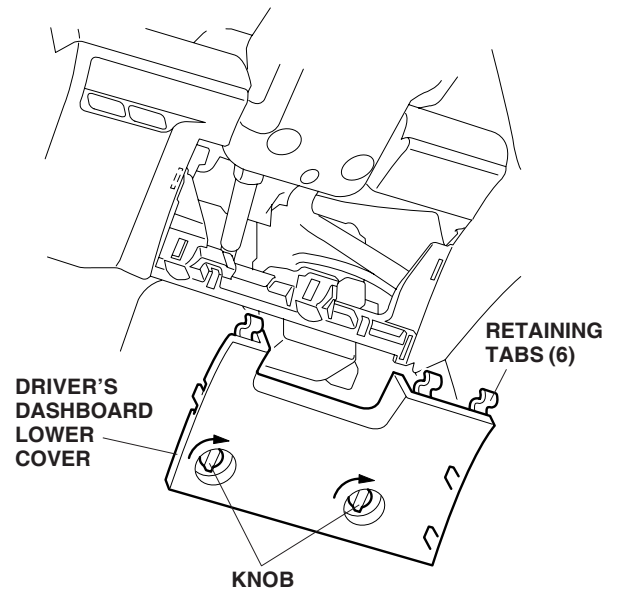

25. Lower the steering wheel using the tilt lever. Remove the two self-tapping screws and one washer-screw from the lower steering column cover.

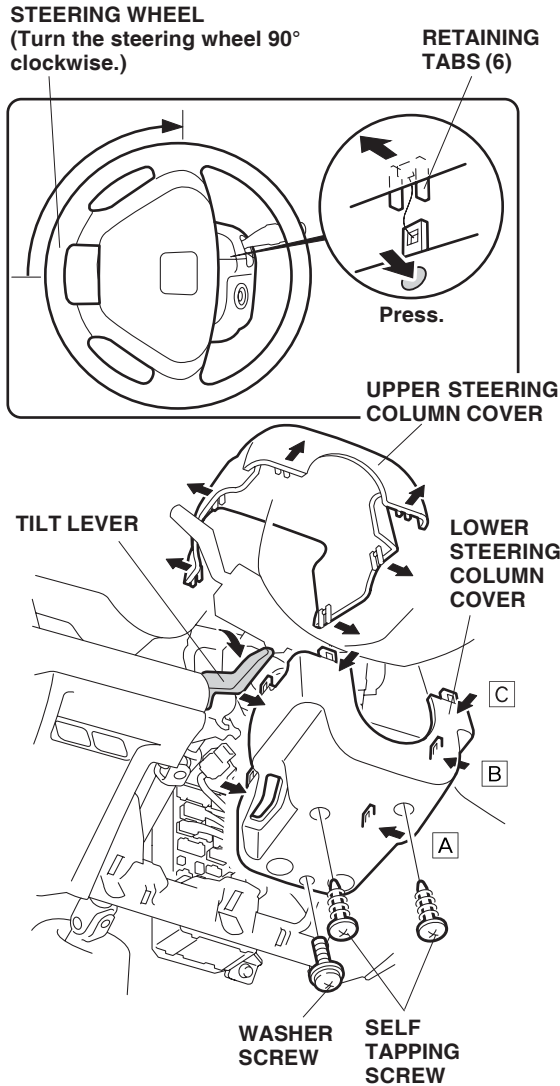

26. Separate the upper steering column cover from the lower steering column cover.
- Turn the steering wheel 90° clockwise, and press point **A** to release the retaining tab.
 - Press point **B** and then **C** to release the retaining tabs. Once these retaining tabs are released, the retaining tabs on the opposite side will release.

27. Slide the relay bracket onto the switch harness relay block

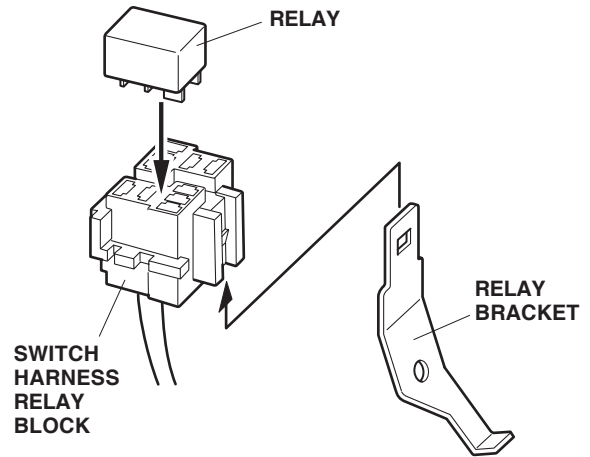

28. Insert the relay bracket onto the switch harness relay block.
29. Install the relay bracket on the data link connector bracket using one washer-bolt and flange nut.

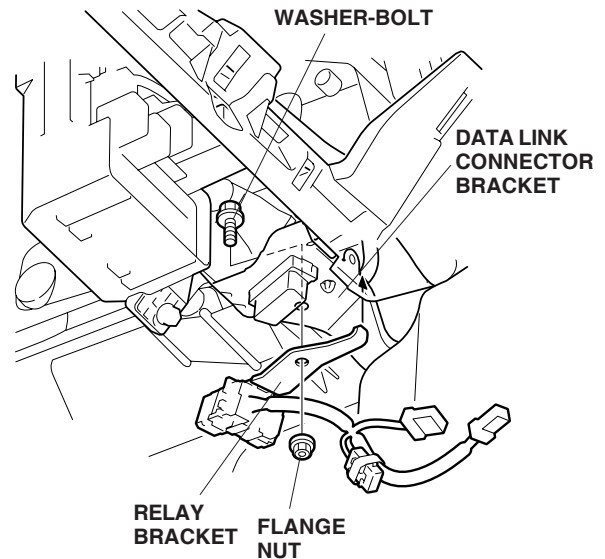

30. Locate the 3-pin connector blue-taped to the vehicle harness and remove the blue tape to free the 3-pin connector. Slide the clip onto the 3-pin connector you just freed.

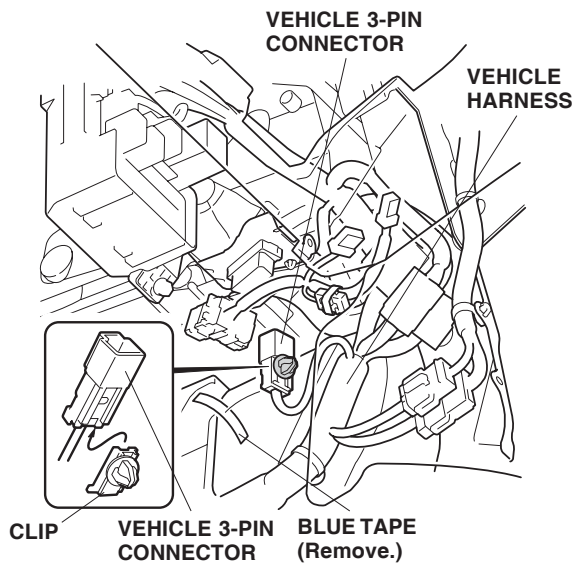

31. Attach the 20A fuse label to the switch harness fuse case.

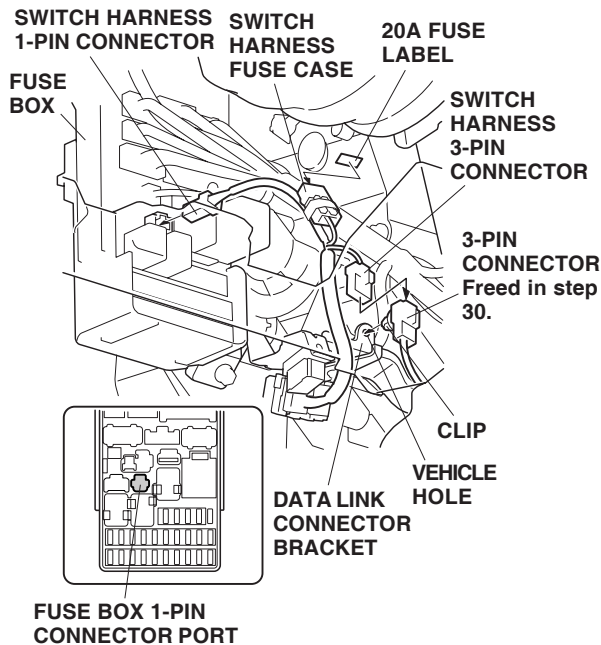

32. Plug the switch harness 1-pin connector into the fuse box in the location shown.
33. Plug the switch harness 3-pin connector into the 3-pin connector freed in step 30. Push the connector clip into the vehicle hole shown.

34. Secure the switch harness to the vehicle harness with two wire ties.

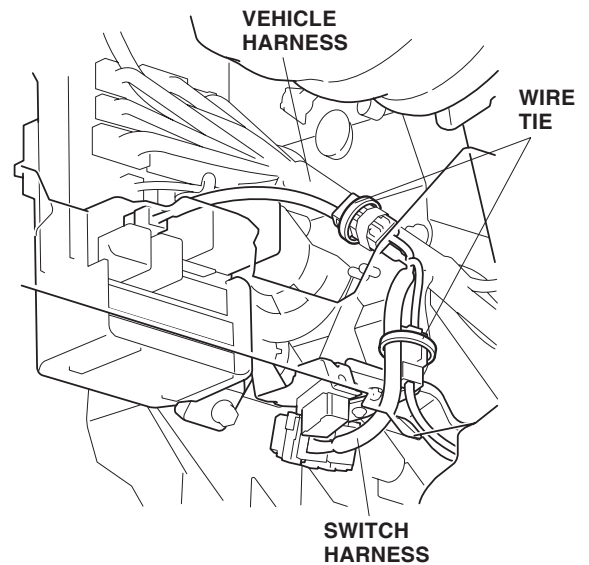

35. Turn the steering wheel 90° counterclockwise.

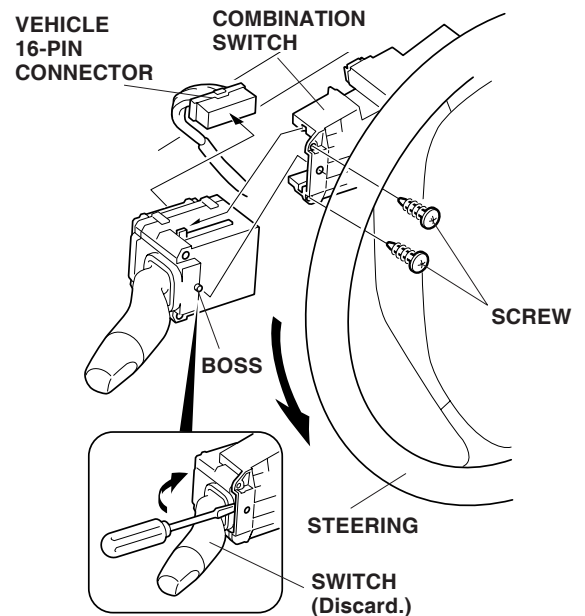

36. Unplug the vehicle 16-pin connector from the switch. Remove the two screws from the switch.
37. Pry off the boss by inserting the end of a flat-tip screwdriver between the combination switch and switch, then moving in the direction shown while holding the switch from the combination switch.
- Hold the case and not the lever to remove the switch from the combination switch.

38. Install the new switch and plug the vehicle 16-pin connector to the new switch.
 - Make sure you hold the case when installing the switch.

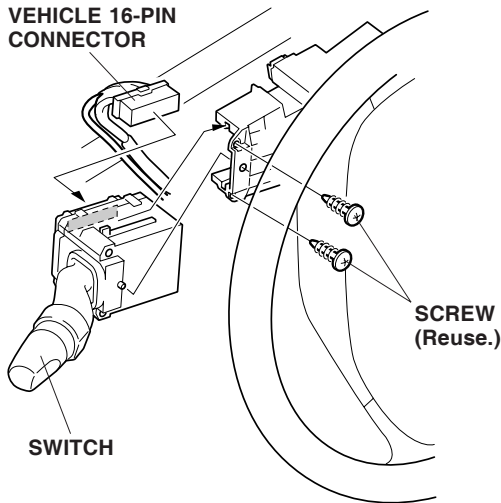

39. Check that all wire harnesses are routed properly and all connectors are plugged in.
40. Reinstall all removed parts. Check that all clips and fasteners are installed securely.
41. Reconnect the negative cable to the battery.
42. Reset the clock, and reset the radio station presets.

NOTE: When the battery is disconnected, the driver's window AUTO function is disabled.

43. Start the engine. Push down on the driver's window switch until the window is fully open.
44. Pull up on the driver's window switch fully to close the window completely, then hold the switch for 2 seconds or more.
45. Test the window AUTO function.

USE AND CARE

How to Operate Fog Lights

- Turn the light switch to the "D" position (headlights on low beam).
- Turn the fog light switch (indicator "F" in the meter come on).

NOTE: The fog light lenses can cloud when the outside temperature is cold; this is normal and should go away in warm weather.

- If the fog light don't come on, check the fuse and all the connectors, including the ground cable.

Fog Light Aiming Adjustment

- Adjust the aiming according local laws and regulations.
- To adjust, turn the aiming adjustment gear in or out until the correct aiming is obtained.

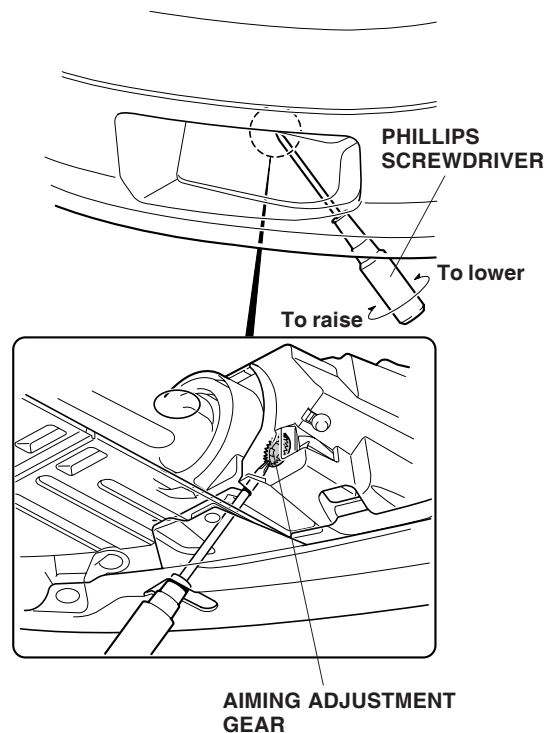

Replacing the Fog Light Bulb

1. Remove the self-tapping washer-screw from the fog light, pull out the fog light, and disconnect the connector.

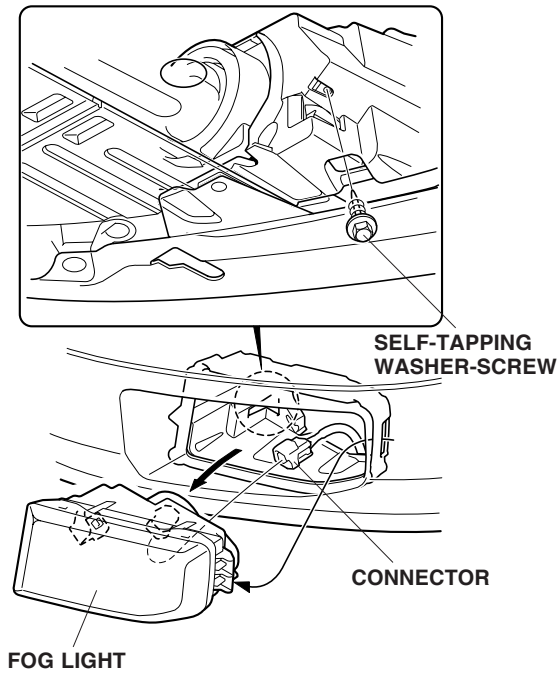

2. Turn the bulb 45° counterclockwise and remove it from the socket.

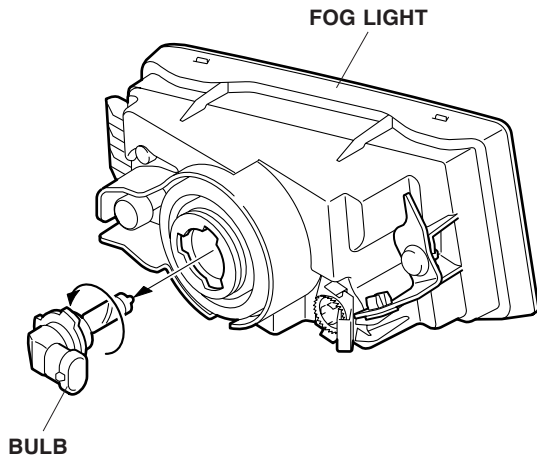

3. Install the new bulb into the socket.

- Use only a genuine Honda halogen light bulb of specified wattage.

Rating: 12V 51W HB4 Halogen Light Bulb
P/N 33104-S3V-A010-M1

- Do not touch the bulb. Oily or greasy substances on the bulb can shorten its service life due to the heat produced when the bulb is turned on. If the bulb is accidentally touched, wipe it clean with a soft cloth that has been dampened with denatured alcohol or a mild detergent solution.
- Align the tab on the fog light with the cutout in the bulb when installing the new bulb. If not aligned, the fog light may annoy oncoming drivers.

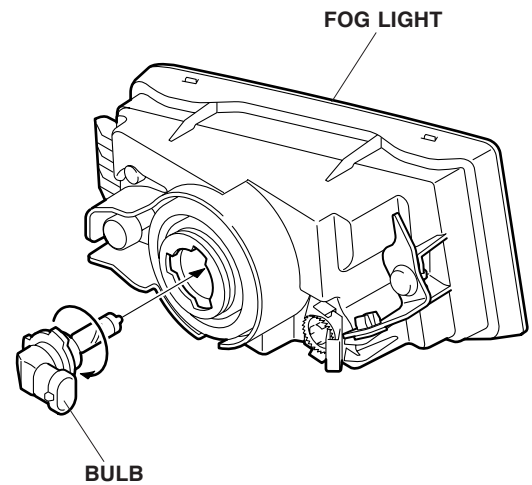

4. Reinstall the removed parts in the reverse order of removal.

- Check that the wire harnesses are not pinched.
- Make sure to tighten the screws securely.

5. Check the operation of the fog light; adjust the aiming if necessary.

CIRCUIT DIAGRAM

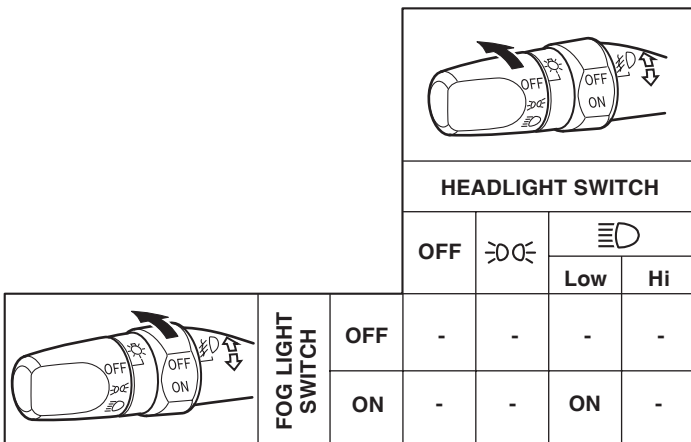
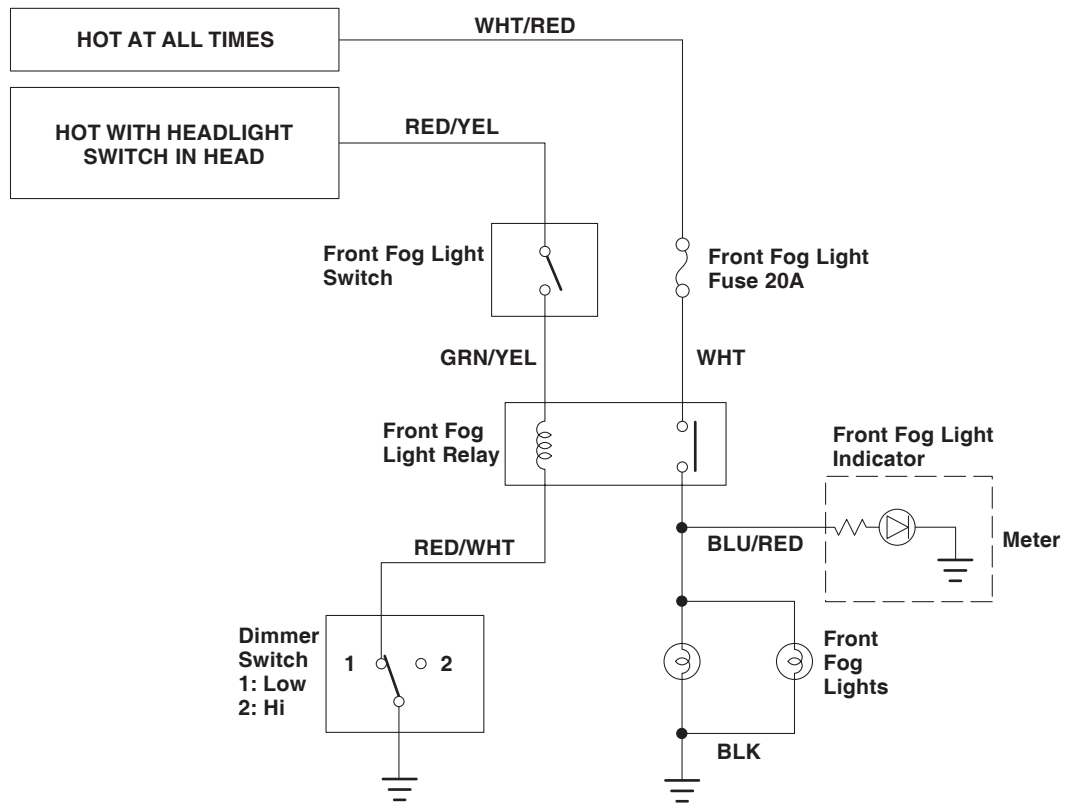

BLK	BLACK	BRN	BROWN
YEL	YELLOW	ORN	ORANGE
BLU	BLUE	PUR	PURPLE
GRN	GREEN	NAT	NATURAL
RED	RED	PNK	PINK
WHT	WHITE	GRY	GRAY
LT BLU	LIGHT BLUE	LT GRN	LIGHT GREEN

6224040K