



# INSTALLATION INSTRUCTIONS

Accessory  
**TRUNK SPOILER (LOW)**

Application  
**2007 CIVIC  
4-DOOR**

Publications No.  
**All 33497**  
Issue Date  
**AUG 2006**

## PARTS LIST

Trunk spoiler

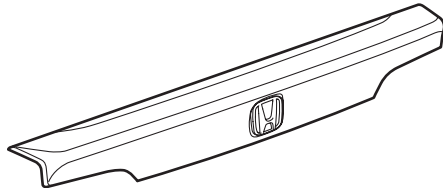

Right trunk spring (marked red)

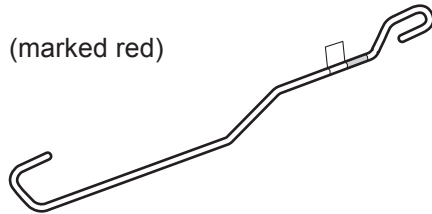

Left trunk spring (marked yellow)



Template

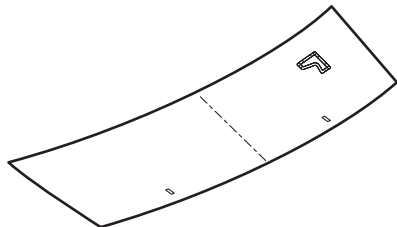

2 Flange nuts



2 Protective tapes

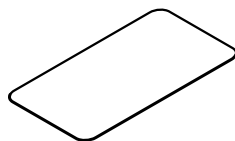

## TOOLS AND SUPPLIES REQUIRED

Eye protection (face shield, safety goggles, etc.)

Drill

3 mm and 8 mm Drill bits

File

Center punch

Touch-up paint

Ratchet

10 mm Socket

Torque wrench

Masking tape

Felt-tip pen

Shop towel

Isopropyl alcohol

Trunk Spring Installation/Removal Tool:

T/N 07XAZ-S0K-0100 or 07AAF-SNA-A100

## INSTALLATION

**Customer Information:** The information in this installation instruction is intended for use only by skilled technicians who have the proper tools, equipment, and training to correctly and safely add equipment to your vehicle. These procedures should not be attempted by "do-it-yourselfers."

### NOTE:

- Using isopropyl alcohol, thoroughly clean the area where the trunk spoiler will be attached. Use a shop towel to apply the cleaner, and wipe up spilled cleaner at once. Allow the cleaner to dry thoroughly before installing the trunk spoiler.
- Be careful not to damage the body paint finish.
- This trunk spoiler kit should be installed only if the ambient air temperature is 60°F (15°C) or above.
- To allow the adhesive to "cure," do not wash the vehicle for 24 hours.

## INSTALLATION

1. Open the trunk lid. If equipped, remove the hinge arm cover (two clips).

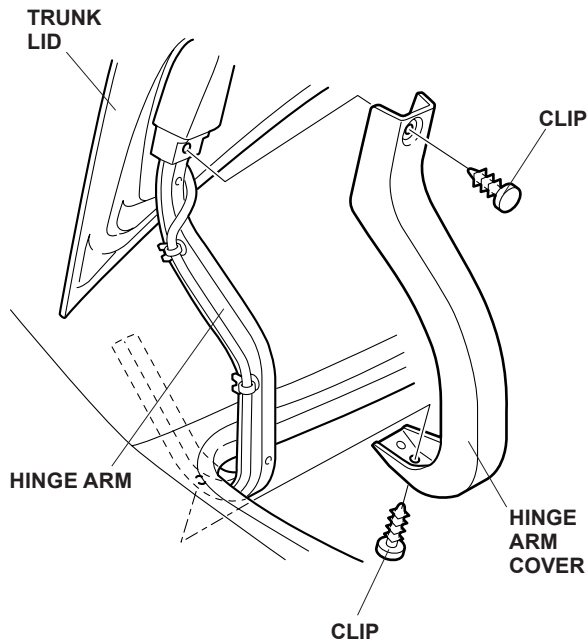

2. If equipped, remove the trunk liner (four clips and four long clips).

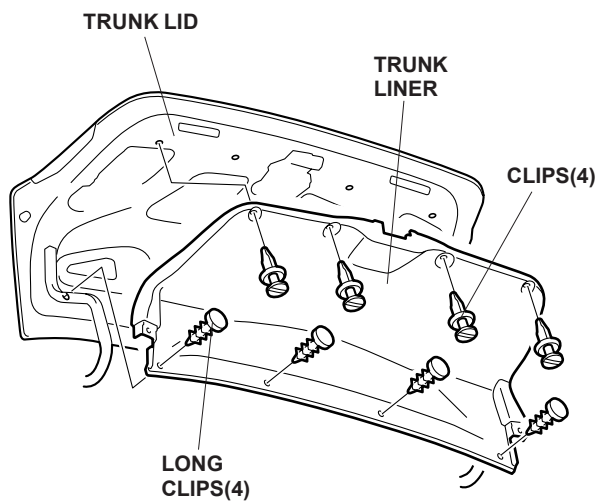

## Installing the Trunk Springs

3. Open the trunk lid, and remove the center clip from the trunk springs.

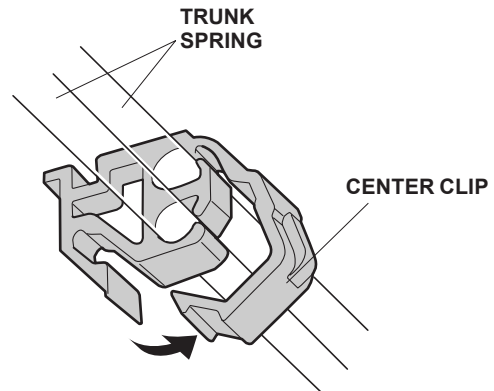

4. With an assistant holding the trunk lid open, remove the old trunk springs from the trunk hinge arms using the special tool. Wear gloves to protect your hands, and pull the special tool slowly and carefully toward you.

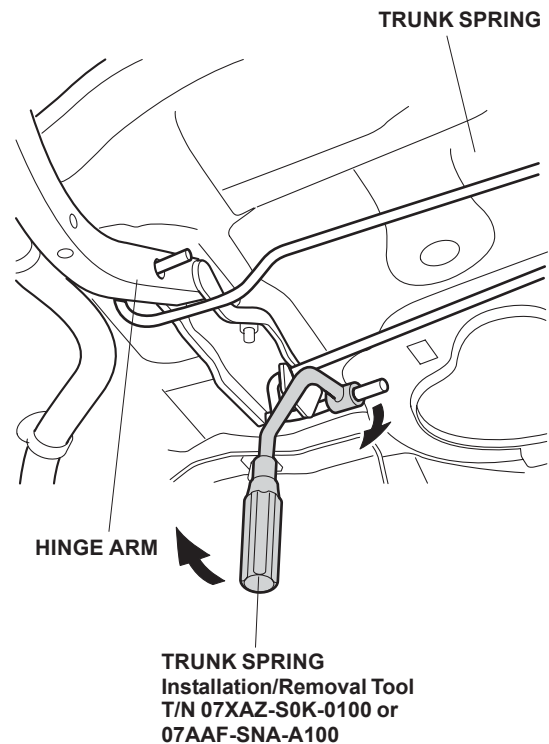

5. Using the trunk spring installation/removal tool, install the right trunk spring and the left trunk spring:
  - Set the tool on the marked end of each trunk spring.
  - Install the red marked spring in the slot in the right (passenger's) side trunk hinge arm and into the hinge bracket on the left (driver's) side of the vehicle; install the yellow-marked spring in the slot in the left (driver's) side trunk hinge arm and into the hinge bracket on the right (passenger's) side of the vehicle.
  - Wearing gloves, rotate the tool as you pull it toward you.
  - Set the springs in the first notch of the hinge brackets if the vehicle is not equipped with a trunk liner: set the springs in the second notch of the trunk liner if the vehicle is equipped with a trunk liner.

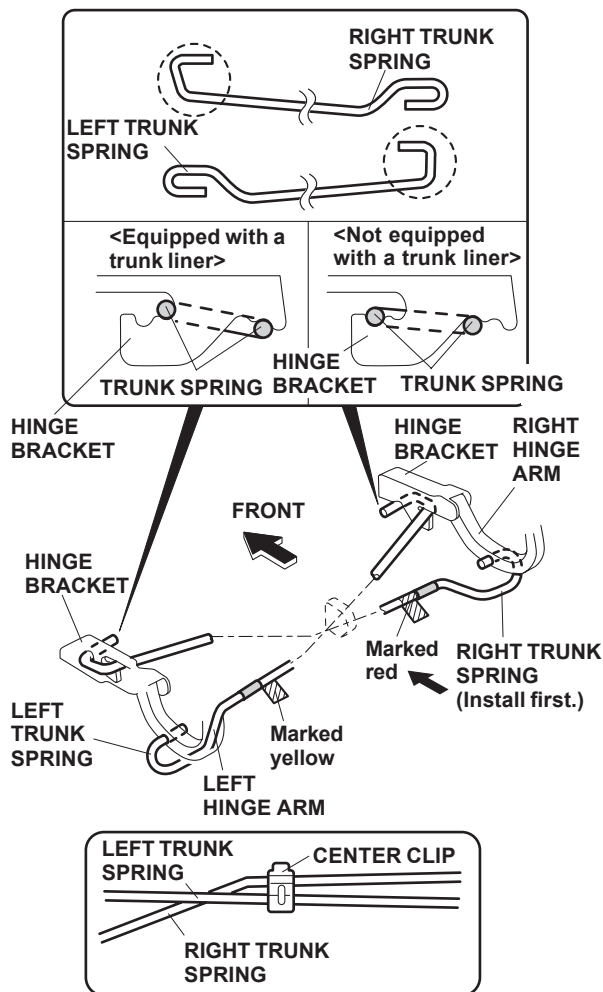

6. Reinstall the center clip on the trunk springs.

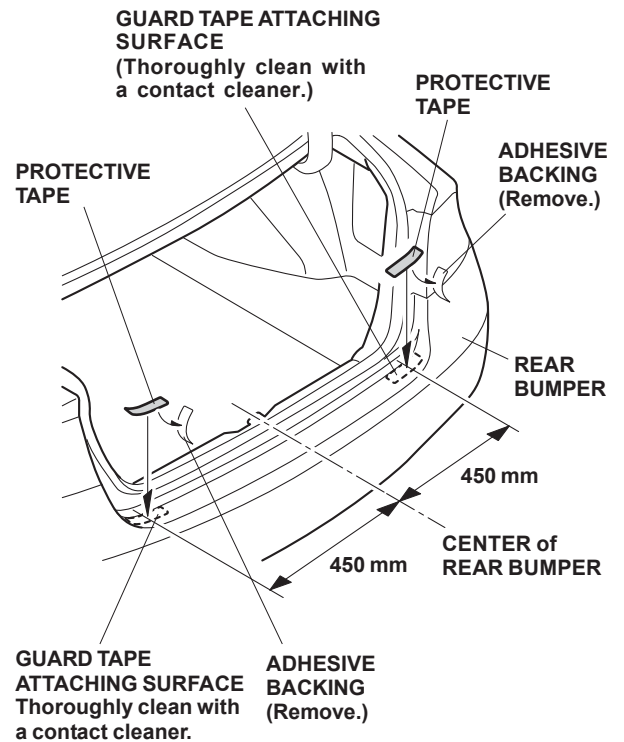

7. Remove the adhesive backing from each of the protective tapes, and attach the tapes to the rear bumper as shown.

**NOTE:** The protective tapes are designed to protect the rear bumper from being hit by the trunk lid when it is closed. Be sure to attach the tapes in the specified positions securely.

- Close the trunk lid. Remove the rear "H" emblem from the trunk lid by cutting the outer edges with a piece of string. If the clips remain attached to the rear "H" emblem, remove and reinstall the clips in their original positions on the trunk lid. Set the emblem aside; it will not be reused.

Move the string in the direction shown.

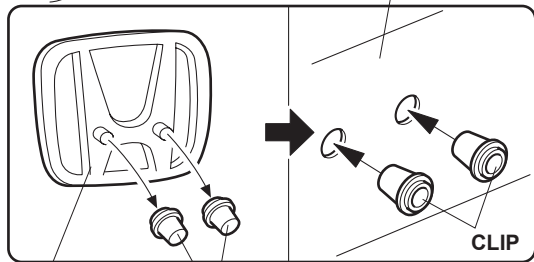
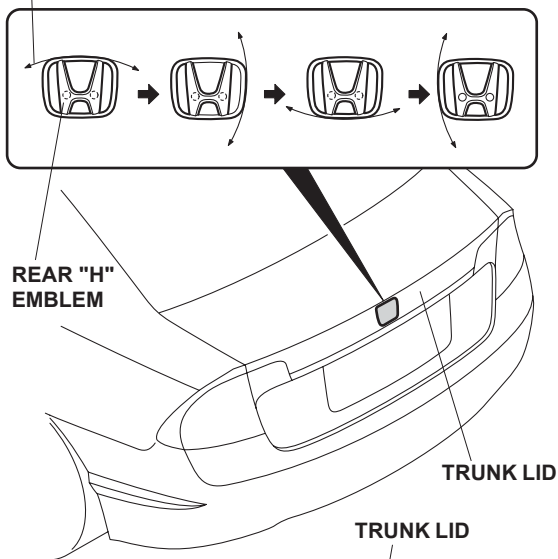

- Using scissors, cut the small template A out of the template.

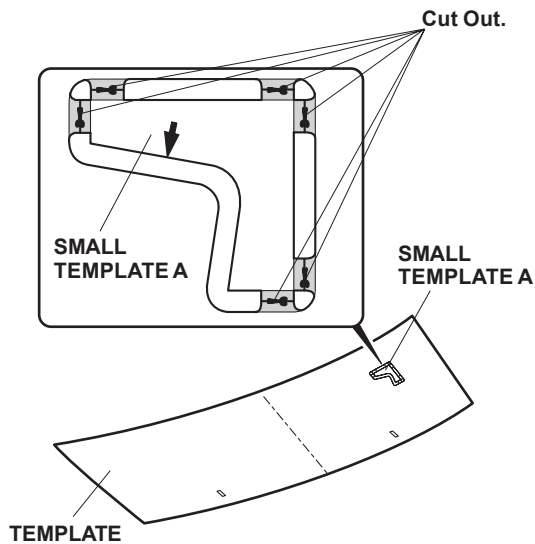

- Align the front edge of the template with the front edge of the trunk lid. Center the template from side to side. Secure the template with tape. Using a felt-tip pen, mark the two places on the trunk lid. Remove the template.

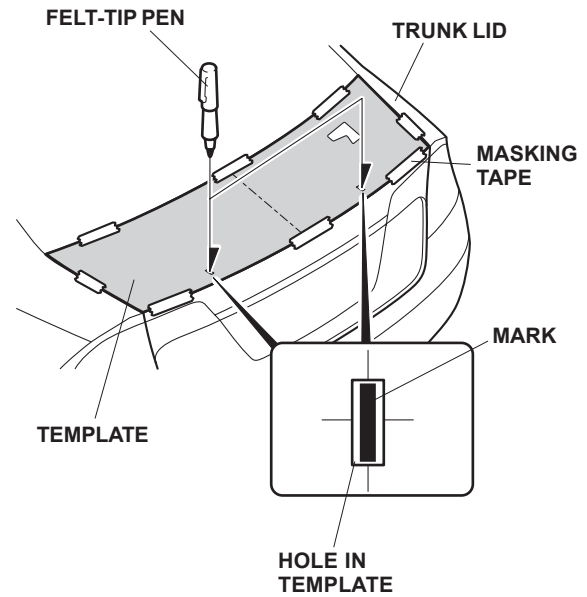

- Position the template A on the trunk lid. Using a felt-tip pen, mark the trunk lid on the left and right sides.

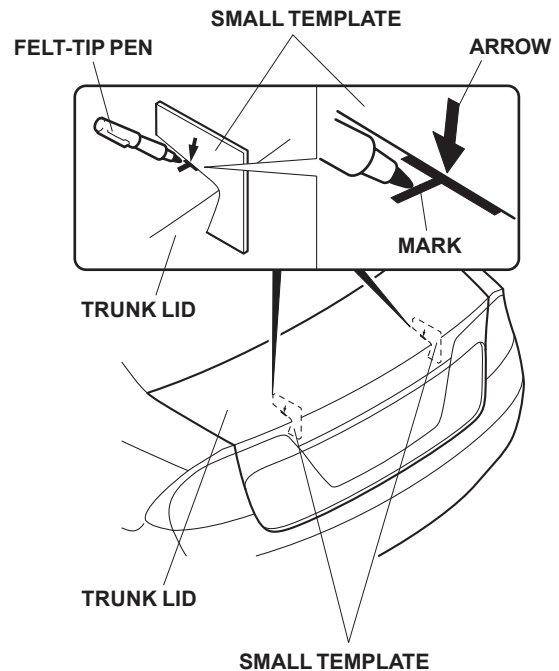

12. Center-punch each mark.

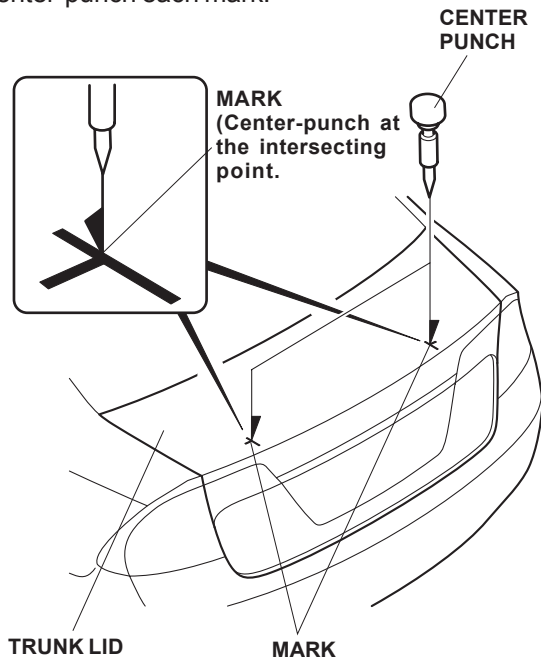

13. While wearing eye protection, drill two 8 mm holes through the marks as shown.

- To prevent the metal shavings from falling onto the trunk floor, place a drop cloth inside the trunk.
- Using a drill stop on the end of each bit, first drill with a 3 mm drill bit, and finish with an 8 mm drill bit. Take care not to damage the wire harnesses when drilling.
- After drilling, remove any burrs from the edges of the holes with a file and apply touch-up paint on both sides of the holes. Allow the touch-up paint to dry thoroughly before proceeding to the next step.

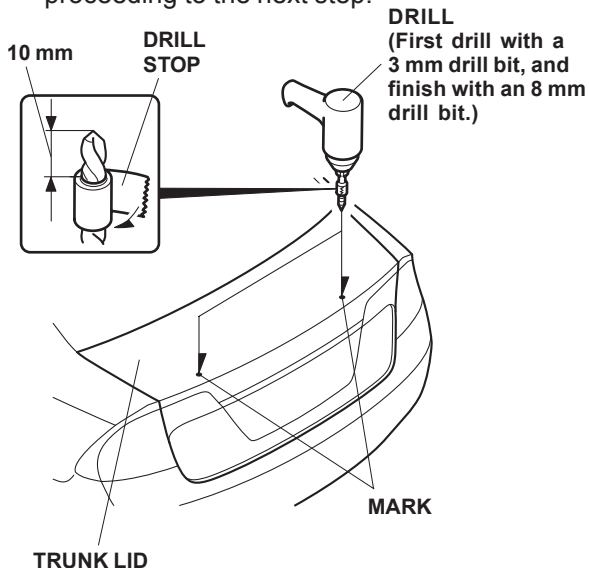

14. On the inside of the trunk spoiler, attach a strip of masking tape to the ends of the adhesive backings, and peel back 1 to 2 inches of the adhesive backing. Fold the ends back, and tape them to the front of the spoiler.

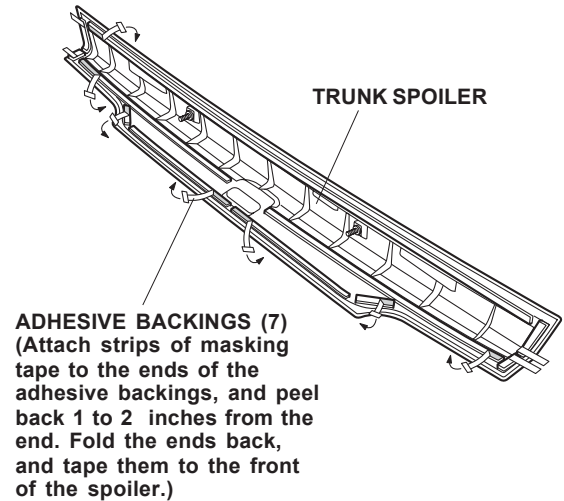

15. Using isopropyl alcohol on a shop towel, thoroughly clean the area where the trunk spoiler will attach.

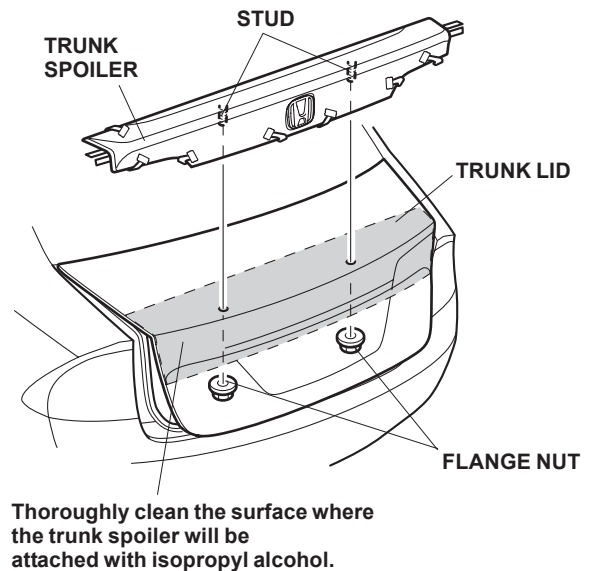

16. Fit the spoiler into position on the trunk lid by inserting the two studs into the holes in the trunk lid. With an assistant holding the trunk lid open, install a flange nut on the end of each stud, but do not tighten them yet.

- Adjust the width from the end of the trunk spoiler to the end of the trunk lid so that it is equal on the right and left sides. Carefully remove the adhesive backings in the order shown.

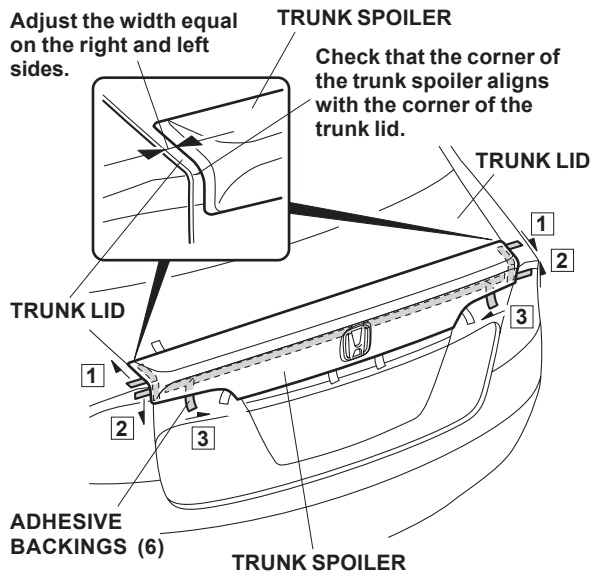

- Check that the corner of the trunk spoiler aligns with the corner of the trunk lid. Press the trunk spoiler against the trunk lid firmly with your fingers.
- Remove the adhesive backings in the order shown. Hold the spoiler firmly against the trunk lid with the palm of your hand.

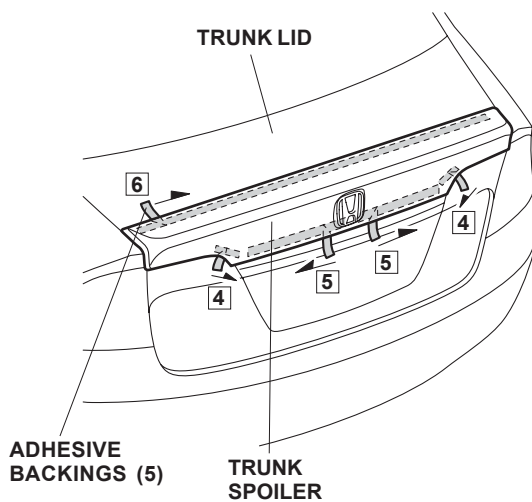

- Torque the two flange nuts to 10 N·m (6.7 lb-ft).
- Apply pressure to the trunk spoiler to secure the adhesive tapes.
  - When the workshop room temperature is below 60°F (15°C), warm up the trunk spoiler to 60°F (15°C) or above before attaching it to the vehicle body.
  - Neglecting to warm up the trunk spoiler can cause the trunk spoiler to fall off.
- Open the trunk lid, and make sure the trunk lid stays open on its own. If it does not, adjust the trunk springs to the second position.
- Reinstall all removed parts.

### USE AND CARE

- Handle the spoiler with care. It is not designed to absorb impact.
- Do not open or close the trunk lid by grasping the spoiler.
- Check the spoiler mounting nuts periodically, and retighten them if necessary.