



# INSTALLATION INSTRUCTIONS

Accessory

**FRONT UNDER SPOILER**  
P/N 08F01-SVA-101

Application

**2007 CIVIC**  
**2-DOOR**

Publications No.

**All 33534-33774**

Issue Date

**SEP 2007**

## PARTS LIST

Front under spoiler

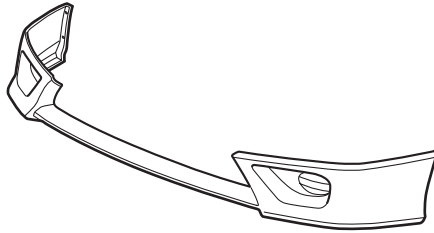

7 Flange bolts



7 Flange nuts



4 Self-tapping screws



4 Spring nuts



Spacer

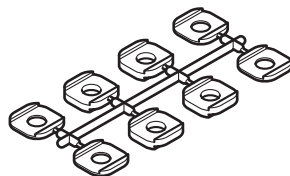

## TOOLS REQUIRED

Phillips screwdriver

Flat-tip screwdriver

Drill

3 mm and 10 mm Drill bits

Clip remover

Pushpin

Blanket

Masking tape

Isopropyl alcohol

Shop towel

Eye protection

## INSTALLATION

**Customer Information:** The information in this installation instruction is intended for use only by skilled technicians who have the proper tools, equipment, and training to correctly and safely add equipment to your vehicle. These procedures should not be attempted by "do-it-yourselfers."

### NOTE:

- Using isopropyl alcohol on a shop towel, thoroughly clean the area where the front under spoiler will be attached.
- Be careful not to damage the front bumper and body paint finish.
- This front under spoiler kit should be installed only if the ambient air temperature is 60°F (15°C) or above.
- To allow the adhesive to "cure", do not wash the vehicle for 24 hours.

1. Remove the front bulkhead cover (two expansion clips, three clips and move the right and left fender trims inward).

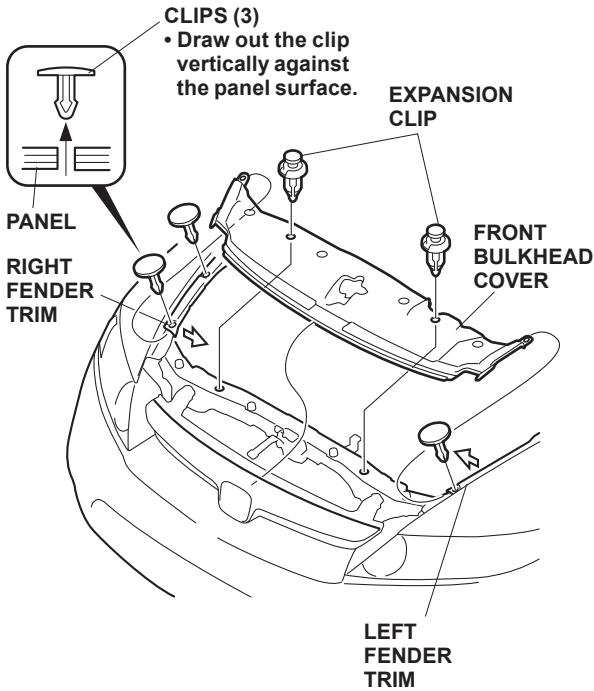

2. Remove the front bumper (two bolts, ten clips, and two self-tapping screws and pull the bumper out towards you). If equipped, unplug the fog light connectors. If equipped, unplug the front corner sensor connectors. Place the front bumper on a blanket to install the front under spoiler.

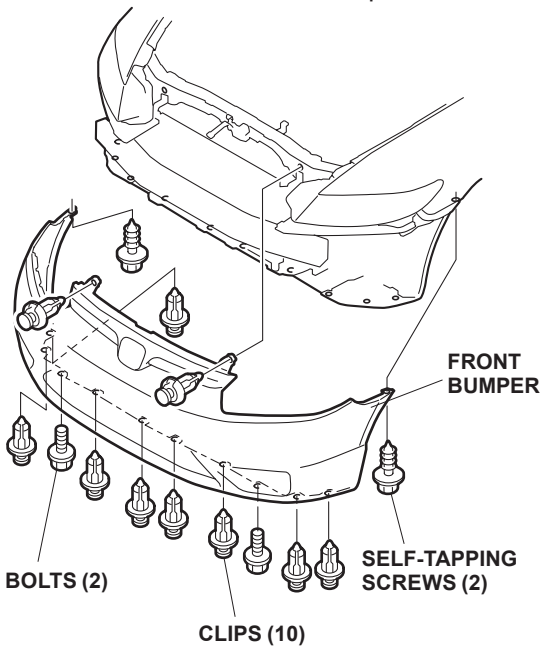

3. Inside the bumper, locate the center of the scribe marks, and make a hole through each mark with a pushpin.

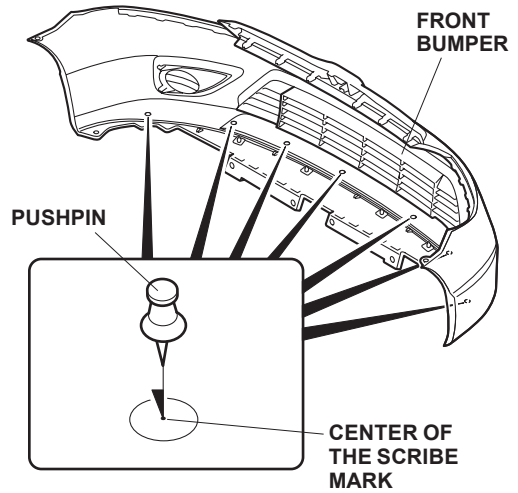

4. Using a drill, drill a 10 mm hole through each marked location from the front of the bumper. First drill with a 3 mm bit, and finish with a 10 mm bit. Remove any burrs from the edges of the holes with a file.

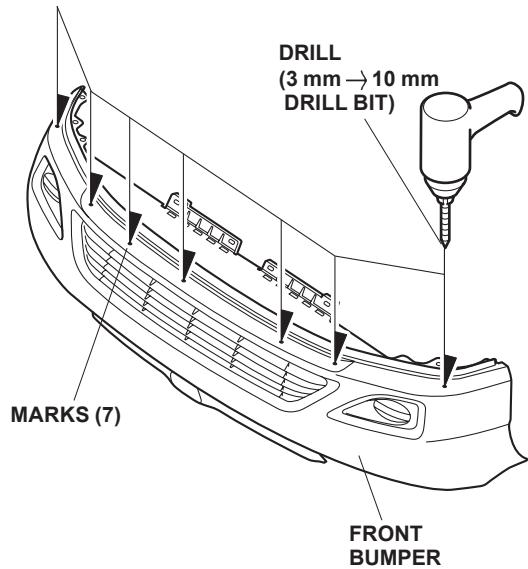

5. Using a drill, drill a 3 mm hole through four dimpled areas of the front bumper on both sides. Remove any burrs from the edges of the holes with a file.

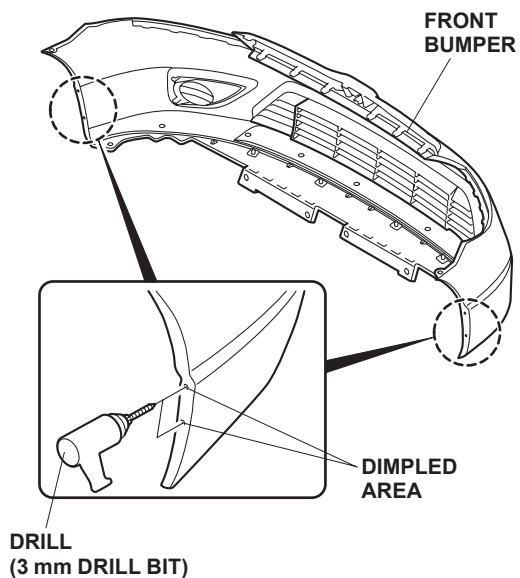

6. Slide a spring nut over each of the four holes you made in the front bumper.

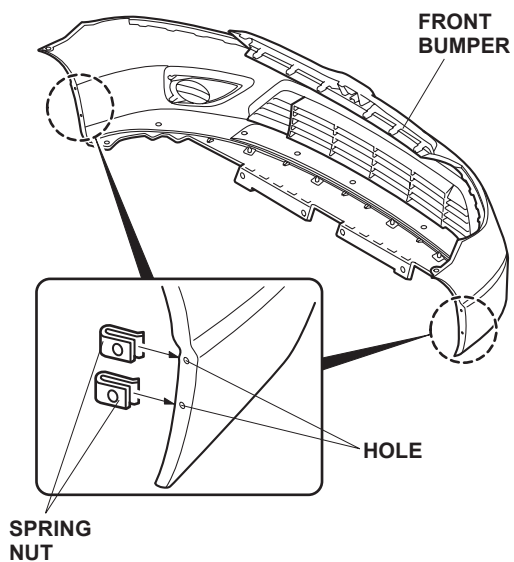

7. Attach a strip of masking tape to the end of each adhesive backing, and peel back 1-1/2 to 2 inches of the adhesive backing. Fold the ends back, and tape them to the front of the front under spoiler.

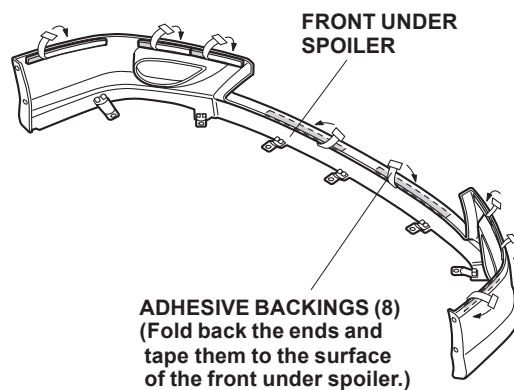

- Using isopropyl alcohol on a shop towel, clean the front bumper where the front under spoiler will attach.

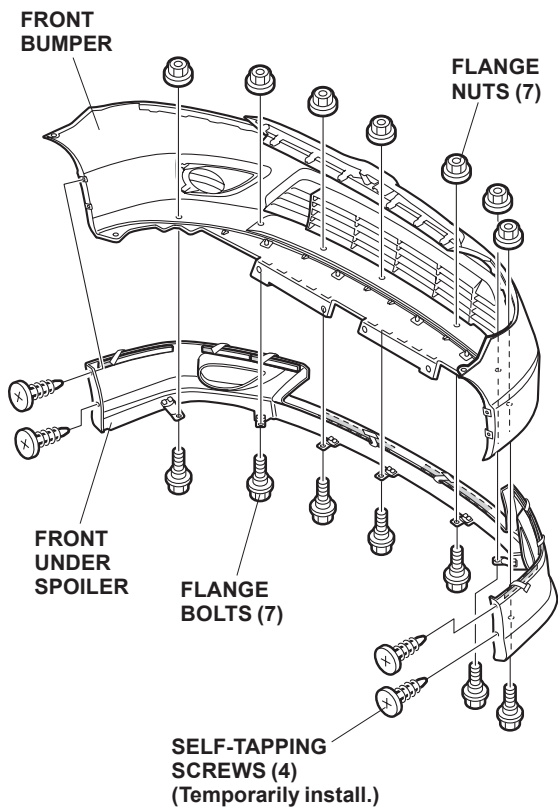

- Position the front under spoiler on the front bumper, and temporarily install the four self-tapping screws.
- Secure the front under spoiler to the front bumper with a flange-nut to each flange bolt.
- Reinstall the front bumper.

- While holding pressure on the front under spoiler, carefully remove the adhesive backings in the sequence shown. After removing, hold the front under spoiler firmly against the front bumper with the palm of your hand for 30 seconds. If the adhesive backing is difficult to remove; while applying pressure on the front bumper, remove the adhesive backings.

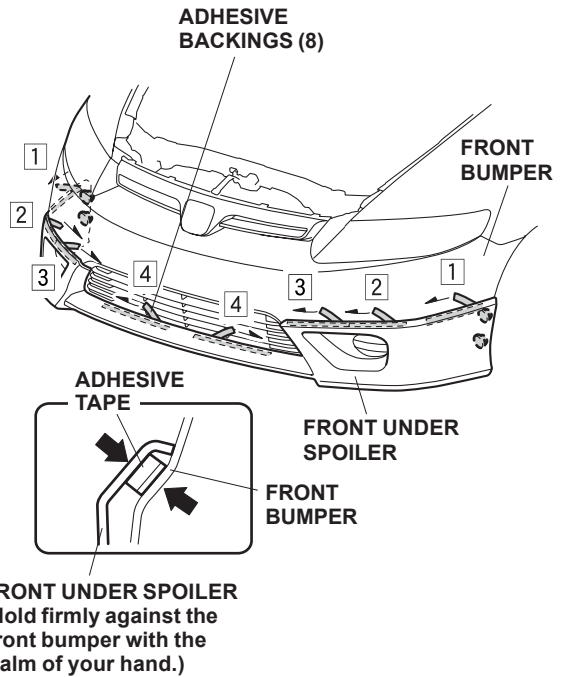

13. Tighten the self-tapping screws temporarily installed in step 9. If there is a gap, use one (or two) spacer(s) between the front bumper and the front under spoiler to prevent excess gaps as shown.

- If there is a gap, use a 1 mm spacer or a 2 mm spacer as shown.
- Do not use two spacers on one self tapping screw.
- Using diagonal cutters, cut one end of the spacer to install through the self tapping screw.

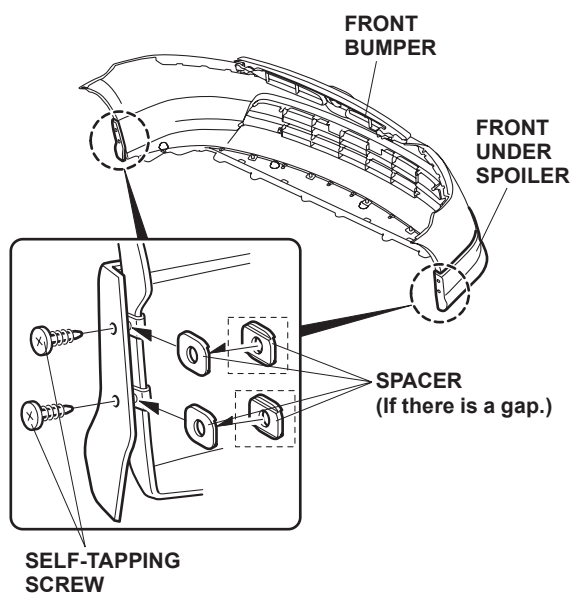

14. Reinstall all removed parts.