

HONDA
INSTALLATION
INSTRUCTIONS

Accessory
FOG LIGHTS
 P/N 08V31-SWA-100

Application
2007 CR-V

Publications No.
All 32952
 Issue Date
SEP 2006

PARTS LIST

Right fog light

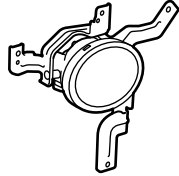

Left fog light

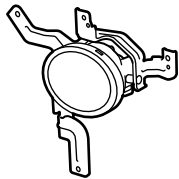

Fog light harness

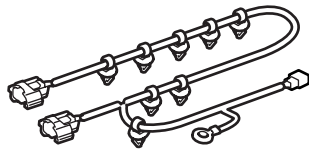

Fog light switch harness

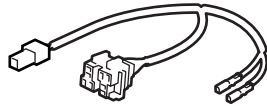

Right trim



Left trim



Switch

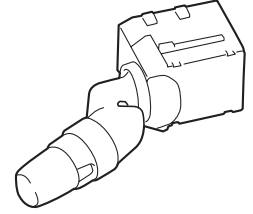

Relay

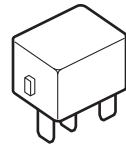

Bracket

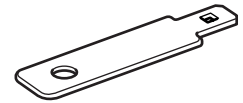

15 Wire ties

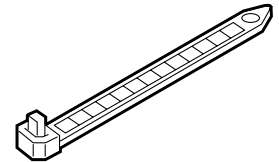

4 Wire tie with clips

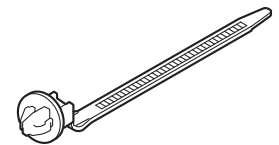

2 Adhesive tapes

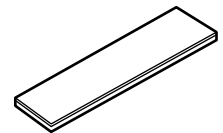

8 Self-tapping screws, 5 x 16 mm



Washer bolt, 6 x 16 mm

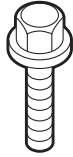

Flange nut, 6 mm



Fuse (20A)

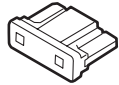

TOOLS AND SUPPLIES REQUIRED

- #2 Phillips screwdriver
- Flat-tip screwdriver
- Diagonal cutters
- Ratchet
- 10 mm Socket
- 10 mm Combination wrenches
- Hook tool
- Isopropyl alcohol
- Utility knife
- Masking tape

Illustration of the Fog Lights Installed on the Vehicle

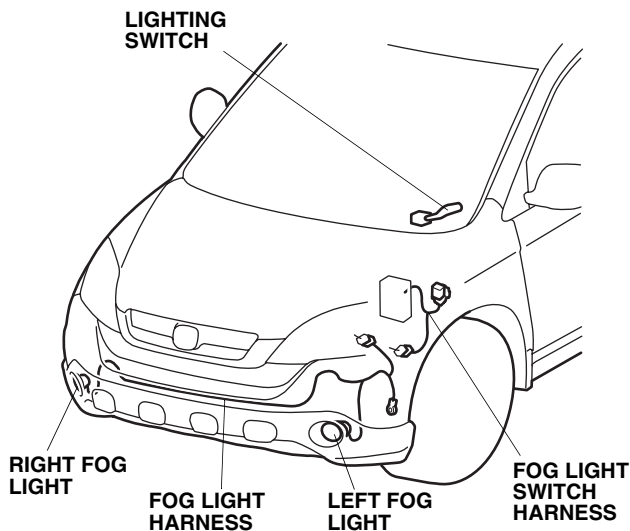

INSTALLATION

Customer Information: The information in this installation instruction is intended for use only by skilled technicians who have the proper tools, equipment, and training to correctly and safely add equipment to your vehicle. These procedures should not be attempted by “do-it-yourselfers.”

1. Make sure you have the anti-theft code for the audio and navigation system (if equipped) and write down the XM radio presets (if equipped).
2. Disconnect the negative cable from the battery.
3. Remove the front bulkhead cover (seven clips).

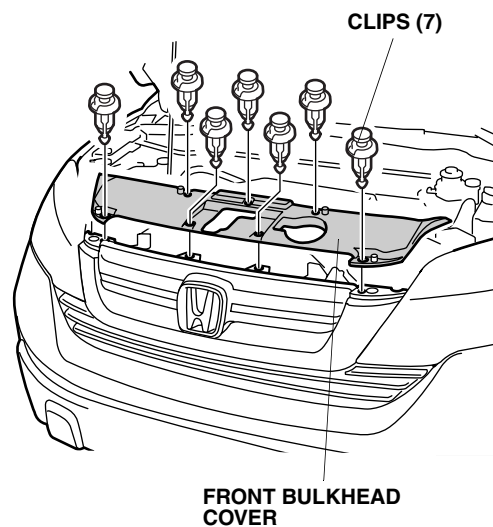

4. Remove the front bumper (four self-tapping screws, six clips and two bolts).

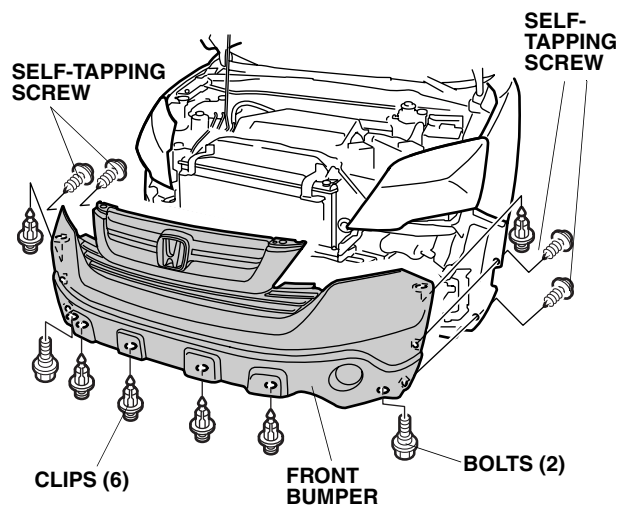

- Remove the five clips from the left inner fender pull down the left inner fender.

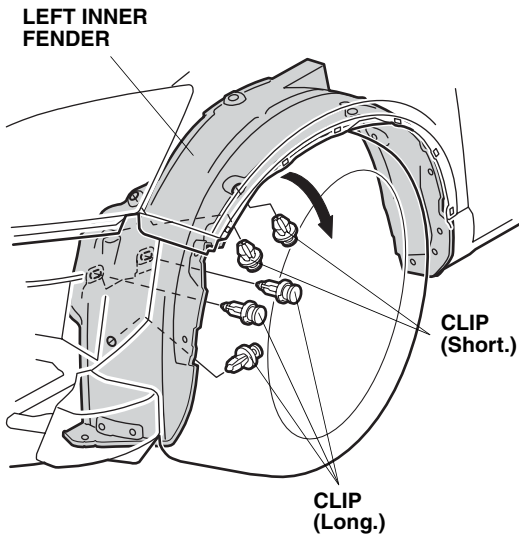

- To protect the bumper, apply masking tape to the front bumper around the left fog light opening.

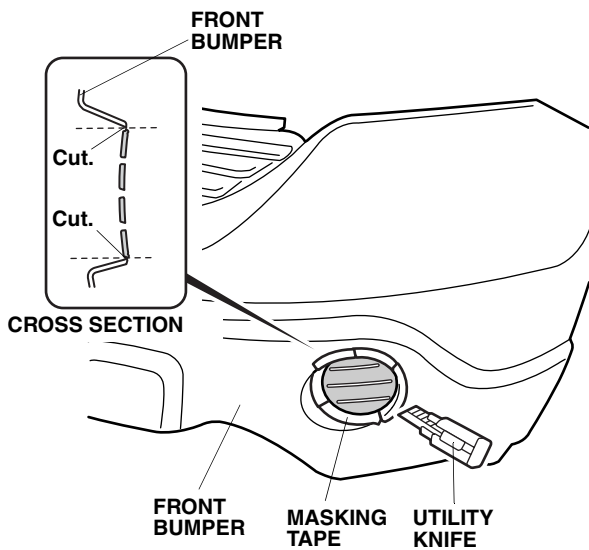

- Using a utility knife, cut out the front bumper as shown. Take care not to damage the front bumper. After cutting, remove any burrs from the edges of the hole.

- From the outside of the front bumper, install the left trim.

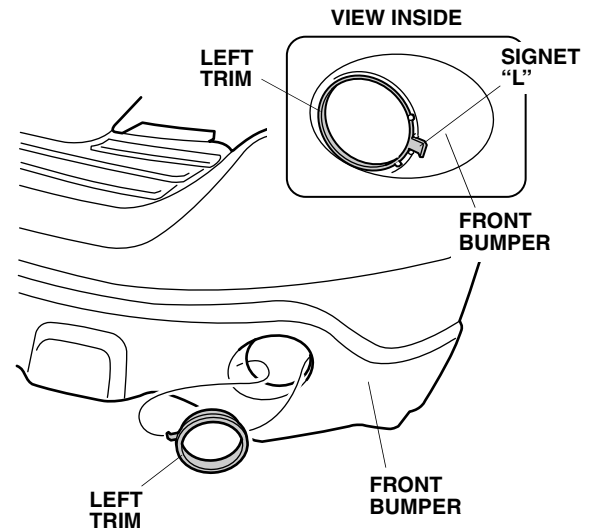

- Install the left fog light to the front bumper using four self-tapping screws.

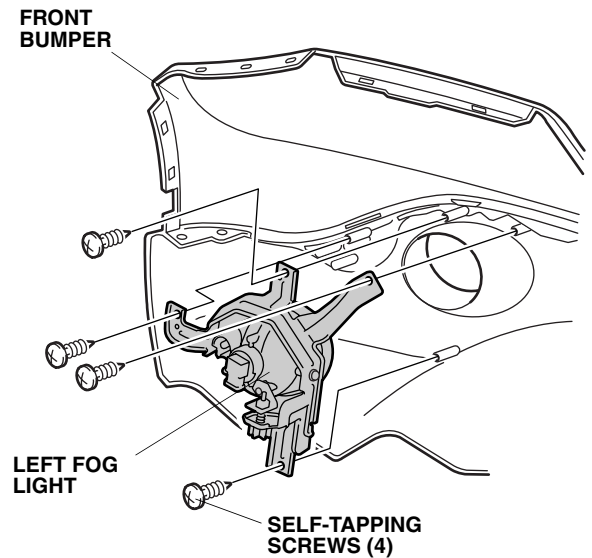

- Repeat steps 6 thru 9 to install the right fog light.

Routing the Fog Light Harness

- Route the fog light harness 1-pin connector in front of the inner fender as shown. Plug the fog light harness 1-pin connector into the vehicle harness 1-pin connector.

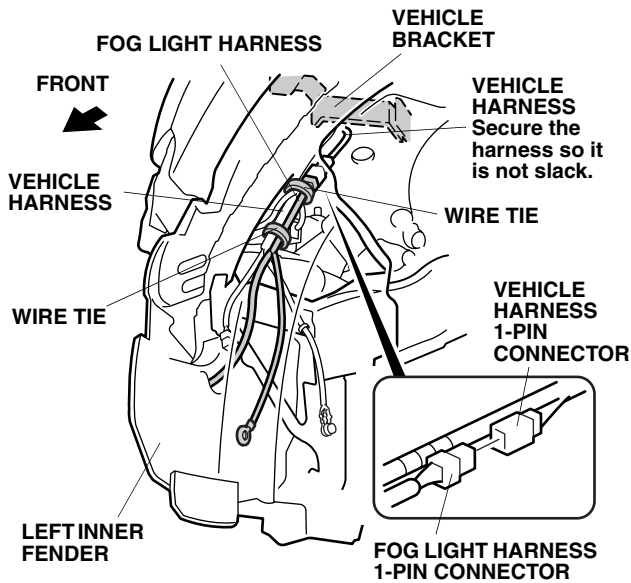

- Secure the fog light harness to the vehicle harness using two wire ties.
- Remove the vehicle ground bolt. Secure the fog light harness ground terminal to the vehicle ground terminal using the ground bolt you just removed.

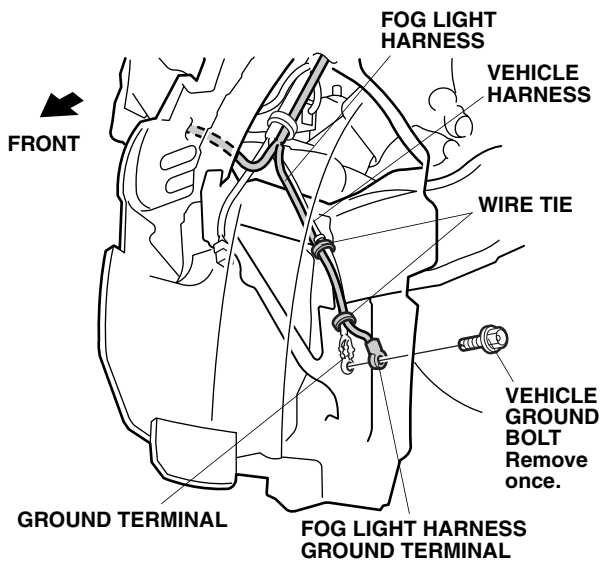

- Secure the fog light harness to the vehicle harness using two wire ties.

- Route the fog light harness under the left headlight, and secure the fog light harness clip to the vehicle panel.
- Secure the other two fog light harness clips to the holes in the resonator.

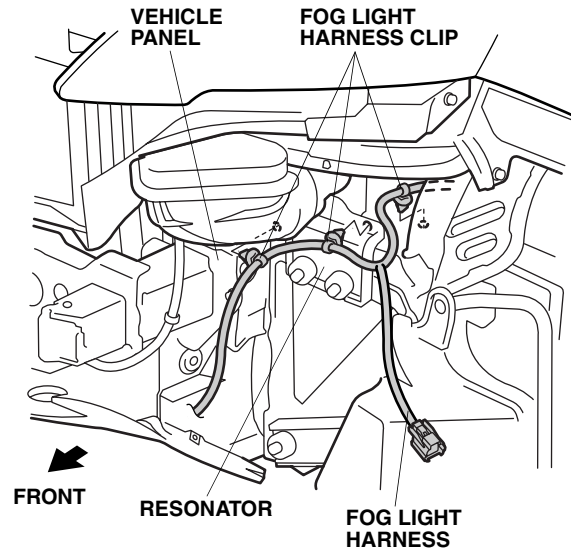

- Secure the fog light harness to the front bulkhead. **Without a Vehicle Harness:** Secure the fog light harness to the vehicle harness near the harness clips using two wire ties.

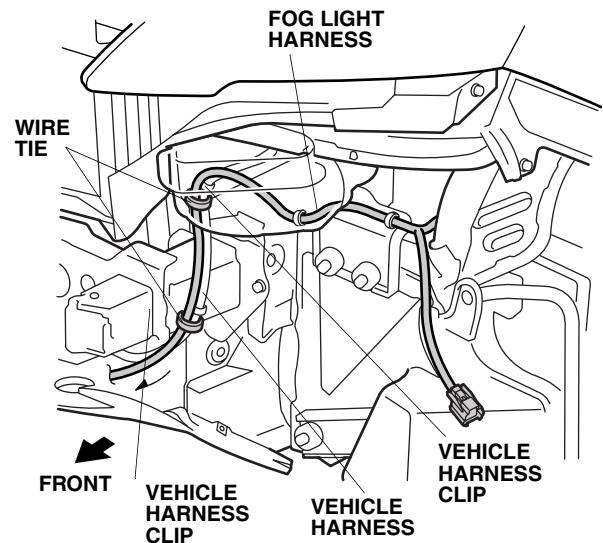

Without a Vehicle Harness: Secure the fog light harness to the vehicle panel using two wire ties with clips.

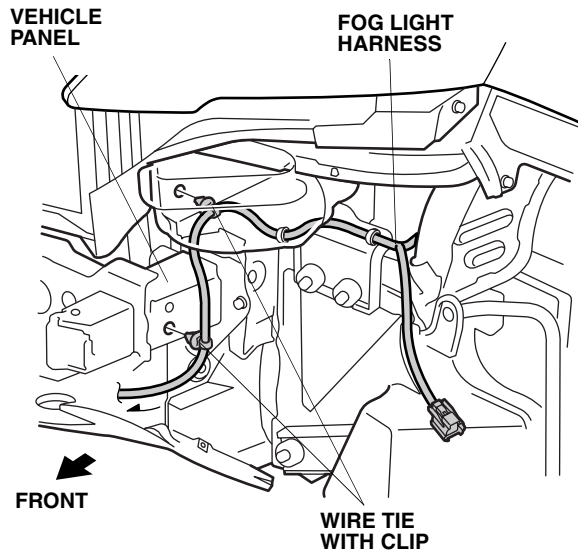

With a Vehicle Harness: Secure the fog light harness to the vehicle harness using three wire ties.

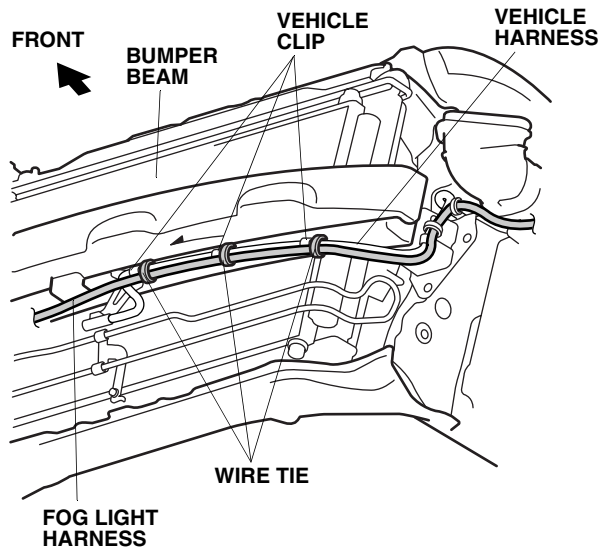

18. Route the fog light harness under the bumper beam towards the right side of the vehicle. Secure the fog light harness.

Without a Vehicle Harness: Secure the fog light harness to the bumper beam using two wire ties with clips, and one wire tie.

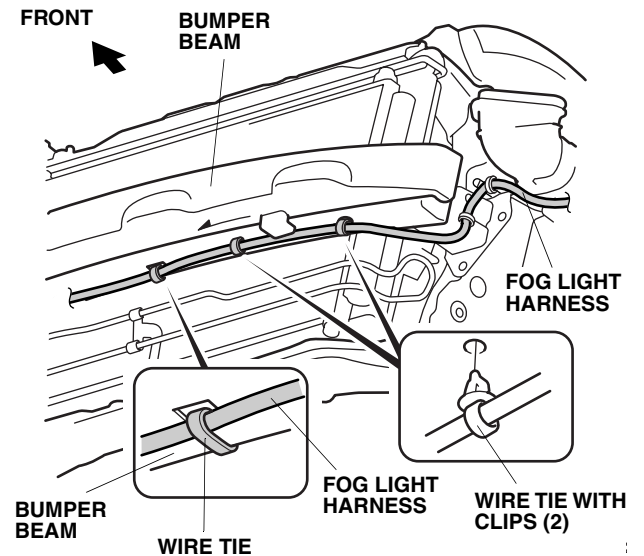

19. Using isopropyl alcohol on a shop towel, clean the bumper beam surface where the harness tape will attach.

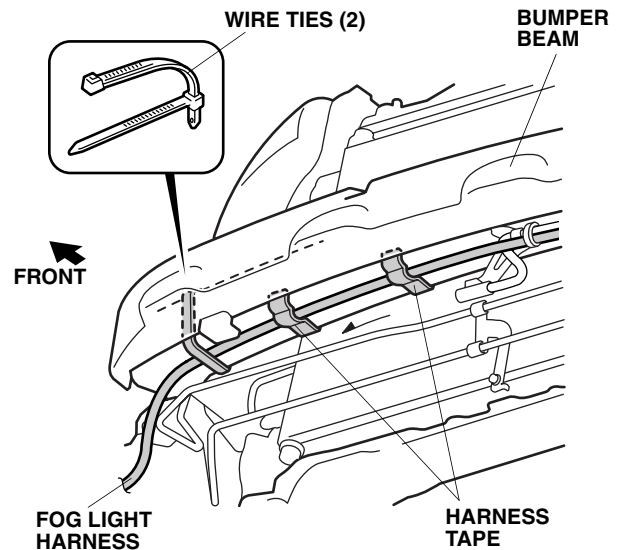

20. Continue routing the fog light harness along the bumper beam to the right side of the vehicle. Secure the fog light harness under the bumper beam using two adhesive tapes and two wire ties connected together.

21. Attach the clip on the fog light harness to the vehicle panel.

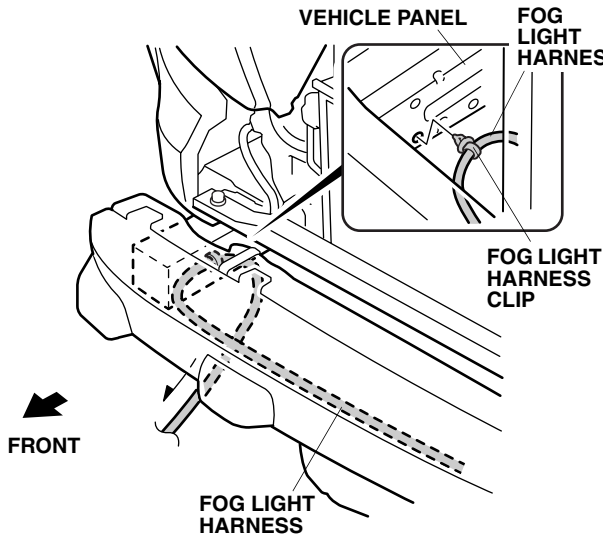

22. Secure the four remaining fog light clips to the holes in the vehicle panel.

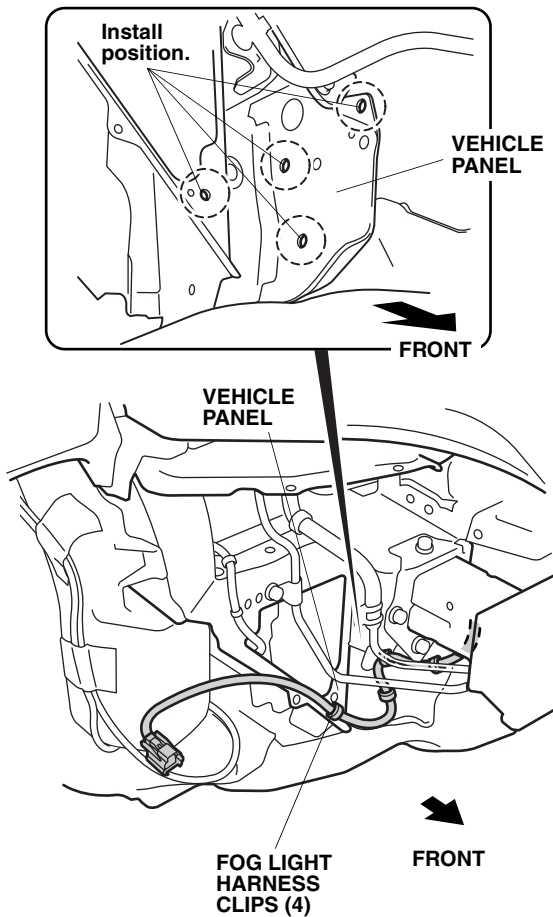

23. Reinstall the inner fender. With the help of an assistant, bring the front bumper close to the vehicle, and plug the fog light harness 2-pin connectors into the right and left fog lights. Reinstall the front bumper.

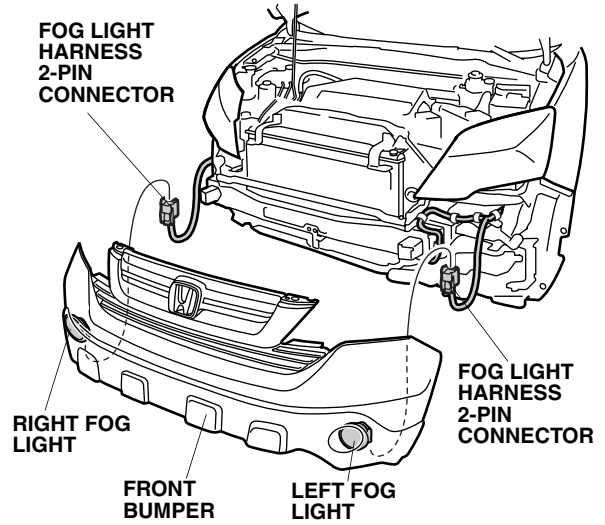

Routing the Switch Harness

24. Remove the driver's dashboard undercover (turn the knob and release the pin and clip).

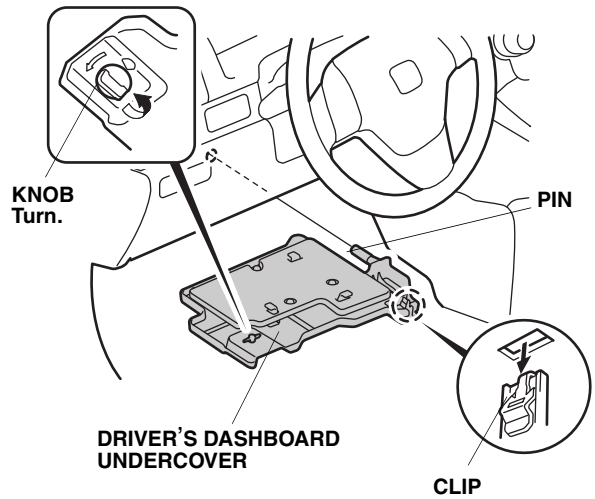

25. Remove the driver's dashboard lower cover (seven clips and two hooks).

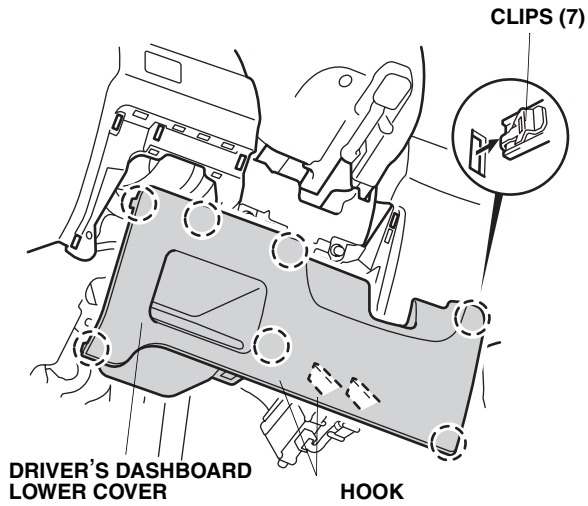

26. Remove the left front door sill trim (three clips).

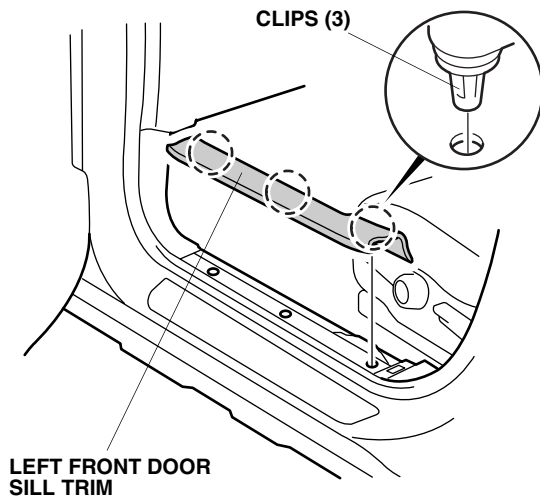

27. Pull back the door opening seal from around the driver's kick panel, and remove the driver's side kick panel (two clips).

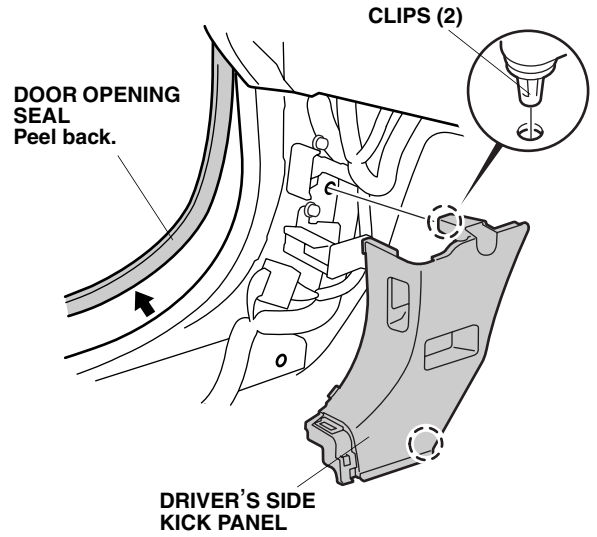

28. Lower the tilt lever. Using a flat-tip screwdriver, release one of the retaining tabs from the steering column lower cover.

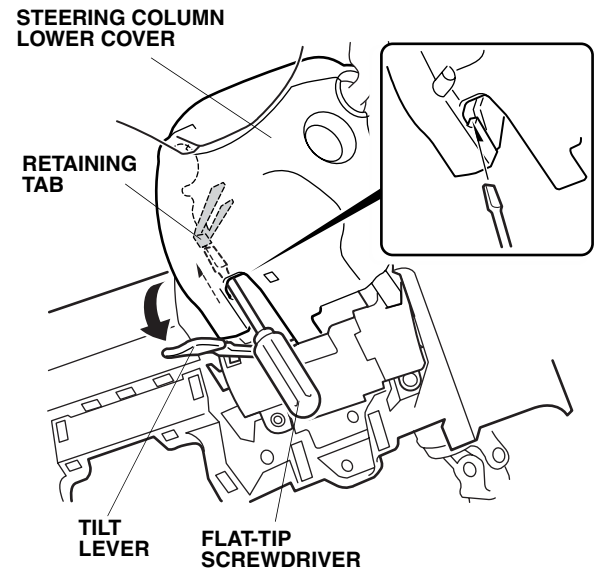

29. Remove the steering column upper cover (four retaining tabs).

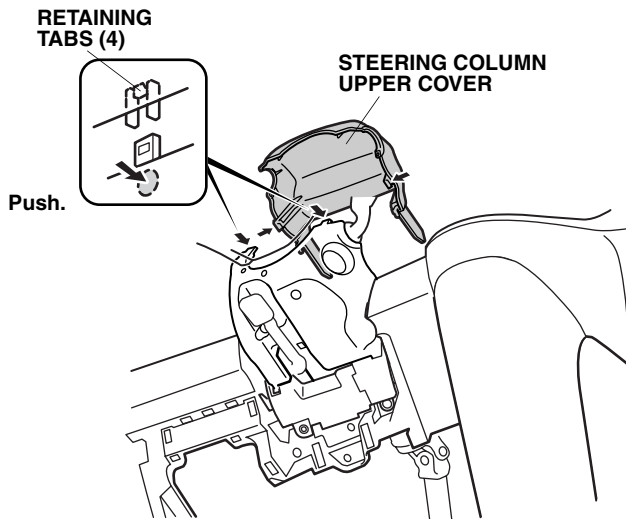

30. Remove the steering column lower cover (two self-tapping screws and one screw).

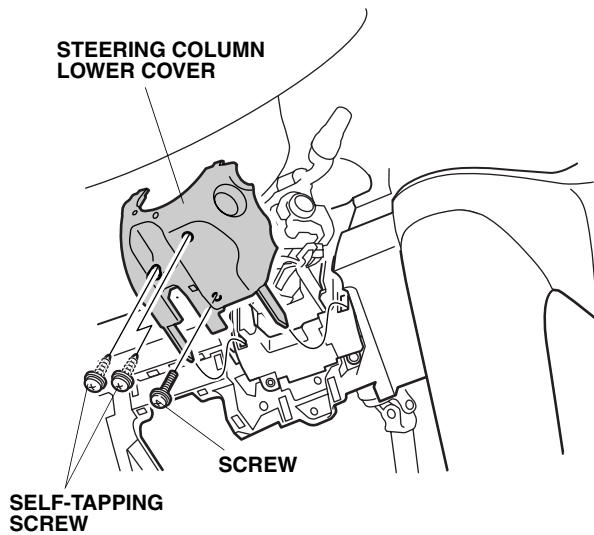

31. Plug the relay into the switch harness relay block.

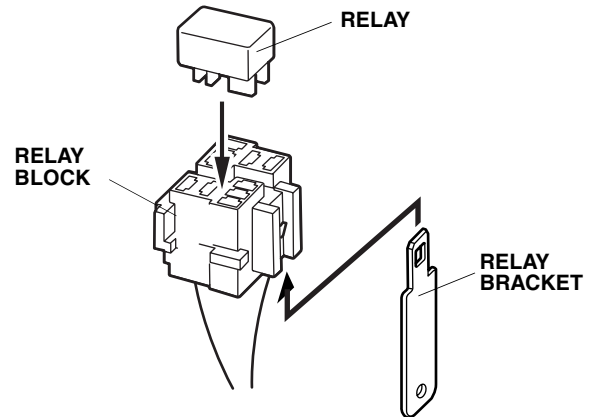

32. Install the relay bracket to the switch harness relay block.
33. Install the switch harness relay block on the vehicle panel using the 6 x 16 mm washer-bolt and 6 mm flange nut.

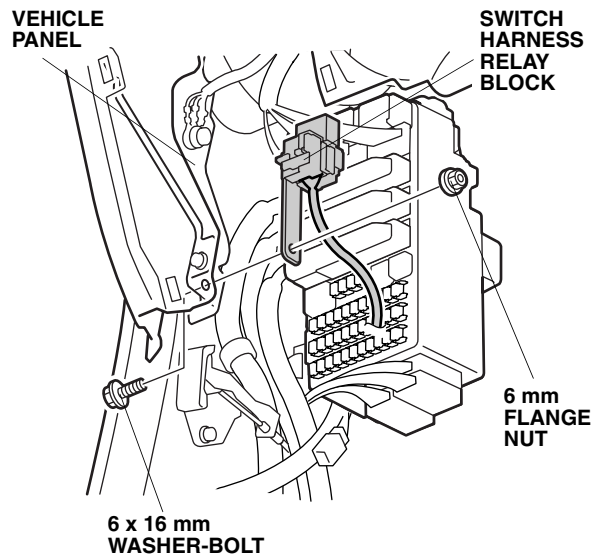

34. Plug the switch harness 2-pin connector into the vehicle harness 2-pin connector. Secure the switch harness to the vehicle harness using two wire ties.

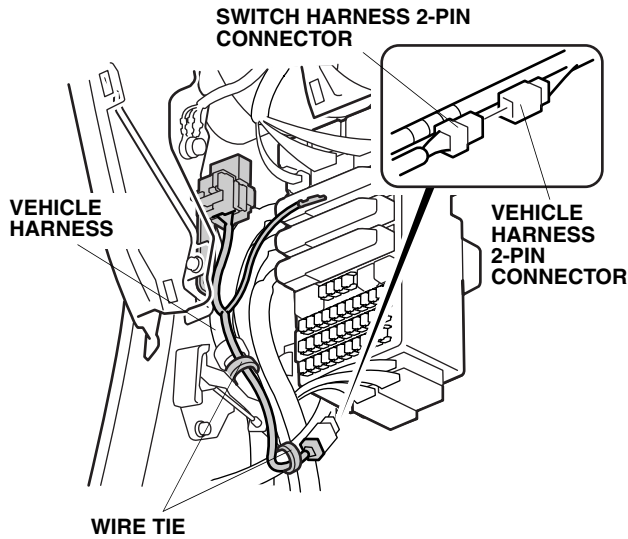

35. Push the retaining tab (from the vehicle green 42-pin connector, the white 34-pin connector, and the blue 21-pin connector), and raise the lock lever from each connector. Remove the connectors from the fuse box. Close the lock on the vehicle white 34-pin connector, and remove the cover by sliding it away from the lock.

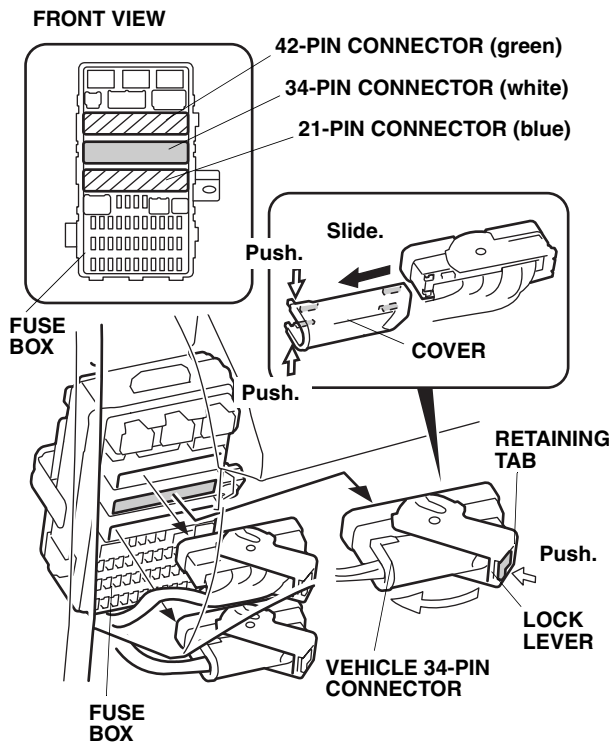

36. Insert the white and pink switch harness terminals into the appropriate cavities of the vehicle white 34-pin connector.

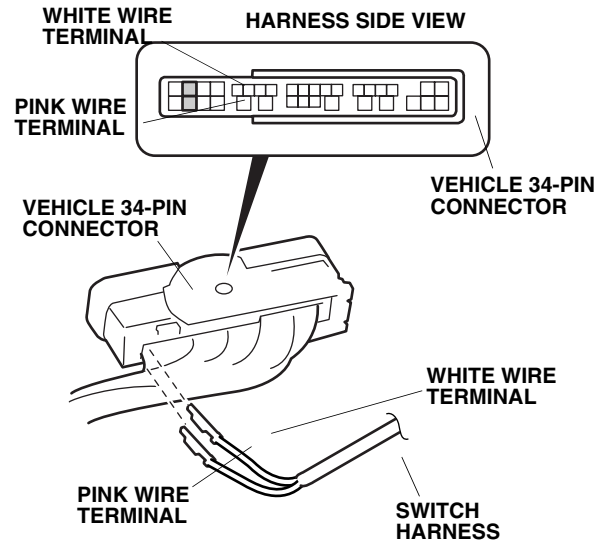

37. Reinstall the connector cover and reconnect the connectors.

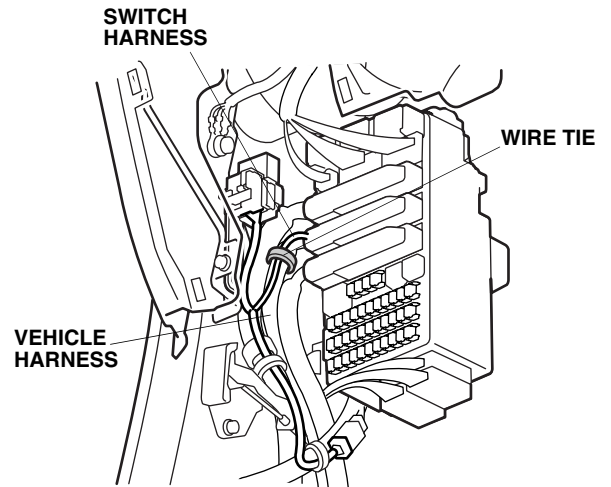

38. Secure the switch harness to the vehicle harness using one wire tie.

39. Turn the steering wheel 90° counterclockwise, and unplug the vehicle connector from the light switch.

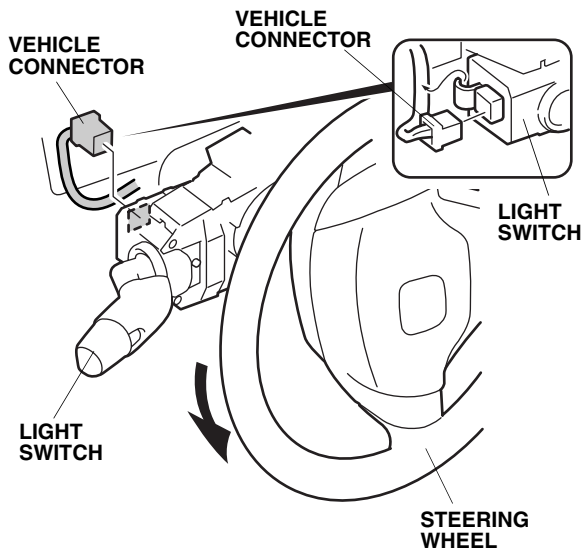

40. Remove the two self-tapping screws from the light switch. While pushing the retaining tab, slide the light switch, and remove it from the steering column. While removing, do not hold the light switch by the lever.

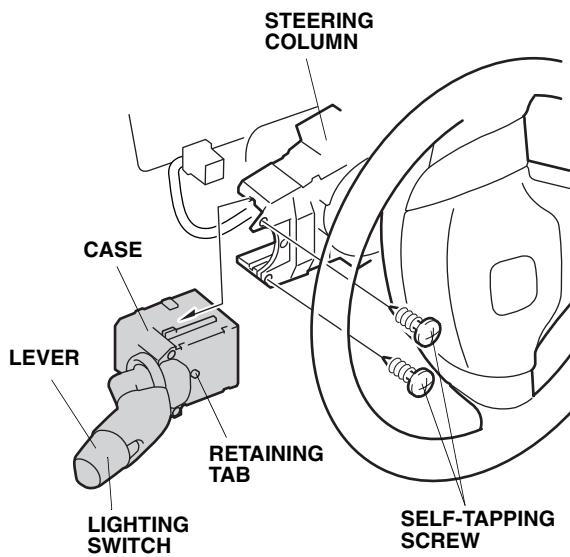

41. Install the new light switch on the steering column using the two self-tapping screws. While installing, do not hold the light switch by the lever.

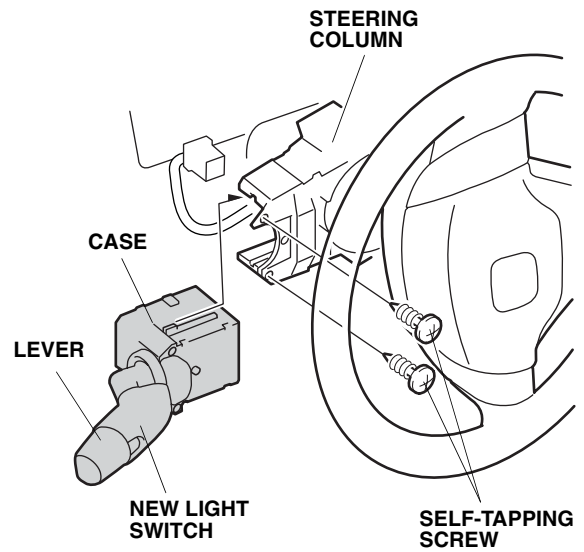

42. Plug the vehicle connector into the new light switch.

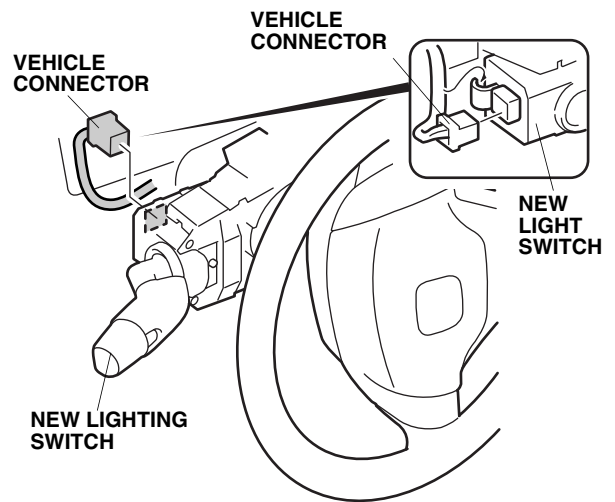

If the vehicle you are working on is a EX-L Model, go to step 44; otherwise, continue with step 43.

43. Install the 20A fuse into the fuse box in the location shown.

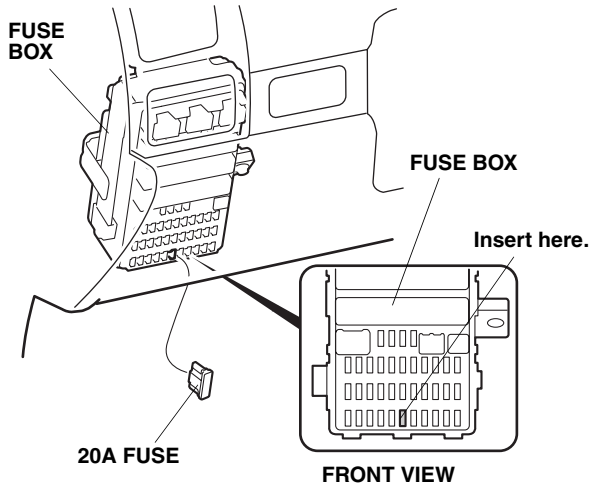

44. Check that all wire harnesses are routed properly and all connectors are plugged in.
45. Reinstall all removed parts. Do not reinstall the bumper clip and bolts that fasten the bumper at this time. Check that all clips and fasteners are installed securely.
46. Reconnect the negative cable to the battery.
47. Reset the clock, and reset the XM radio presets (if equipped).

USE AND CARE

Fog Light Aiming Adjustment

48. Adjust the fog light:
 - Pull down the inner fender and under cover.
 - Adjust the aiming according to local laws and regulations.
 - To adjust, turn the aiming adjustment knob in or out until the correct aiming is obtained.
49. Reinstall the bumper clips and bolts and securely tighten the bolts.

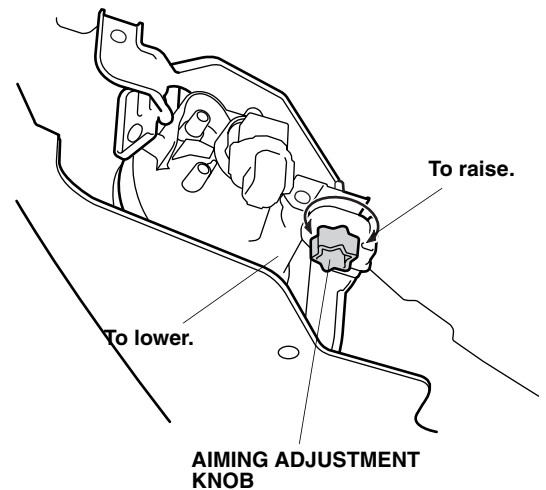

How to Operate Fog Lights

- Turn the lights switch to the "D" position (headlights on low beam).
- Turn the fog light switch on (indicator is on).

NOTE: The fog light lenses can cloud when the outside temperature is cold; this is normal and should go away in warm weather.

- If the fog light don't come on, check the fuse and all the connectors, including the ground cable.

BULB REPLACEMENT

1. Remove the bolt and clip, and turn down the under cover and inner fender.

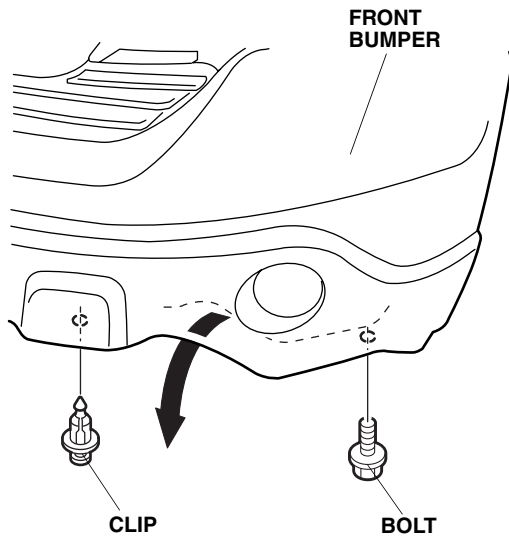

2. Unplug the connector from the fog light.
3. Remove the bulb.

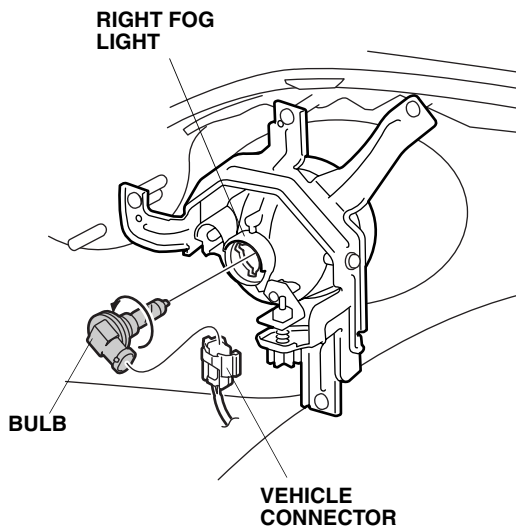

4. Install the new bulb and socket to the fog light. Use only a genuine Honda halogen light bulb of specified wattage.

Rating: 12V 55W H11 Halogen Light Bulb
P/N 33165-S5A-003

- Do not touch the bulb. Oily or greasy substances on the bulb can shorten its service life due to the heat produced when the bulb is turned on. If the bulb is accidentally touched, wipe it clean with a soft cloth that has been dampened with a denatured alcohol or a mild detergent solution.
- Align the tab on the fog light with the cutout in the bulb when installing the new bulb. If not aligned, the fog light may annoy oncoming driver's.

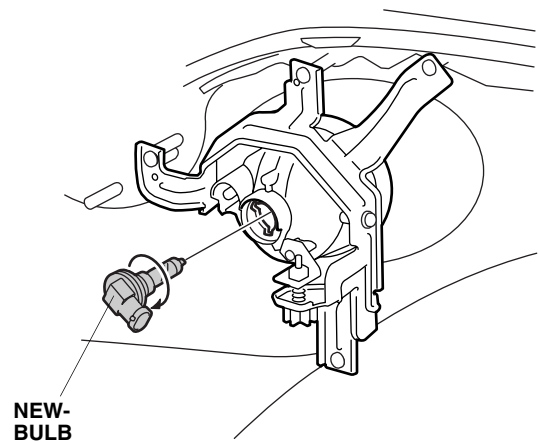

5. Reinstall the removed parts in the reverse order of removal.
 - Check that the wire harnesses are not pinched.
 - Be sure to tighten the clip and bolts securely.
6. Check the operation of the fog light; adjust the aiming if necessary.

CIRCUIT DIAGRAM

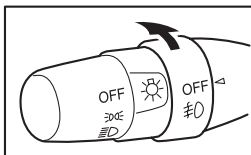
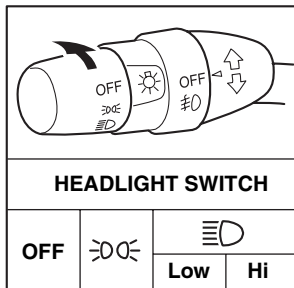
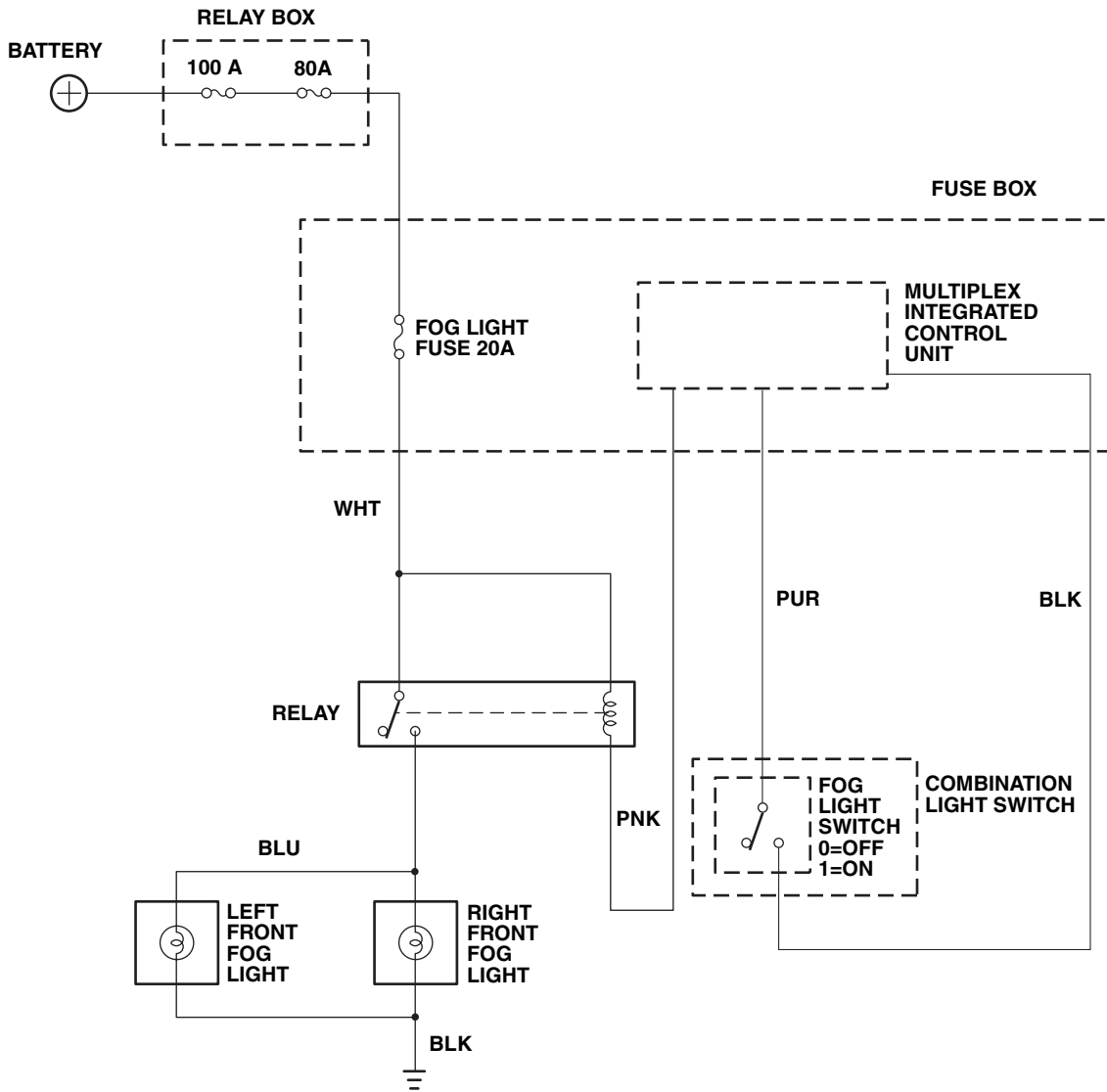

FOG LIGHT SWITCH	OFF	☀	☹	
			Low	Hi
☹	-	-	-	-
☹	-	-	ON	-

BLK	BLACK	BRN	BROWN
YEL	YELLOW	ORN	ORANGE
BLU	BLUE	PUR	PURPLE
GRN	GRNEEN	NAT	NATURAL
RED	RED	PNK	PINK
WHT	WHITE	GRY	GRAY
LT BLU	LIGHT BLUE	LT GRN	LIGHT GREEN

6906010B