



INSTALLATION INSTRUCTIONS

Accessory

**SECURITY SYSTEM
(VP, LX, SE)**

Application

**2007 ACCORD
2 AND 4-DOOR**

Publications No.

All 32649

Issue Date

JULY 2006

PARTS LIST

**Security System Attachment:
P/N 08E55-SDA-100A**

Unit panel bracket

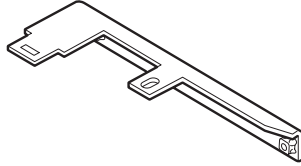

Unit lower cover bracket

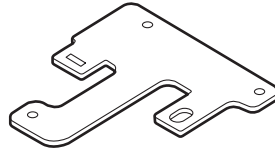

Security harness

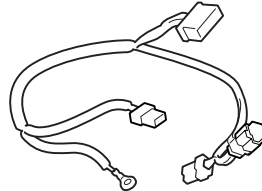

Ground bolt



2 Washer-screws



8 Wire ties

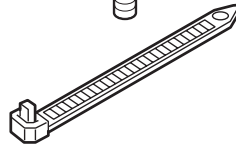

Fuse (3A)



Fuse label

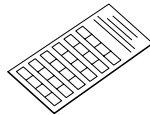

3 Self-tapping screws



Owner's Manual



**Security System (sold separately):
P/N 08E51-SDA-101A**

Security unit

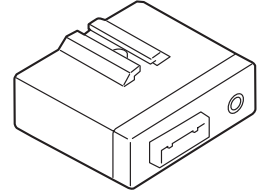

Security label

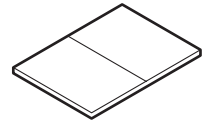

Microphone

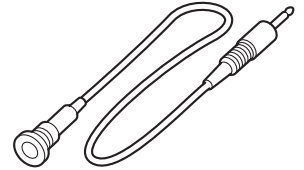

TOOL AND SUPPLIES REQUIRED

#2 Phillips screwdriver

Small flat-tip screwdriver

Felt-tip pen

10 mm Combination wrench

10 mm Socket

Ratchet

3 mm and 8 mm Drill bits

Eye protection (face shield, safety goggles, etc.)

File

Diagonal cutters

Tape measure

Illustration of the Security System Installed on the Vehicle

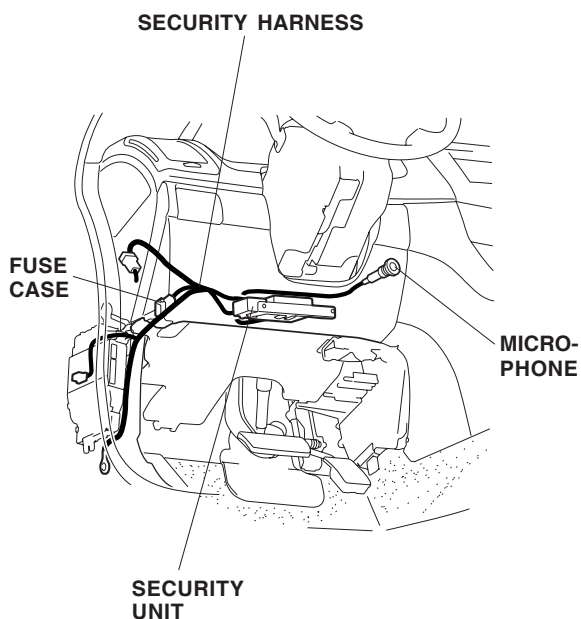

INSTALLATION

Customer Information: The information in this installation instruction is intended for use only by skilled technicians who have the proper tools, equipment, and training to correctly and safely add equipment to your vehicle. These procedures should not be attempted by “do-it-yourselfers.”

1. Make sure you have the anti-theft code for the radio, then write down the frequencies for the preset buttons.
2. Disconnect the negative cable from the battery.

3. Remove the driver's dashboard lower cover:
 - Remove the self-tapping screw.
 - Release the four clips on the left side first by pulling out on the driver's dashboard lower cover.
 - After releasing the four clips, insert the flat-tip screwdriver between the clip and the dashboard frame. Gently twist the screwdriver to release the clip.
 - Release the two clips on the right side.
 - Unplug the vehicle connector, and remove the lower cover.

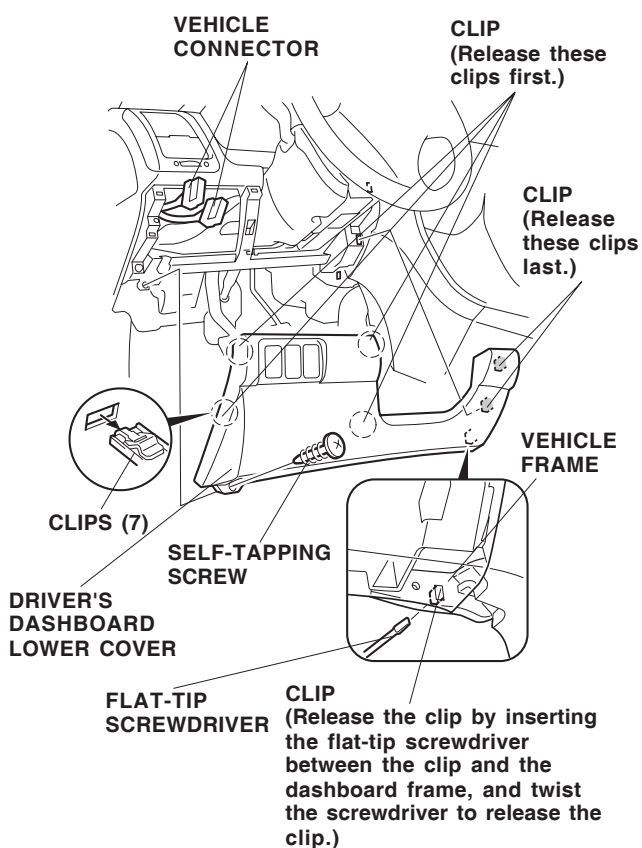

- If equipped, remove the driver's dashboard under cover (release the three retaining clips, one pin, and one holder).

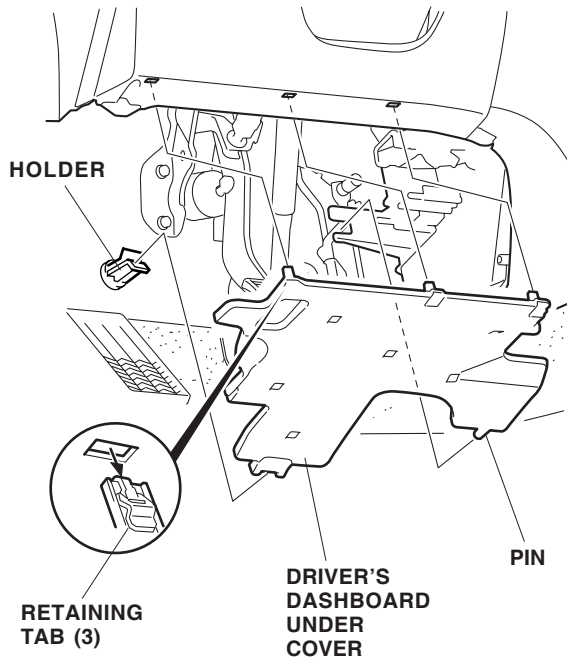

- Remove the cap (six retaining tabs), and remove the self-tapping screw.

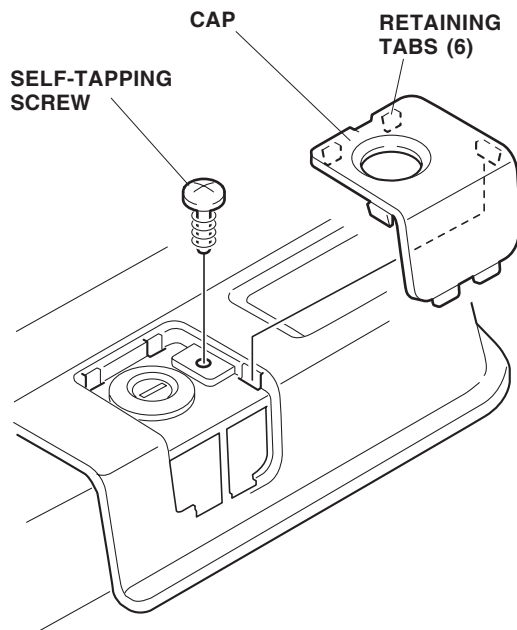

- Remove the left-front door sill trim (five clips and four tabs).

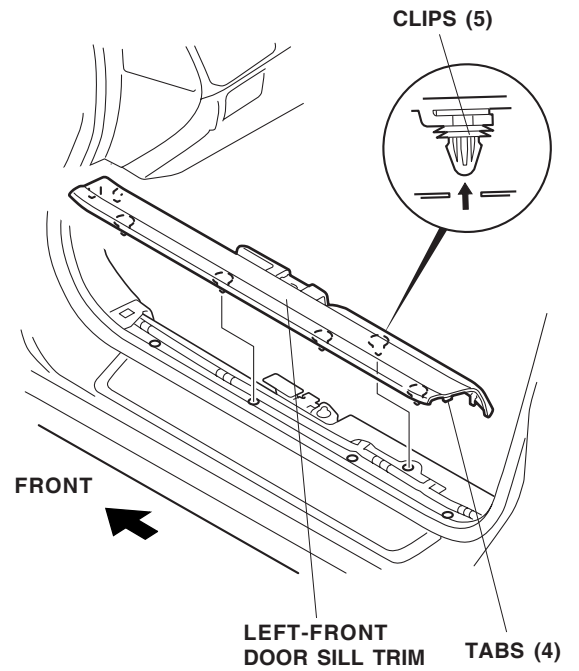

- Remove the fuse box cover by sliding it toward you.

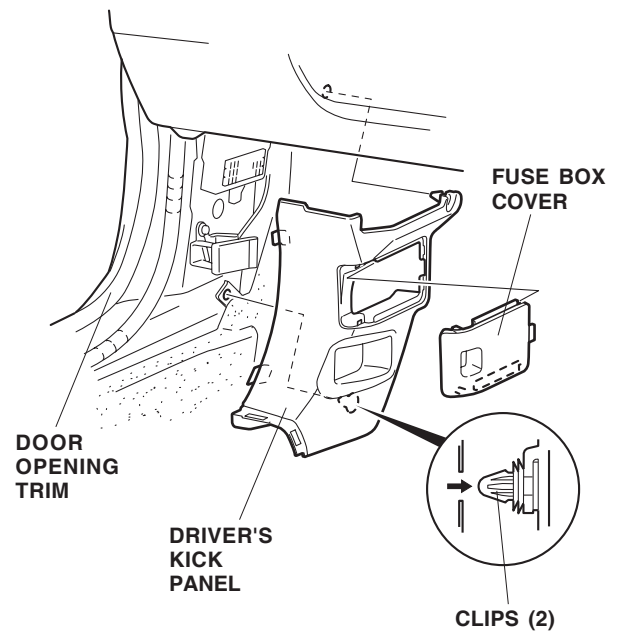

- Remove the driver's side front door opening trim in the area shown, and remove the driver's kick panel by releasing the two clips.

9. Plug the 6-pin connector of the security harness into the fuse box.

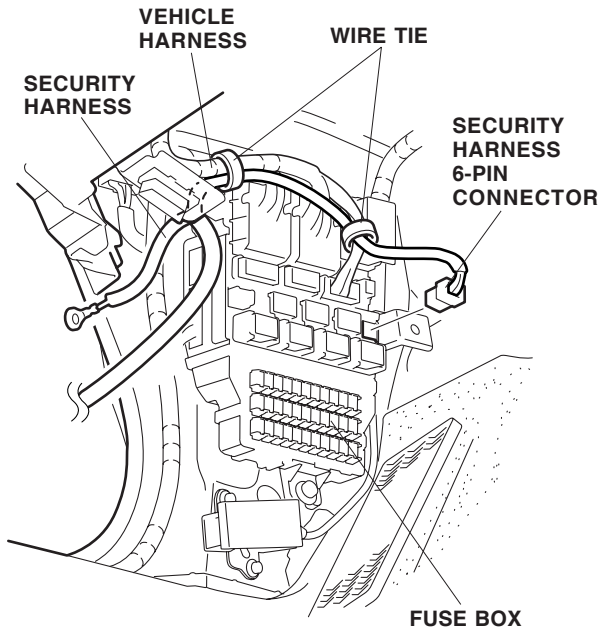

10. Attach the security harness to the vehicle harness with two wire ties.

NOTE: If the 6-pin connector is already being used by another accessory, locate the 6-pin connector taped to the other accessory's harness. Remove the dummy connector from the other accessory's harness. Plug the security harness 6-pin connector into the other accessory's harness.

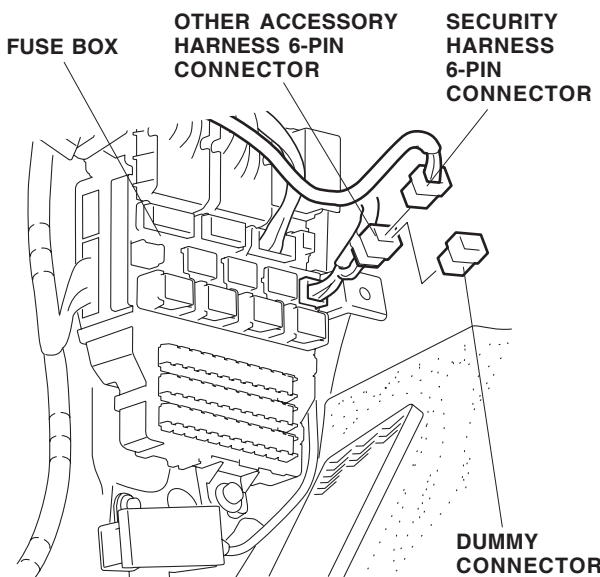

11. Route the ground terminal of the security harness along the vehicle harness. Remove upper bolt from the hood opener, and install the ground terminal using a new ground bolt.

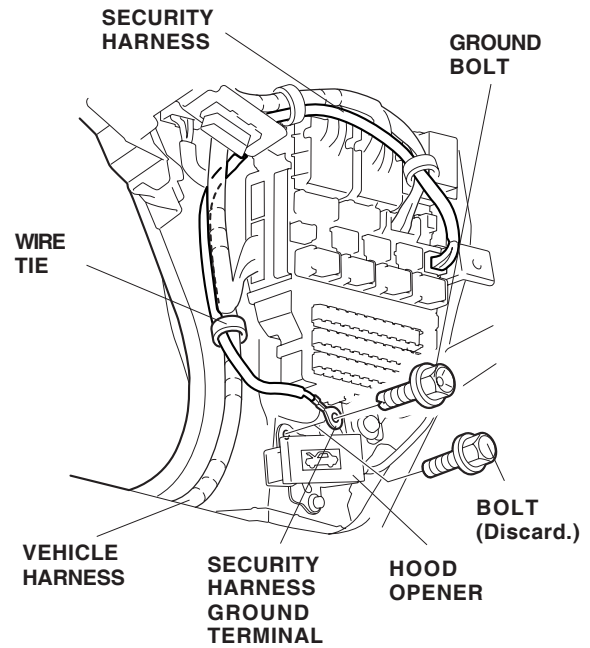

12. Attach the security harness to the vehicle harness with one wire tie.

If the vehicle is equipped without a dashboard under cover, continue with step 13; otherwise, go to step 16.

13. *Without dashboard under cover:* Slide the security unit into the unit panel bracket. Do not push on the connector area.

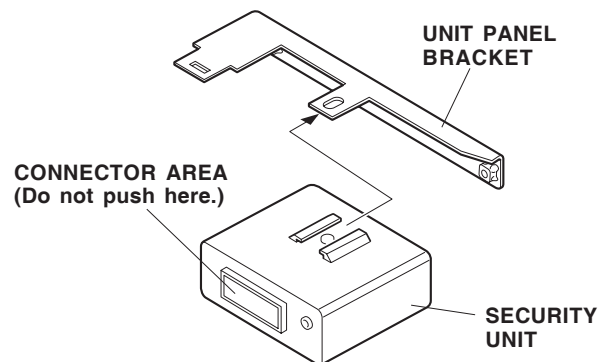

14. *Without dashboard under cover:* Attach the unit panel bracket to the instrument panel with two washer-screws.

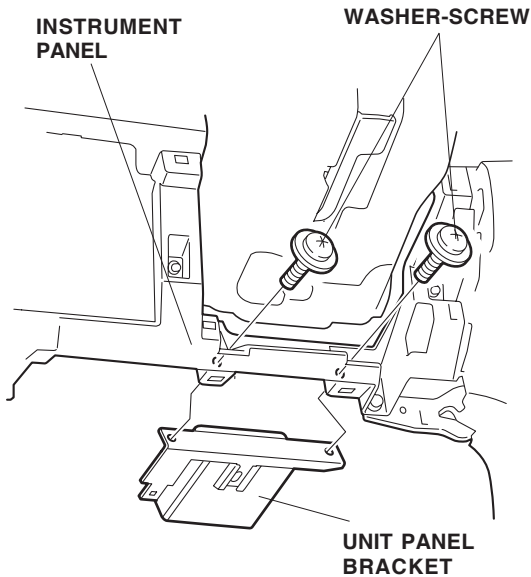

15. *Without dashboard under cover:* Plug the 18-pin connector of the security harness into the security unit. Loosely attach the security harness to the vehicle harness with one wire tie. Go to step 19.

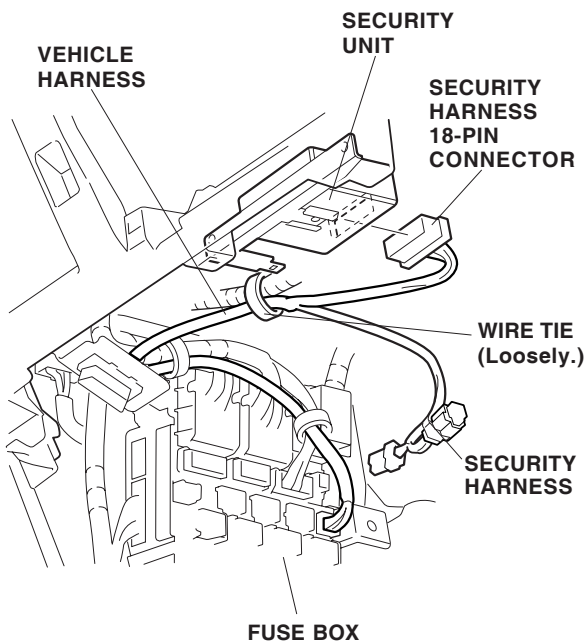

16. *With dashboard under cover:* Slide the security unit into the unit lower cover bracket. Do not push on the connector area.

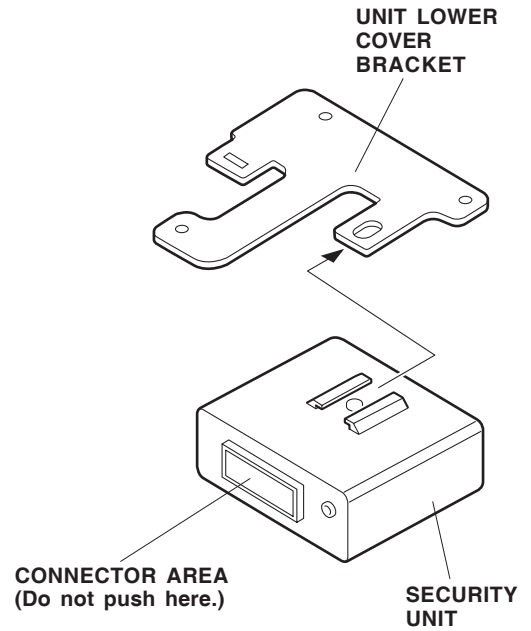

17. *With dashboard under cover:* Attach the unit lower cover bracket to the dashboard under cover with three self-tapping screws.

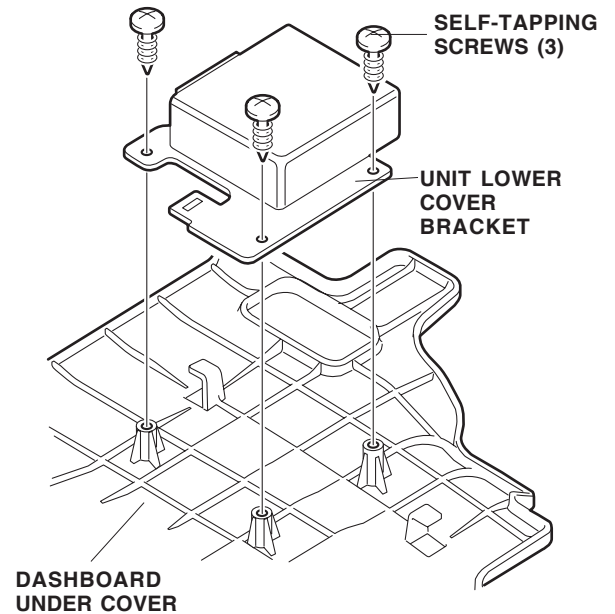

18. *With dashboard under cover:* Loosely attach the security harness to the vehicle harness with one wire tie.

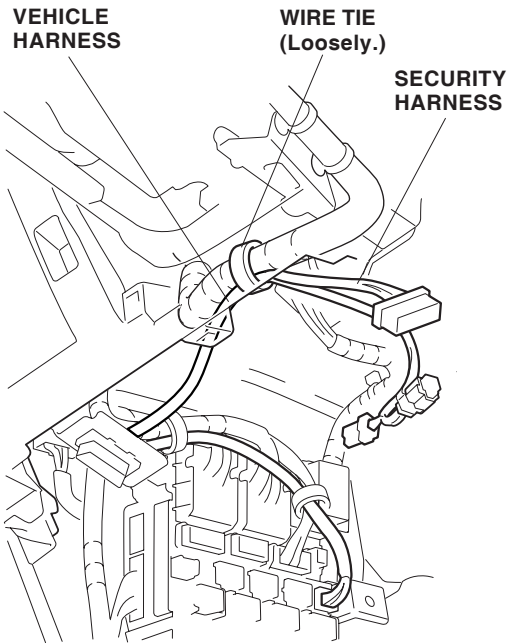

19. On the left of the steering shaft, locate the 3-pin connector blue-taped to the vehicle harness, and connect the security harness 3-pin connector to that 3-pin connector.

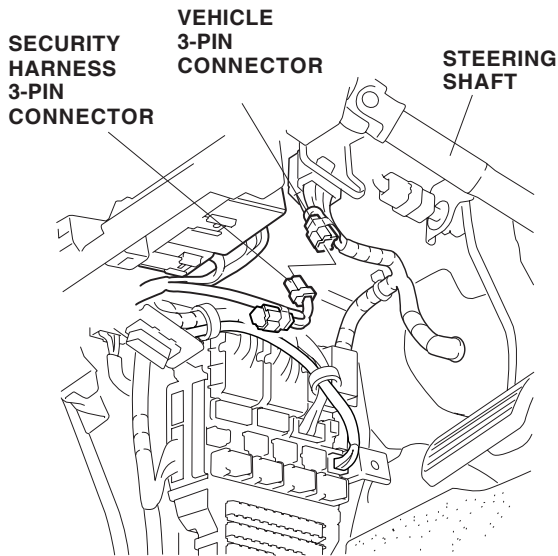

NOTE: If the 3-pin connector is already being used by another accessory, locate the 3-pin connector taped to the other accessory's harness. Remove the dummy connector from the other accessory's harness. Plug the security harness 3-pin connector into the other accessory's harness.

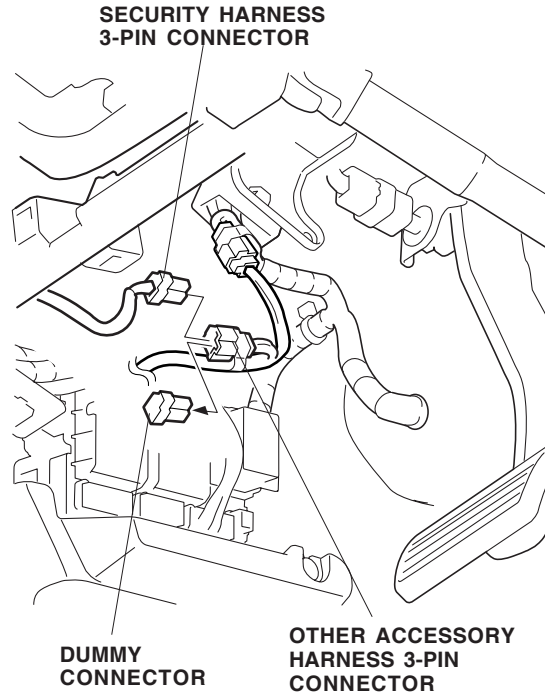

20. Using a tape measure and felt-tip pen, measure and mark the driver's dashboard lower cover.

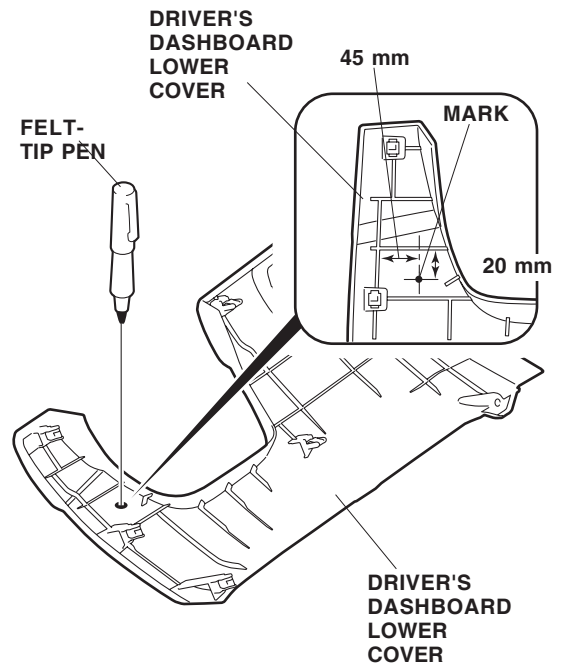

21. While wearing eye protection, drill an 8 mm hole through the felt-tip mark. First drill a 3 mm bit, then finish with an 8 mm bit. Remove all burrs.

DRILL
(First drill with a 3 mm drill bit,
then finish with an 8 mm drill bit.)

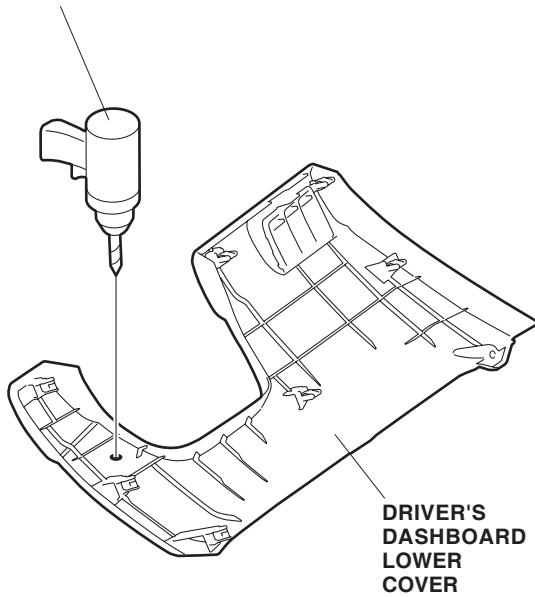

22. Route the microphone jack through the hole you just drilled and secure it.

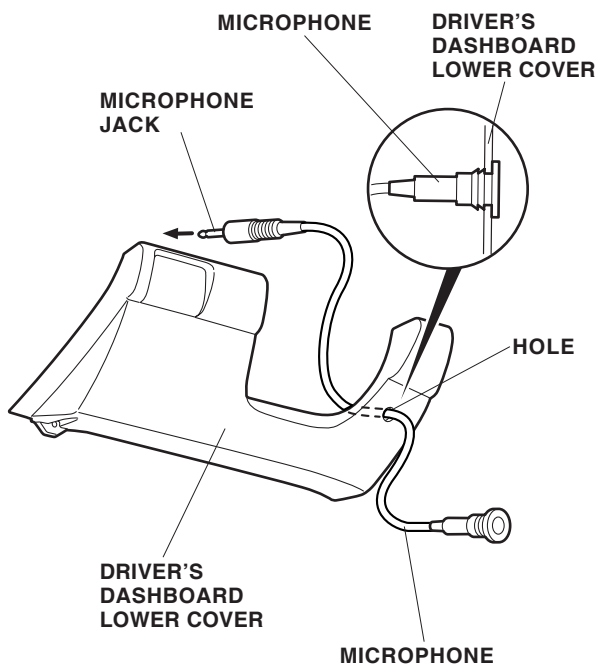

23. *Without dashboard under cover:* Connect the microphone jack to the security unit, and secure the microphone cord to the vehicle panel with one wire tie. Reinstall the dashboard lower cover. Fold the excess length of the microphone cord, and secure the microphone cord to the security harness with two wire ties.

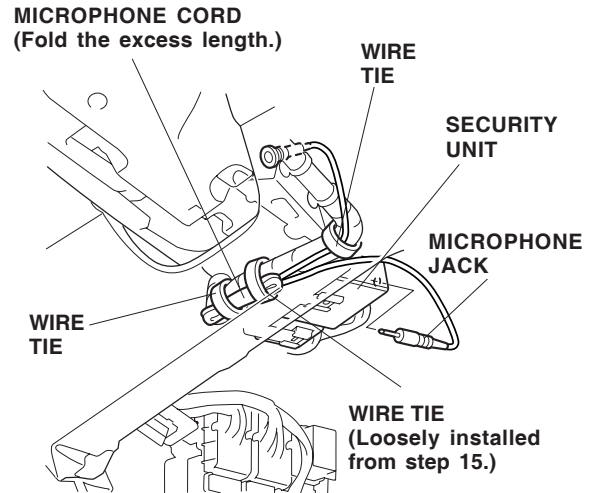

24. *With dashboard under cover:* Measure and fold the excess length of the microphone cord, and secure the microphone cord to the security harness with one wire tie.

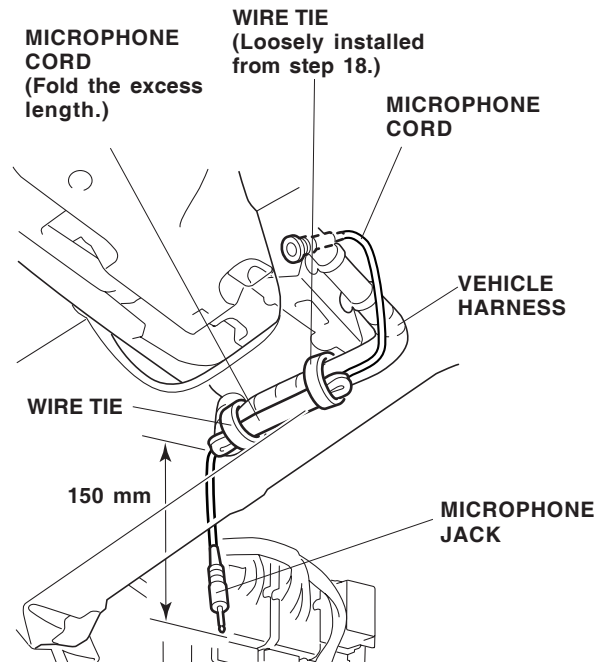

25. Attach the security harness to the vehicle harness with one wire tie.

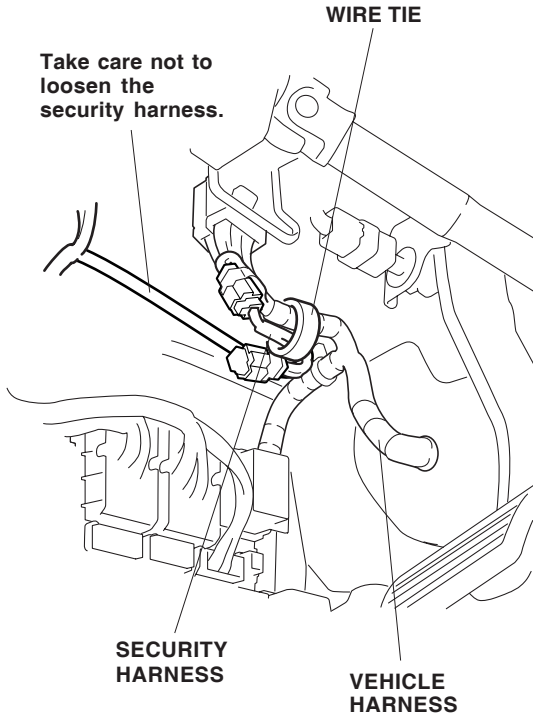

26. Plug the security harness 18-pin connector and microphone jack into the security unit.

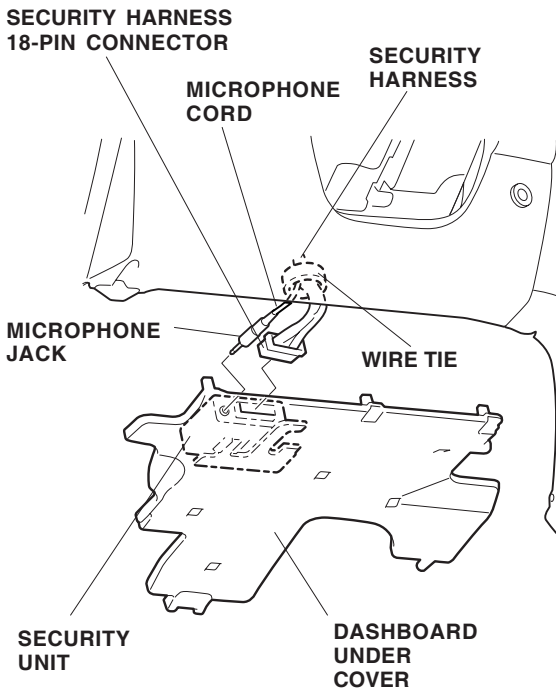

27. Attach the microphone cord to the security harness with one wire tie. Reinstall the dashboard under cover.

28. Secure the microphone cord to the security harness with one wire tie. Reinstall the dashboard under cover.
29. Install the fuse (3A) provided into the No. 33 slot of the fuse box.

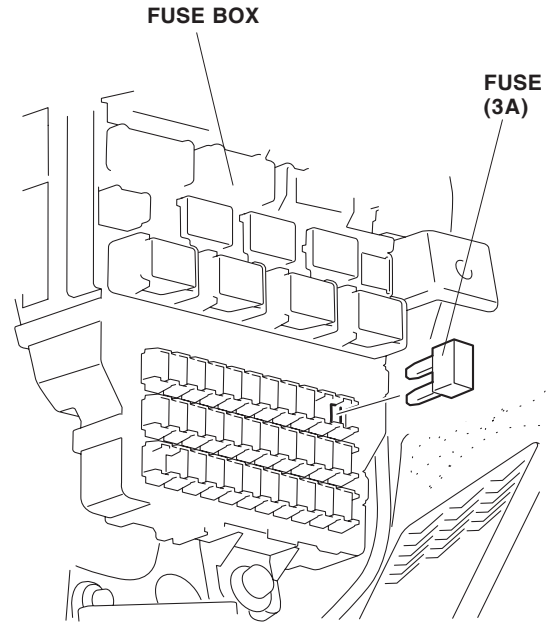

30. Attach the fuse label (OPTION FUSE 3A) over the No. 33 on the back of the fuse box cover.

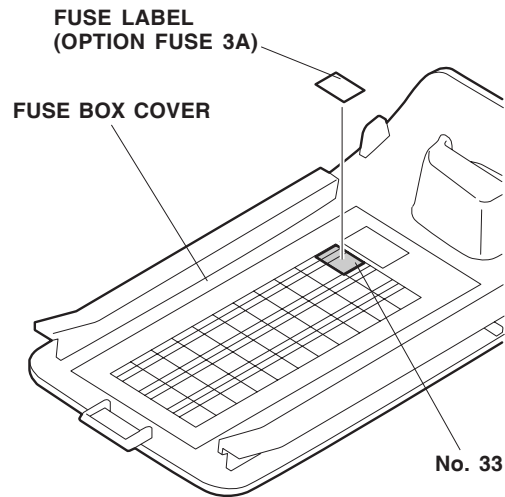

31. Check that all wire harnesses are routed properly and all connectors are plugged in.
32. Check that all wire ties are secured.
33. Reinstall all removed parts.
34. Reconnect the negative cable to the battery.
35. Enter the customer's radio anti-theft code, and reset the radio station presets.
36. Reset the clock.
37. Check the operation of the security system according to the Security System owner's manual.

NOTE: Whenever the battery is disconnected, the driver's window AUTO function is disabled.

38. Start the engine. Push down on the driver's window switch until the window is fully open.
39. Pull up on the driver's window switch to close the window completely, then hold the switch for a second or 2 more.
40. Test the driver's window AUTO function.