



# INSTALLATION INSTRUCTIONS

| Accessory             | Application                 | Publications No.        |
|-----------------------|-----------------------------|-------------------------|
| CENTER PANEL TRIM KIT | 2007 ACCORD<br>2 AND 4-DOOR | All 32656               |
|                       |                             | Issue Date<br>JULY 2006 |

## PARTS LIST

Center Panel Trim Kit (with seat heaters)  
P/N 08Z03-SDA-121B (Burlwood)  
P/N 08Z13-SDA-110D (Metal)  
P/N 08Z03-SDA-132B (Wood)

Center pocket trim

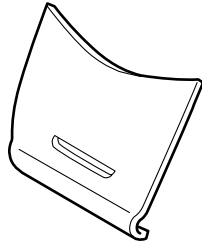

Trim ring trim

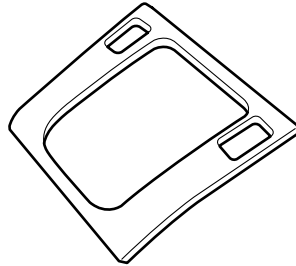

Film

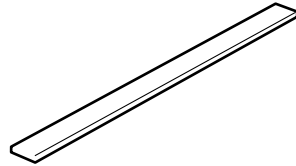

Adhesive

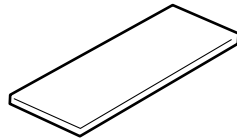

Center Panel Trim Kit (without seat heaters)  
P/N 08Z03-SDA-110J (Burlwood)  
P/N 08Z13-SDA-110F (Metal)  
P/N 08Z03-SDA-120J (Wood)

Center pocket trim

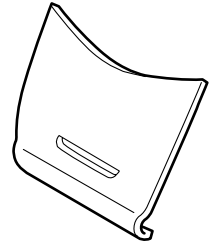

Trim ring trim

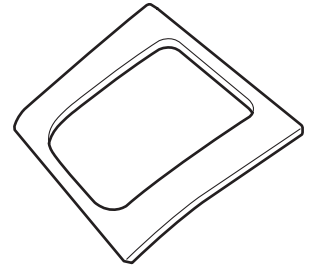

Film

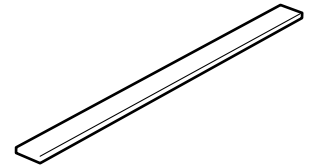

Adhesive

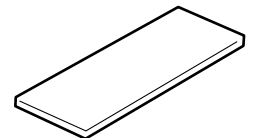

## SUPPLIES REQUIRED

Isopropyl alcohol  
Shop towel  
Masking tape  
Scale

## INSTALLATION

NOTE: This center panel trim kit should be installed only if the outside air temperature is 60°F (15°C) or above.

### Installing the Center Pocket Trim

*If the center pocket lid is not black, start with step 1. If it is black, go to step 3.*

1. Using isopropyl alcohol on a shop towel, thoroughly clean the area where the film will attach.

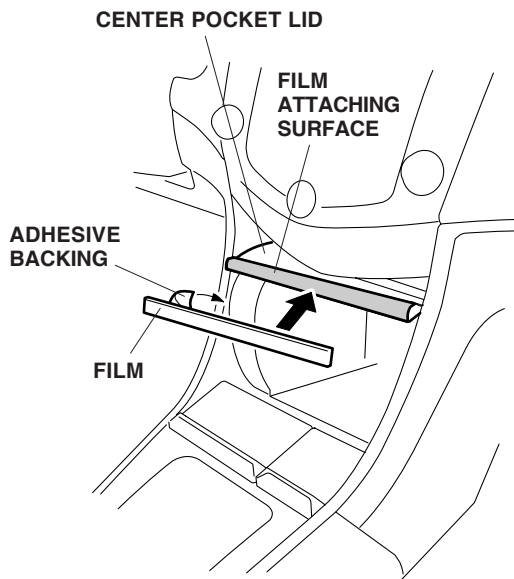

2. Remove the adhesive backing from the film, and attach it to the center pocket lid aligning the lower edge of the film with the lower end of the curved surface of the center pocket lid.

*If the center pocket lid is black, start with step 3. If the center pocket lid is not black, go to step 5.*

3. Using isopropyl alcohol on a shop towel, thoroughly clean the area where the adhesive will attach.

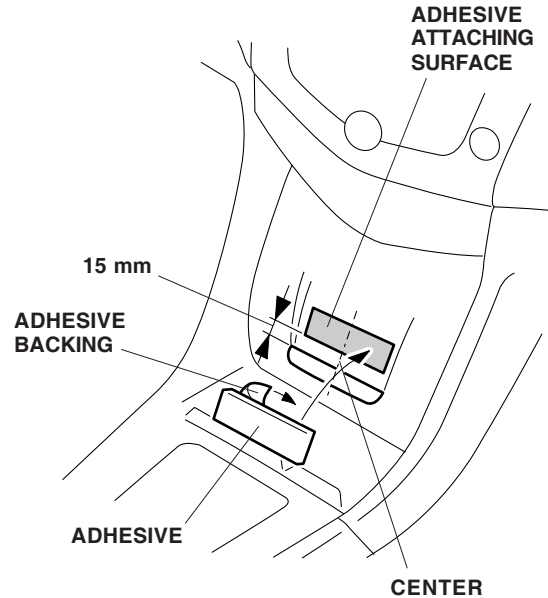

4. Remove and discard the adhesive backing from the adhesive, then attach the adhesive to the center pocket lid as shown.
5. Attach a strip of masking tape to the end of each outer adhesive backing, and pull back 40 to 50 mm of the adhesive backing. Fold the ends back, and tape them to the front of the center pocket trim. Remove and discard the inner adhesive backings.

### OUTER ADHESIVE BACKINGS (5)

Pull back 40 to 50 mm from the end, and tape to the front of the trim.

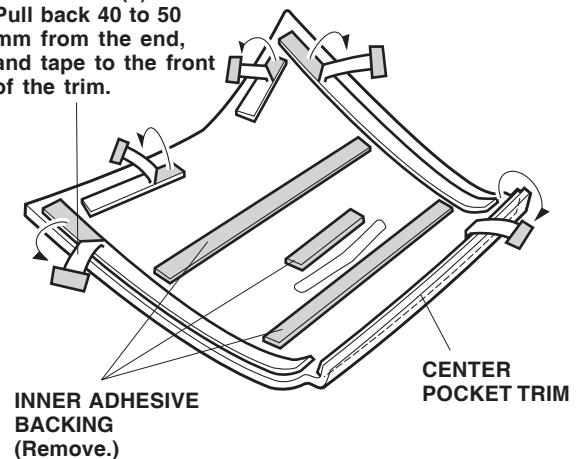

- Using isopropyl alcohol on a shop towel, thoroughly clean the area where the center pocket trim will attach.

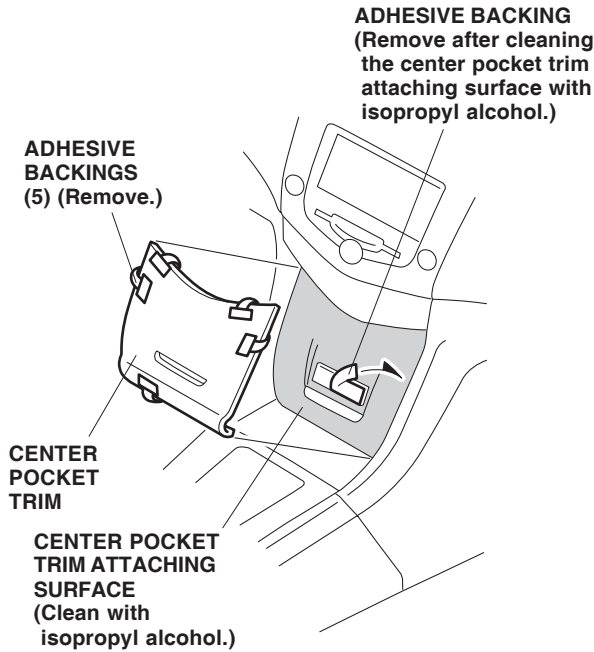

- If applicable, remove the adhesive backing from the adhesive strip.
- Position the center pocket trim on the center pocket lid. While applying light pressure on the trim, carefully remove the adhesive backings.
- After installing the center pocket trim, use the palm of your hand to hold pressure against it for 30 seconds.

## Installing the Trim Ring Trim

- Using isopropyl alcohol on a shop towel, thoroughly clean the areas where the trim ring trim will attach.
- Attach a strip of masking tape to the end of each outer adhesive backing, and remove 40 to 50 mm of the adhesive backing. Fold the ends back, and tape them to the front of the trim ring trim.

### With Seat Heaters

**OUTER ADHESIVE BACKINGS (6)**  
Remove 40 to 50 mm from the end, and tape to the front of the trim.

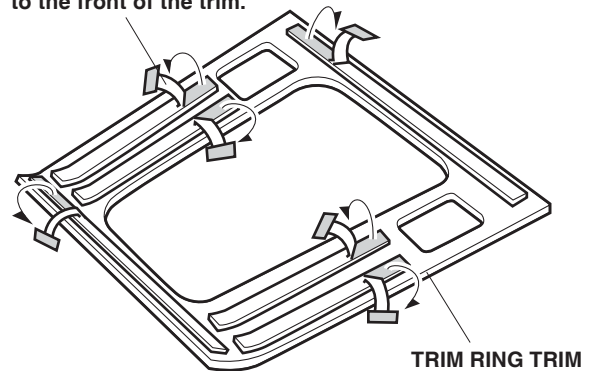

### Without Seat Heaters

**OUTER ADHESIVE BACKINGS (6)**  
Remove 40 to 50 mm from the end, and tape to the front of the trim.

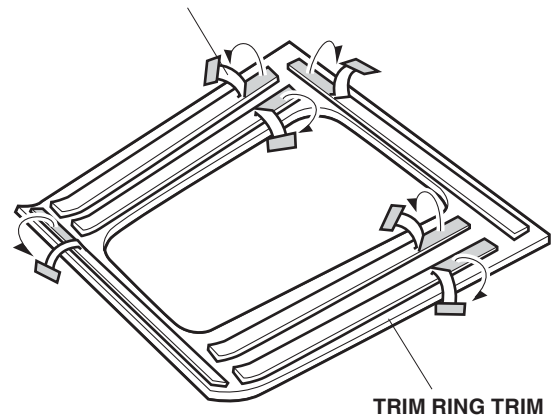

12. Position the trim on the existing trim. While applying light pressure on the trim, carefully remove the adhesive backings.
13. After installing the trim ring trim, use the palm of your hand to hold pressure against it for 30 seconds.

#### With Seat Heaters

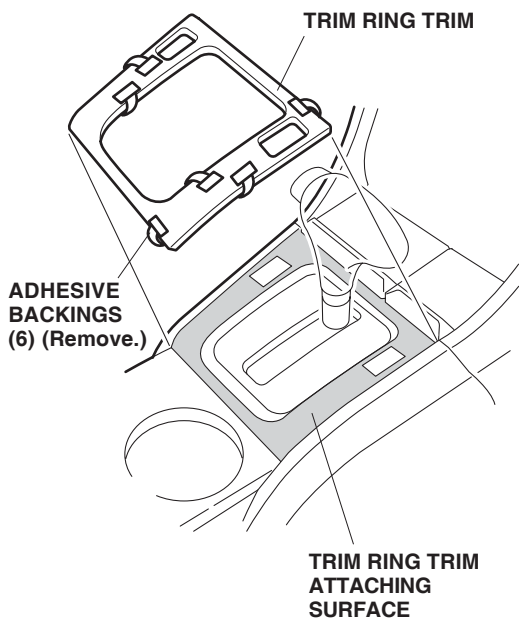

#### Without Seat Heaters

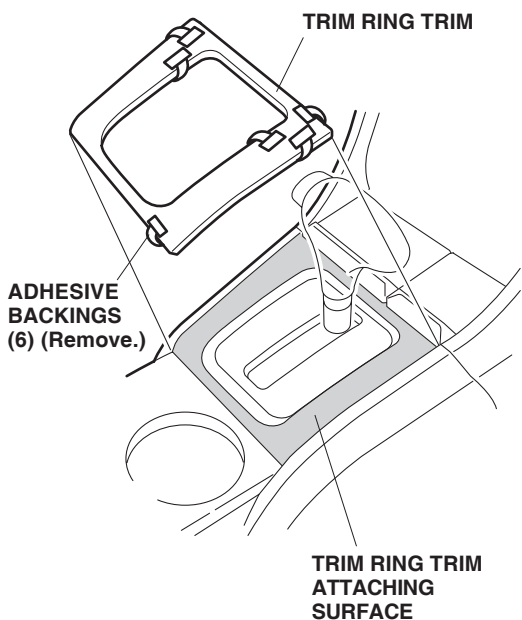

#### USE AND CARE

Use a sponge or soft cloth dampened with mild detergent and water solution. After cleaning, wipe with a clean, soft cloth. Do not use cleaners or polishers containing compounds to clean the center panel trim pieces as they may damage the surface.